

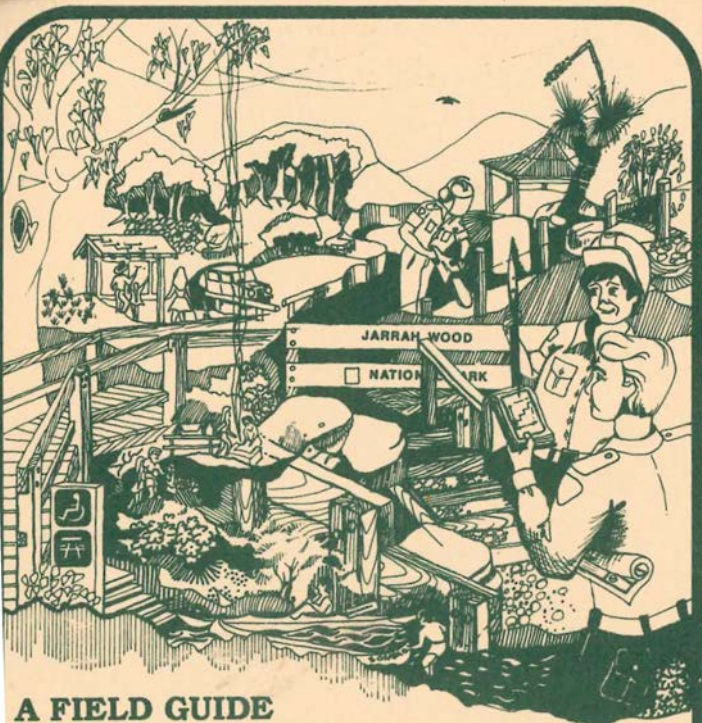

# LIBRARY

Department of Biodiversity,  
Conservation and Attractions

This PDF has been created for digital preservation. It may be used for research but is not suitable for other purposes. It may be superseded by a more current version or just be out-of-date and have no relevance to current situations.



**A FIELD GUIDE  
RECREATION FACILITIES  
CONSTRUCTION STANDARDS**

 Department of Conservation and Land Management

## **GOING FORWARD !**

This pocket booklet has been prepared as a field reference. Each card contains specific standards and some handy construction tips.

Comprehensive planning guides and design details are provided in CALM's Recreation Operations Manual, Sign Manual and the Small Structures and Hardware Portfolio.

The pocket guide has been compiled using information collected from designers, construction crews, field staff, rangers and other technical publications. Alternative construction methods are constantly being developed in the field. New ideas for this booklet can be sent to Recreation and Landscape Branch, CALM, Hayman Road, Como.

**BE CREATIVE - HAVE FUN !**

# CONTENTS

<b>SEATS.....</b>	<b>A</b>
<b>TABLES.....</b>	<b>B</b>
<b>BARBECUES.....</b>	<b>C</b>
<b>FENCES AND GATES.....</b>	<b>D</b>
<b>BOLLARDS AND BARRIERS.....</b>	<b>E</b>
<b>STEPS.....</b>	<b>F</b>
<b>BRIDGES AND DECKS.....</b>	<b>G</b>
<b>PARKING.....</b>	<b>H</b>
<b>ROADING.....</b>	<b>I</b>
<b>RETAINING WALLS.....</b>	<b>J</b>
<b>RUBBISH DISPOSAL.....</b>	<b>K</b>
<b>SHELTERS.....</b>	<b>L</b>
<b>FASTENERS.....</b>	<b>M</b>
<b>EARTH SHAPING AND DRAINAGE.....</b>	<b>N</b>
<b>ACCESS FOR DISABLED.....</b>	<b>P</b>

# SEATING

A1

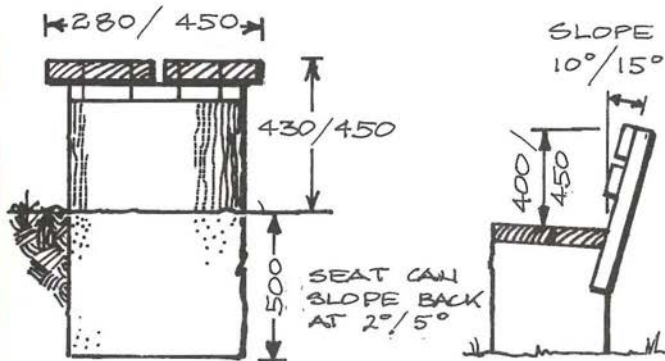

## BACK REST

Use back rest where senior citizens are expected or long stays anticipated.

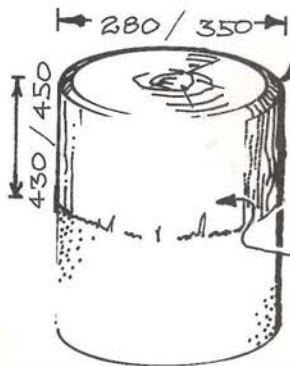

Remove bark prior to putting into ground. Treat in ground section against termites.

## TIPS FOR LOCATION OF SEATS ALONG TRAILS

A2

- Place seats/benches at the top of steep sections.
- For summer use, place seats in shade.
- Locate seats to take advantage of good views.
- Avoid locating seats in spots where users will overlook other recreation sites.
- When siting seats in forest areas look up to see what may come down.
- It's generally an advantage to have some seats in fixed locations and others moveable.
- Where possible locate bench/seat so that users do not look over the path.



## SEATING

A3

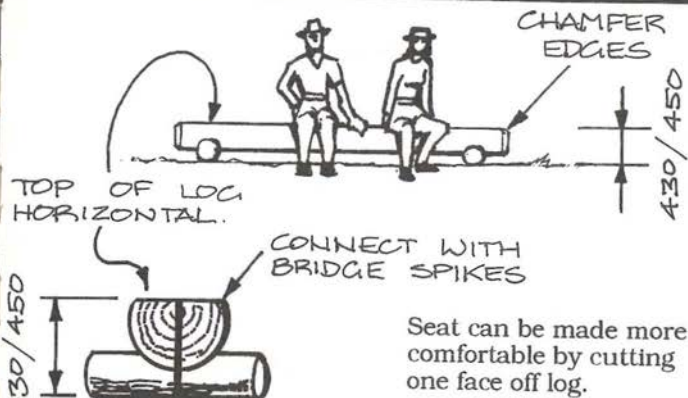

Seat can be made more comfortable by cutting one face off log.

BENCH SEATING - allow 600 mm per person  
(typical seat - 1800 mm long).

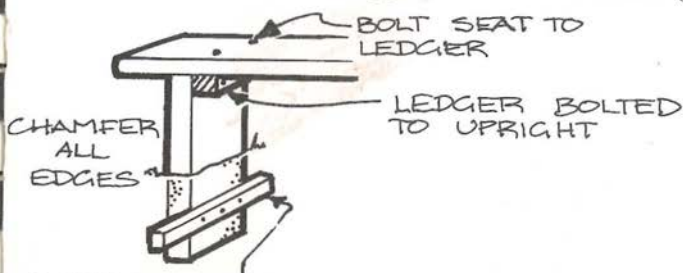

Bolt 'T' piece to give extra support and to minimise chance of removal. Also possible to set into concrete.

## TIPS FOR SEAT CONSTRUCTION

A4

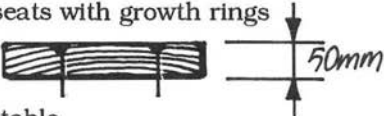
- Construct timber seats with growth rings up (back sawn). A diagram showing a cross-section of a timber board with growth rings. To the right, a vertical dimension line indicates a thickness of 50mm.
- Ensure seats are stable.
- Don't paint timber.
- Chamfer all edges and remove splinters.
- Allow 1% forward cross fall toward rear of seats for drainage
- Treat with a 50/50 mixture of raw linseed oil and kerosene or a sealant such as "Bondcrete".
- Don't oil seats in busy periods as oil will stain clothes.
- Avoid nailing or screwing into end grain of timber.
- Countersink all bolts except cup heads. Set nut on inside of structure and cup head on face side.
- If using 'Tek' screws select self countersinking types and drill a pilot hole.
- Treat all in-ground timber with white ant repellent.

## SEATING

A5

Guide for sawn timber size-to-length ratio for seats.

Board	Span	Seat Length
38 mm	900 mm	1200 mm
50 mm	1200 mm	1800 mm
75 mm	1800 mm	2400 mm

An alternative is to use 75 x 50 mm boards on edge to make batten type seating.

Allow 600 mm length of bench per person.

## TABLES

B1

Table widths: 750-900 mm

Table lengths: 1800-2200 mm

Table heights: 730-800 mm

Wheelchair accessible table height: 750 mm wheelchair clear under table.



In high-use areas and for wheelchair-accessible tables, the ground surface under the table and in the wheelchair mobility area needs to be sealed/hardened.

## TIPS FOR TABLE CONSTRUCTION

B2

- Where possible build table in workshop and install on site.
- Have rough sawn timber planed at the mill, it saves much time with little added cost.
- Treat all in-ground timber with white ant repellent.
- If using 'green' timber butt all planks on table top. Shrinkage will create spaces.
- Chamfer all external edges - including bottom side of the edges of seat and table.
- Self-tapping 'Tek' screws can be used for fixing table top and seating. Pre drill holes for 'Tek' screws as timber is likely to split.
- Countersink all bolts.
- Treat timber with a 50/50 mixture of raw linseed oil and kerosene or a sealant such as 'Bondcrete'. Don't oil in busy season as oil stains clothes. Never use paint.
- Retighten bolts after first summer or as timber shrinks.

## TABLES

B3

### TABLE/SEAT COMBINATION

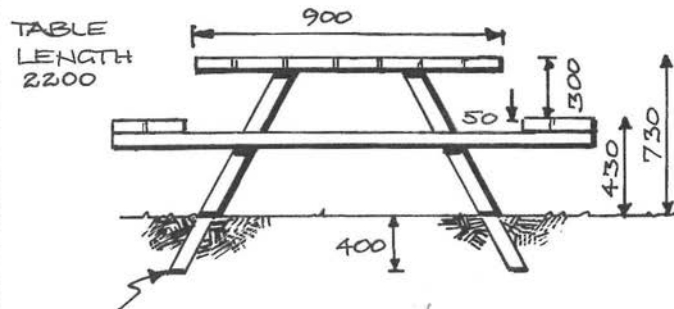

TABLE LEGS CAN BE MADE 400 LONGER AND DUG INTO THE GROUND.

- The portable version of this table can be used in situations where visitors seek summer shade and winter sun.
- This table is stable without legs dug into ground.

See design in CALM Recreation Operations Manual.

## TIPS FOR SITING TABLES

B4

- Grade table site to 1:40.
- The levelled area should extend at least 2 m beyond the table.
- Place on upwind side of barbecue, consider prevailing wind during peak use period.
- Orientate table so that visitors don't have their back to the view.
- Tables should be set level. Use a spirit level when siting tables.
- Be consistant. Use only one table style in a recreation area.

## TABLES

B5

### TABLE/SEAT COMBINATION

Not accessible for wheelchairs.

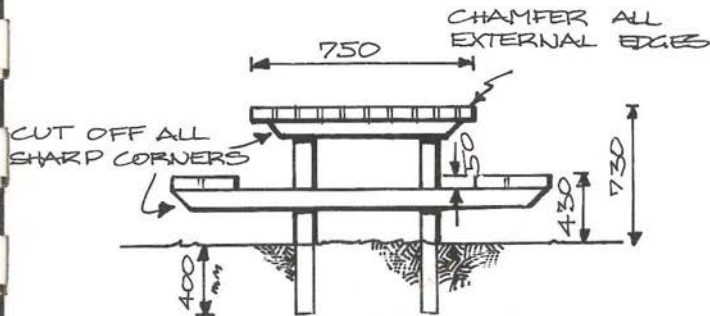

Place post at least 400 mm in ground. In theft risk areas add 'T' piece and concrete around posts.

See Designs in CALM Recreation Operations Manual.

- This table style is generally used in permanent locations. The stability comes from the uprights being placed in the ground.
- To get table level chock under the seats and then compact soil around uprights.

## METAL FRAME - TIMBER SEAT AND TOP

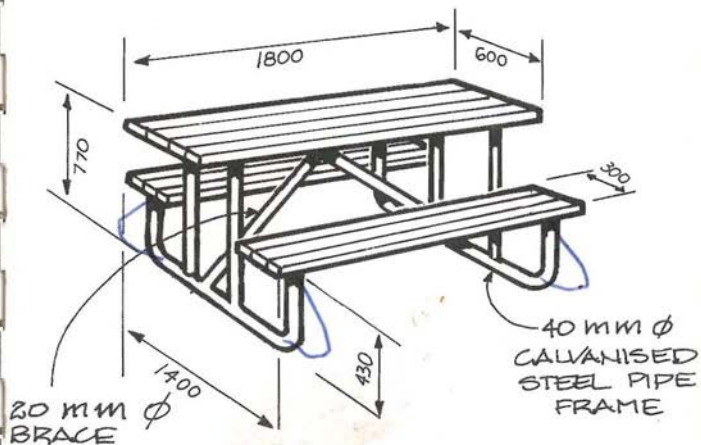

- This design allows easy access to the table. Visitors do not need to step over seat.
- One end of the table could be extended for disabled visitors.

- Secure table to ground by use of concrete footing or by concreting a hard surfaced area around table. If not anchored table can tip if two or more people site on one side only.

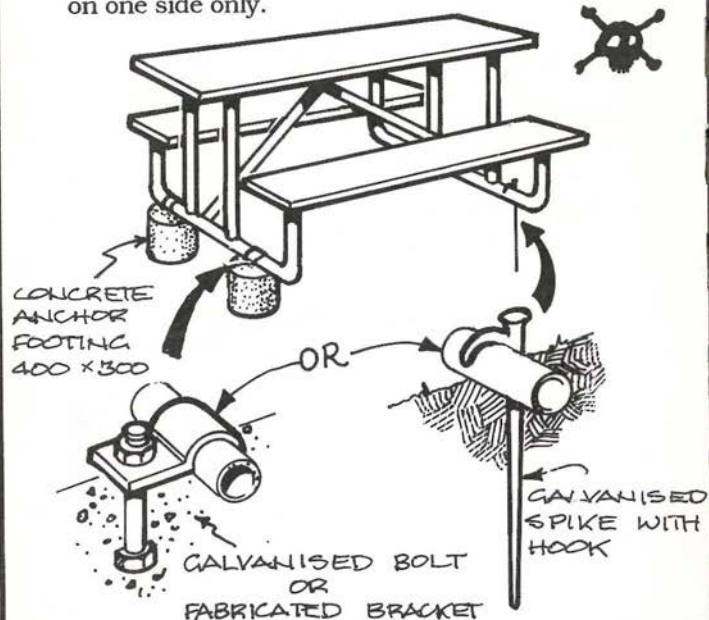

## TABLE/SEAT COMBINATION

Modification to standard table design to accommodate wheelchairs.

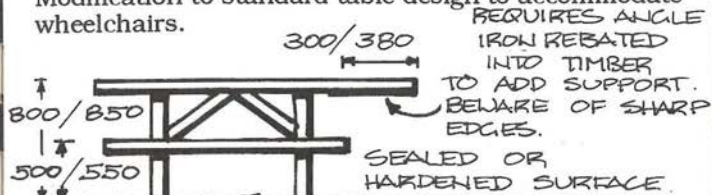

Extend one or both ends of the table 380 mm beyond standard T2/T3 designs.

See CALM Recreation Operations Manual.

The height will vary for different wheelchairs: standard wheelchair - 750 mm; electric wheelchair - 850 mm.

**NOTE:** Seats are higher than standard on disabled accessible tables.



This style of table offers easy access to seats as there is no need to step over seat.

- Ensure that disabled visitors have access from the car park to the picnic area and toilets.
- Place disabled accessible table with good views to feature or activity areas.
- Make barbecues and bins accessible for disabled visitors at sites where total access is planned.

Slope plate slightly to the back so that fat and oils drip into the fire place.

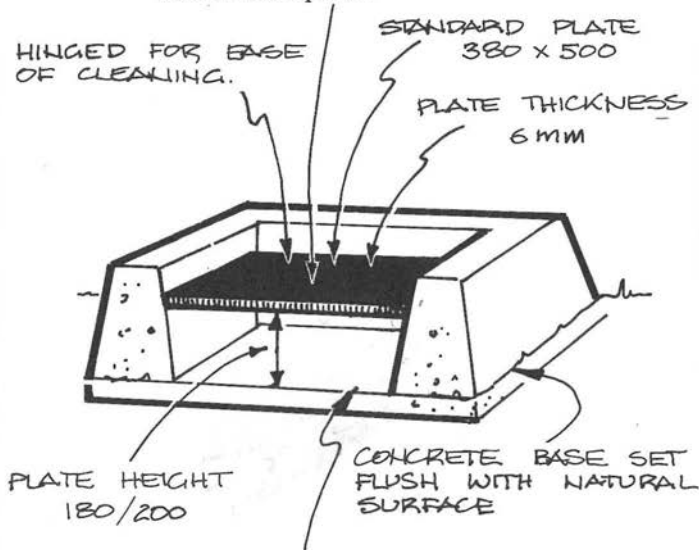

Slope base slightly forward to ensure adequate drainage.

## TIPS FOR BARBECUE CONSTRUCTION

C2

- Don't fix steel directly to concrete as steel expands when heated and will crack concrete.
- There are two options for placing the plate-support pipes into the barbecue.
  1. Cast the hole large enough to cater for the expanded metal.
  2. Wrap cardboard around the pipe ends - when heated this burns off leaving a space for expansion.
- Pivoting plates make barbecues much easier to clean and maintain and less prone to damage if visitors build a large 'campfire' in the barbecue.
- Tint concrete to blend with local soil (optional).

## BARBECUES

C3

### TWO SIZES

Group fire ring: 1280 width.  
Single fire ring: 850 width.

Set into ground so that  
plate is 180/200 mm  
above surface.

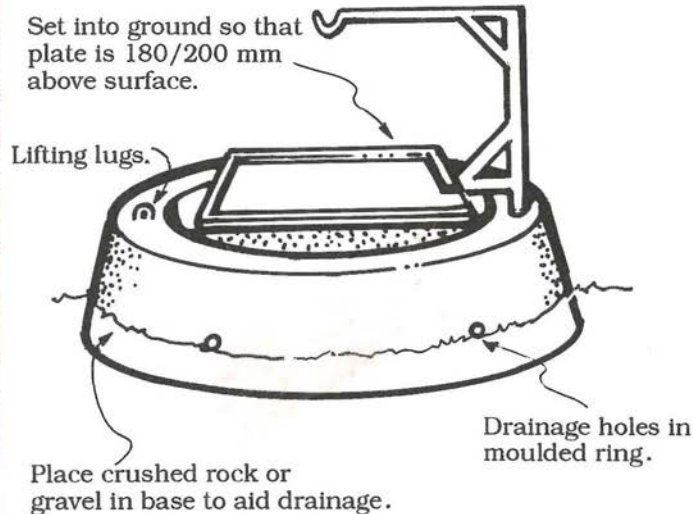

## TIPS FOR SITING BARBECUES

C4

- Locate barbecue downwind from picnic table.
  - In forest areas avoid placing barbecues where overhead dangers are present.
- 
- Locate barbecues centrally if they are to serve two or more picnic nodes.
  - If the barbecue is closer to one table than the other visitors tend not to share it.
  - When siting the round barbecues avoid having the swinging plate in the main pedestrian movement area and paths.
  - Do not locate barbecues in a depression.
  - Provide a 3 m wide cleared section around barbecues in fire risk areas.

## SINGLE GAS BARBECUE

C5

Barbecue can be housed in a variety of materials. Selection should be based on site suitability. Common materials include cut stone, bush rock, brick and wire mesh.

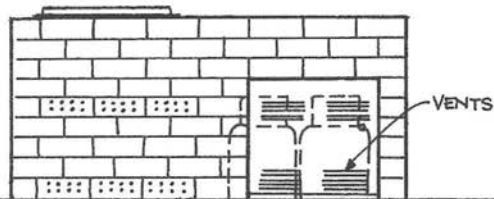

- SECTION - REAR VIEW

Dimensions: 910 mm high, 835 mm wide, 1795 mm long, 3000 x 2200 mm base.

- Pot boilers are generally required, as hot plates are inefficient for boiling water.
- Double units can be built in high use areas.
- Ensure that plate has 10 mm clearance from brickwork to allow for expansion.

## TIPS FOR BARBECUE CONSTRUCTION

C6

- **Ventilation:**  
Barbecue enclosure must have a minimum of 2400 sq mm including upper and lower ventilation to provide sufficient air for combustion. Bottom vent must be no more than 100 mm above ground level.
- A separate gas supply enclosure is recommended.
- Cylinder enclosure must have a minimum of 2000 sq mm including upper and lower ventilation, and must be drained from its lowest point.
- A separate brick enclosure, as shown, is required for cylinders if they are to be stored within the barbecue enclosure.
- Cylinder enclosure door must have a minimum of 4000 sq mm of ventilation.
- Cylinders shall be installed such that any discharge from the relief valves is directed towards the vented door.
- Concrete base should slope away from the barbecue and should have a broomed finish.
- Ensure adequate ventilation for unburnt gas.



## HOT PLATE AND BURNER ASSEMBLY

C7

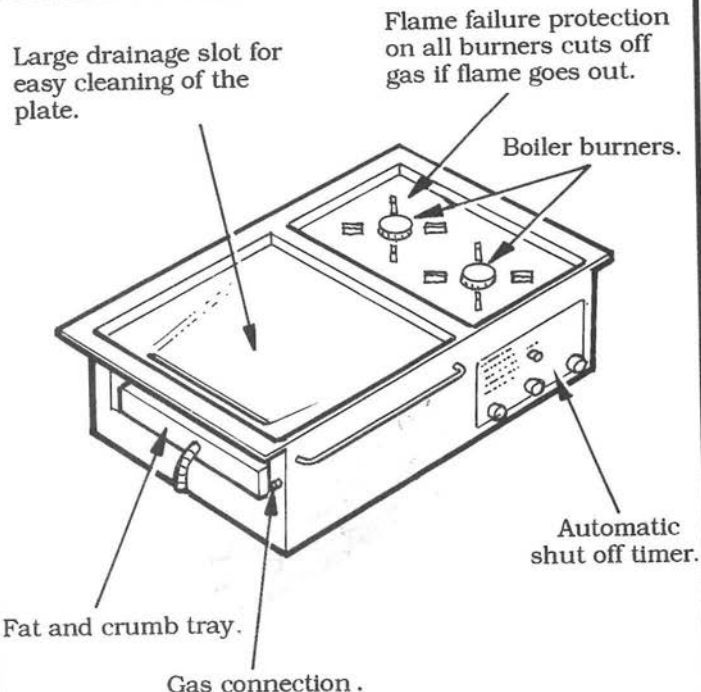

## GAS BARBECUE

C8

Wire mesh cage contains gas bottles and supports barbecue assembly.

Full hot plate or hot plate and boiler assembly.

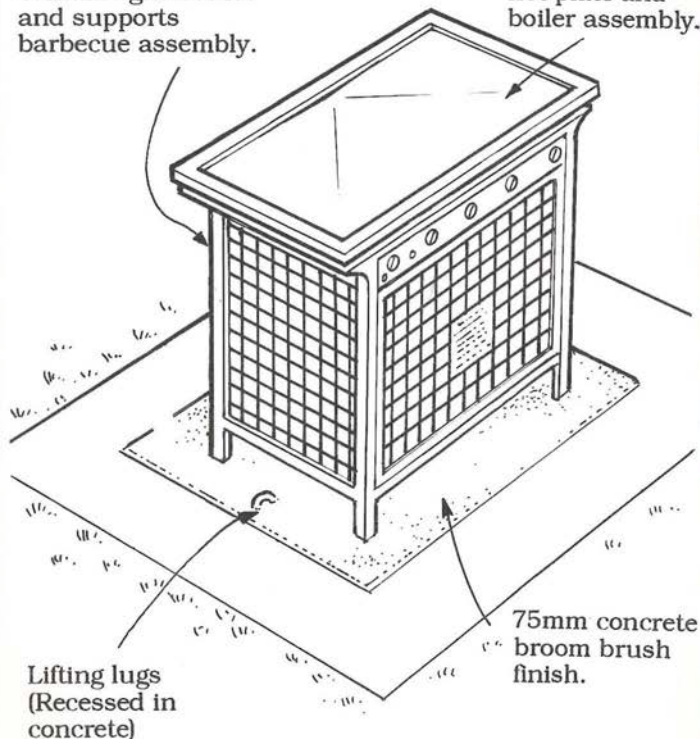

75mm concrete broom brush finish.

Lifting lugs (Recessed in concrete)

## FENCING

D1

### STRAINER ASSEMBLY

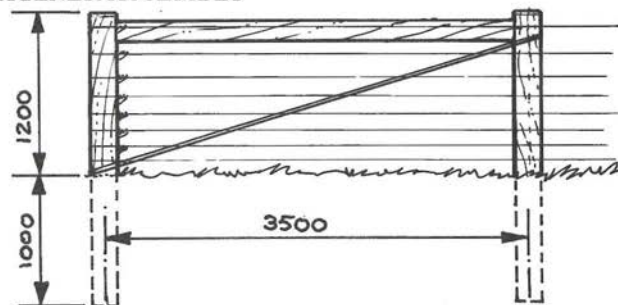

### STRAINER POST AND STAY

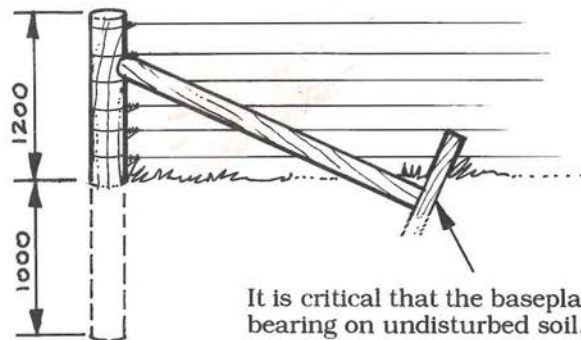

It is critical that the baseplate is bearing on undisturbed soil.

- When planning a fence alignment minimise the number of corners.
- Always set posts on high points of rises and low points in the landscape.
- Always have posts vertical - strainer posts may be set 5 degrees back from the fence line. The straining of the wires will pull them back to vertical.
- Firmly ram backfill around posts with hammer-head crowbar. Stabilise with concrete where needed.
- Use auger to dig holes where practicable to keep the hole diameter to a minimum.
- Space posts in recreation area 3000-5000 mm apart.
- Numbers of strands and types of wire will vary with the purpose of the fence.

## CORNER ASSEMBLY

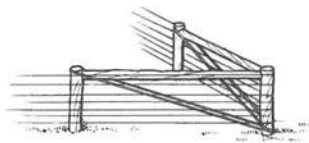

Use corner assembly for bends less than 120 degrees.

Construct the strainer assembly so that the stay bisects the angle of the corner, or have two separate end posts at the corner for each fence.

## BEND POST WITH STAY

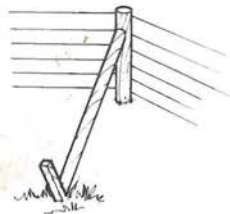

## BEND ASSEMBLY

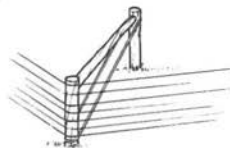

- Use two complete rounds of 2.8 mm high tensile wire for the diagonal guys for corner and bend strainer assemblies

It is best to strain and tie off the guy rather than twist tighten it. Use the loop, crimp and pin knot to tie off guy wire.

- Strain the bottom wire of fence first. Straining the top wire first will pull the post over.
- If using plastic coated wire or wire netting avoid green. The black plastic is less obtrusive. White may be used where either safety or good visibility are issues.



- Never use a single strand of wire as a fence, gate or barrier.
- Never use barbed wire in recreation areas.

## KNOTS

## FIGURE OF EIGHT KNOT



## LOOP, CRIMP AND PIN KNOT

Loop wire end

Locking pin



Crimp wire end



## STRAINER KNOT

Tie end off neatly to avoid risk of wounding visitors.

- In recreation areas chamfer top of posts.
- Ensure that wire joints are finished off so that visitors will not be scratched or cut.
- Bolt head, screws and fasteners should not protrude from the timber.
- Avoid using sledge hammer to ram in star pickets. The hammering can result in dangerous edges at the top of the picket. Use proper post rammer as it is safer and much easier.

STEEL  
POST  
RAMMER

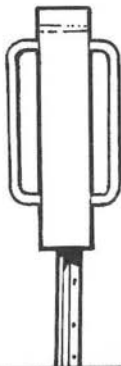

## MANAGEMENT ACCESS ONLY GATES

SWING GATE  
FROM UP-HILL POST

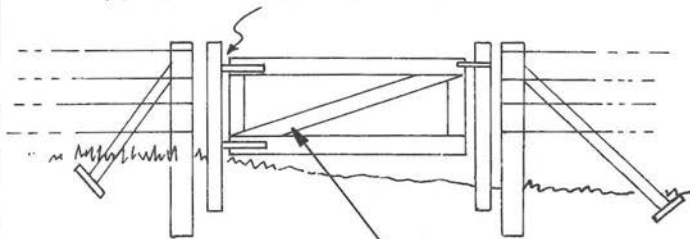

CROSS BRACE SLOPES DOWN  
AND IS SUPPORTED AT THE  
HINGED END

Note : There are numerous metal and timber gate designs available. Choose one to suit the purpose and the landscape.

- When locking a gate ensure the key is common to all management personnel.
- Design gate so that weight is supported when in closed or open positions.
- Strainer posts supporting gates must be well braced or the tension of the fence will pull the posts apart and the gate will be difficult to close.
- In soft soil such as sandy loam, separate gate posts may be put in beside the fence strainer post.

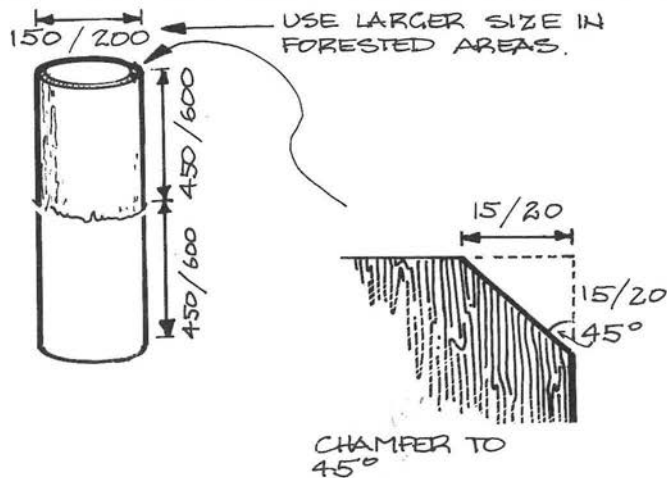
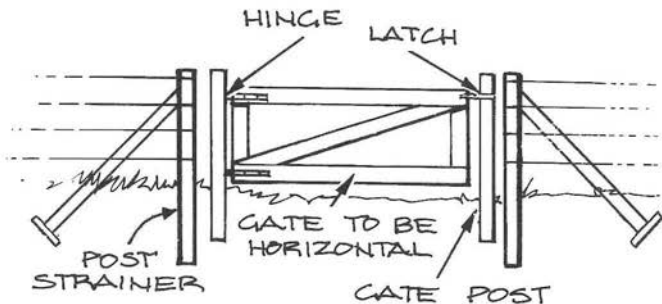

- Seal top of bollard with 'Bondcrete' to minimise splitting, or treat with 50/50 mixture of raw linseed oil and turps.
- Treat in ground section with termite repellent.
- Use same spacing throughout recreation area.

- Use 600 mm high bollards to identify pedestrian paths and places where cars are reversing. Generally use taller bollards in forest areas and shorter bollards in arid or coastal landscapes.
- When using the shorter bollards use the thicker size.
- When using treated pine poles select a bollard length that can be cut with no waste from standard lengths, for example, 900 mm bollards from 1800 or 2700 mm poles.
- Place bollards deeper in ground where bollards are prone to being removed. Alternatively add 'T' piece to bollard as shown in Figure E8.
- Use centre to centre spacing when setting out bollards. Ensure spacing meets user requirements particularly access for disabled visitors.
- Be certain that bollards are vertical and the tops are horizontal. Use a spirit level.
- If using hardwood bollards select poles in winter or spring as they are easier to debark in these seasons.

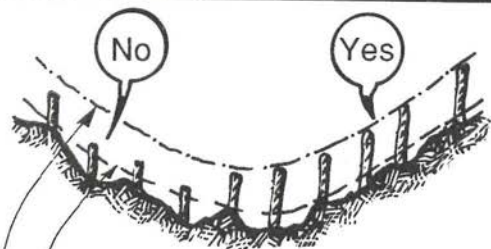

General profile of land (avoid following micro undulations).

Constant height adjusted to general profile line.

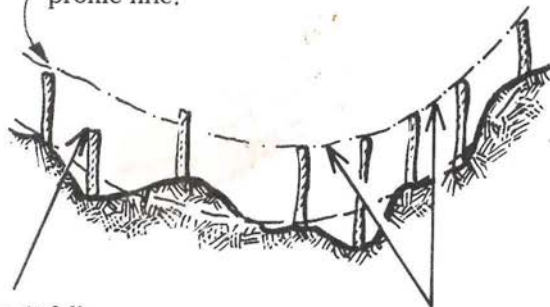

Don't follow micro variations of terrain

Follow an even height profile

## TIPS FOR LEVELLING BOLLARDS

E4

- Measure standard height after putting in ground.
- Prior to cutting, "eye in" minor level changes.
- Even out the top height profile by compensating for the sudden level changes such as humps and hollows.
- This may mean that some bollards in hollows are taller while others on mounds may be shorter - but the change would not be noticed by the visitor. The top line would appear even and gently curving in harmony with the general landform.
- Chamfer bollards once cut to final height.
- Cutting bollard tops to horizontal needs care and skill.

## TUBE NUT ASSEMBLY

E5

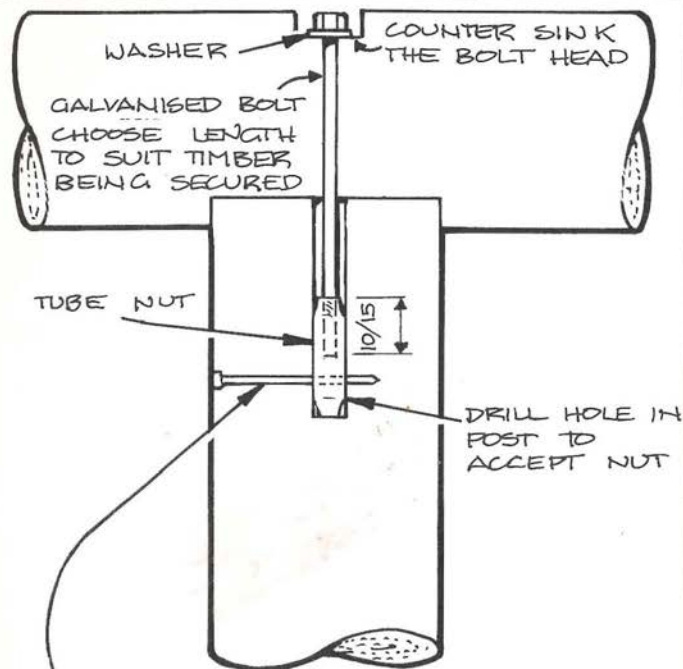

Secure tube-nut by nailing or spiking. Ensure that the fixing passes through the nut and is embedded at least 20 mm on the other side. Drill hole for nail after tube-nut has been placed.

# POST AND RAIL DETAIL

E6

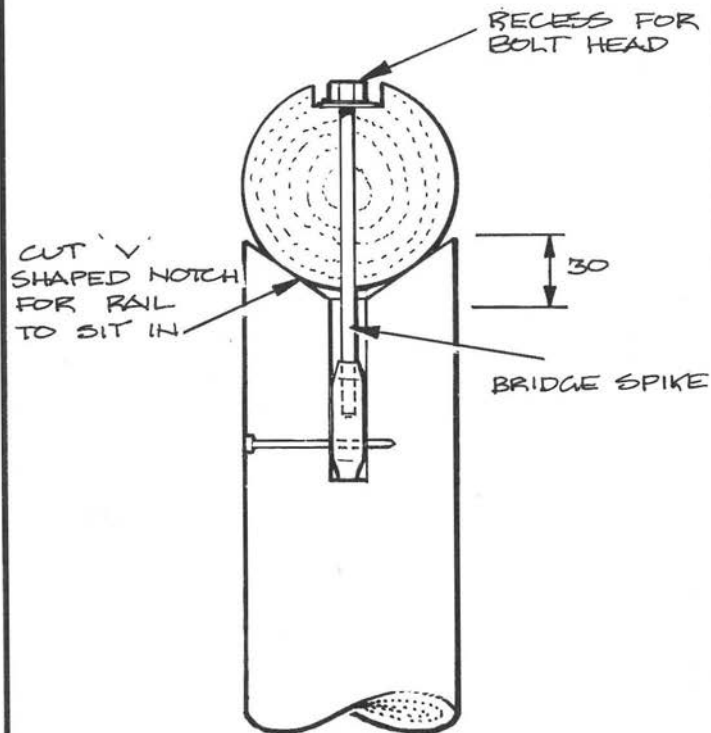

# VEHICLE BARRIER

E7

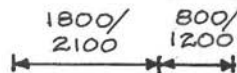
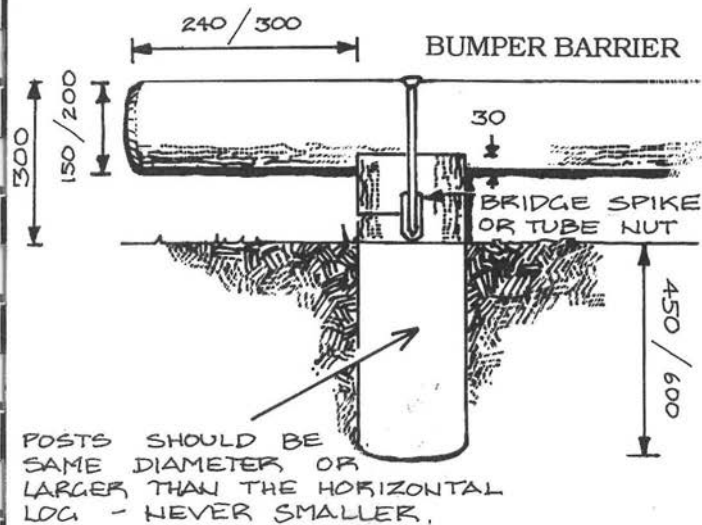

Vehicle bumper barrier height should connect with bumper - not to be confused with wheel stop barrier.

- Vehicle barriers and bollards are sometimes removed by vandals. Removal can be made more difficult by one of the methods below.

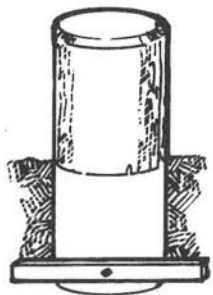

- Bolt or nail piece of wood to base of post.
- Drill hole through post and put in section of galvanised pipe.
- In extreme circumstances drill hole through posts and link with discarded winching cable or galvanised chain.

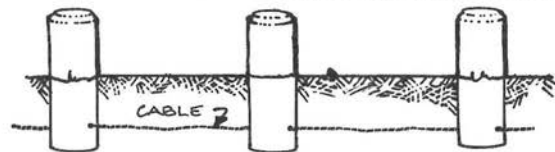

NEVER PLACE BOLTS OR SPIKES DOWN LENGTH OF BOLLARD - EXTREMELY DANGEROUS IF POST IS CUT WITH CHAINSAW.

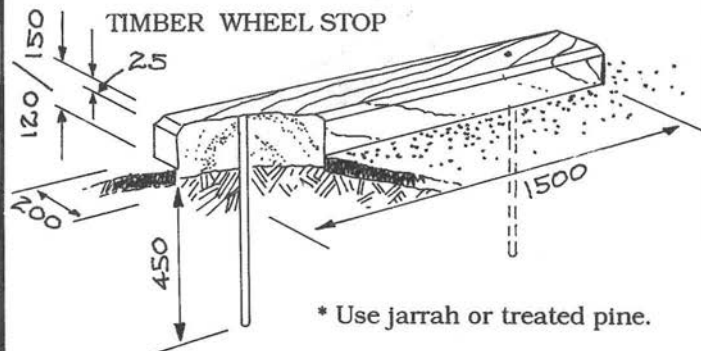
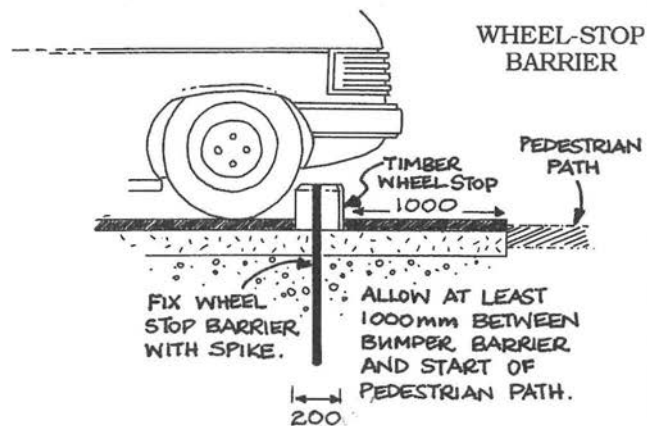

TIPS FOR  
BARRIER CONSTRUCTION

E10

- Wheel-stop barriers tend to concentrate runoff water.
- Wheel-stop barriers are easily crossed by four wheel drive vehicles.

BARRIERS

E11

When making rock barriers use local stone. Minimise machine damage to rocks.

- Place rocks 1/4 to 1/3 into the ground. It is generally better to have widest section in ground. The barrier becomes far more effective and looks more natural.
- Avoid regular spacing and regular rock size.



Poor positioning.



Good positioning.

- It is not easy to construct rock barriers which appear natural. Specialist assistance may be required.
- Link to existing rock outcrops where possible.
- Look at the natural rocks in the area and try to create the same effect when repositioning boulders.
- Avoid straight lines and even spacing.
- Avoid using all rocks of the same size.

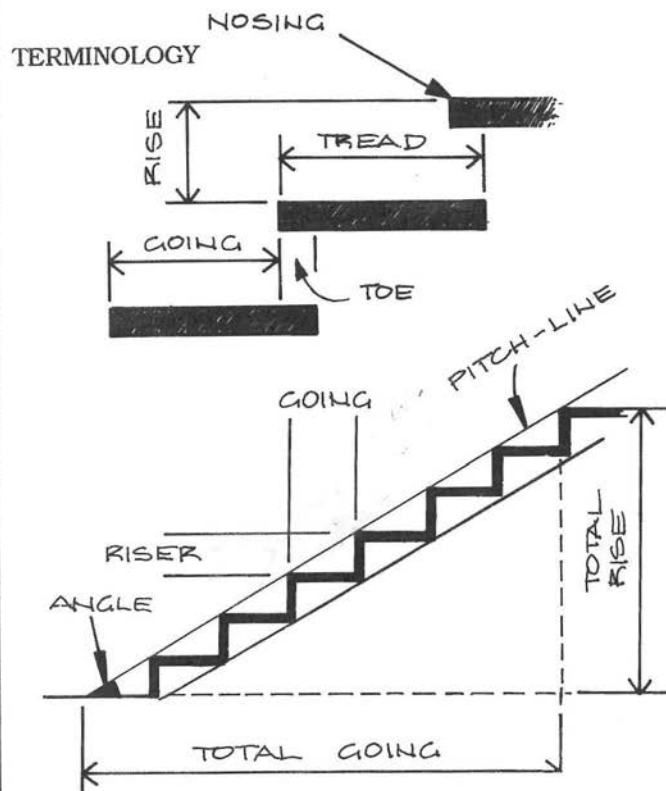

## STEPS

F2

Step must conform to set standards. Riser/tread ratio should probably comply with the formulae below:

- a)  $2 \times \text{riser} + \text{tread} \approx 600 \text{ mm}$
- b)  $\text{Riser} + \text{tread} \approx 460 \text{ mm}$

### Example

Riser = 165 and Tread = 300

- a)  $2 \times 165 + 300 = 630$
- b)  $165 + 300 = 465$

Boxing of riser

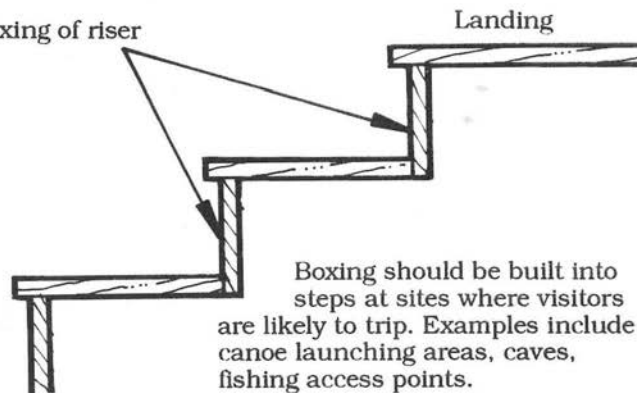

Boxing should be built into steps at sites where visitors are likely to trip. Examples include canoe launching areas, caves, fishing access points.

## STEPNOLOGY

F3



Never leave gap between treads.

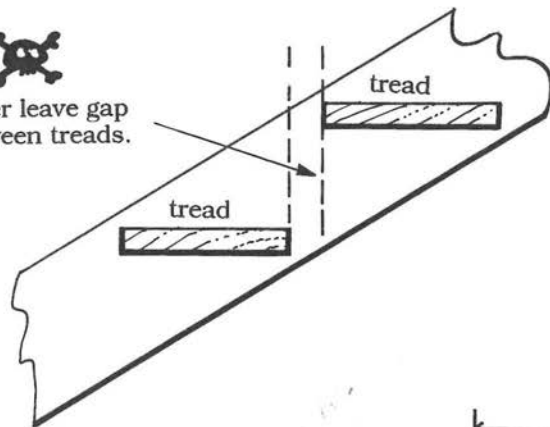

Landings should be at least 900 mm wide or equal to the width of stairway.

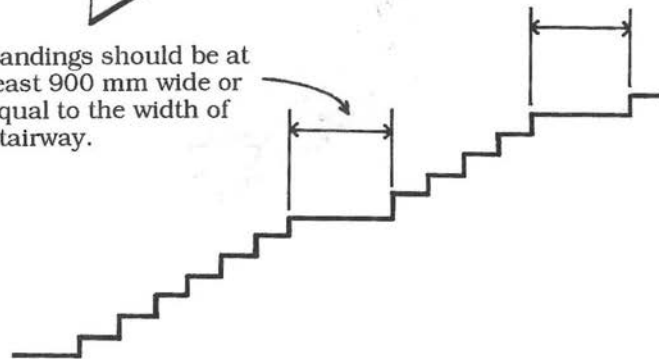

## TIPS FOR STEP CONSTRUCTION

F4

- Avoid a single step. Build at least two or three steps as the level change is more easily seen and therefore visitors are less likely to trip.
- Don't start or finish or interrupt an otherwise continuous ramp with a small flight of steps.
- Where practicable, ramps should be built to provide access for disabled visitors.
- Combination of ramp and steps may be used where slopes are variable. Ramp section should be made long enough for three paces so that alternate legs can be used when negotiating steps.
- Be sure handrail structure extends at least 300mm beyond end of steps and ramps.
- Avoid flights of steps with more than 13 risers.

## STEPNOLOGY

F5

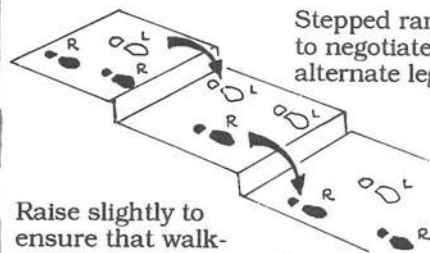

Stepped ramp should allow user to negotiate the risers with alternate legs.

Raise slightly to ensure that walk-trail does not become the flowline. Regrade to ensure that the step does not form a trip line.

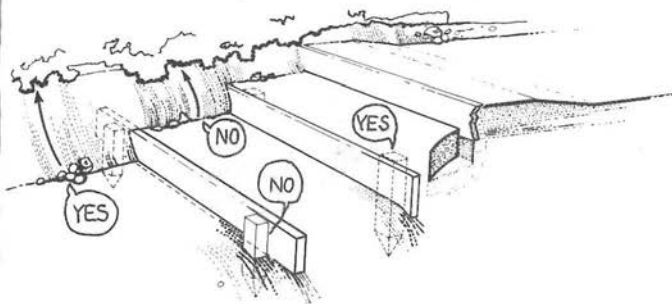

Post in front - poor detail but can be used where riser extends beyond trail width and the support post is buried.

## HAND RAIL DETAILS

F6

POOR PRACTICE  
END GRAIN  
EXPOSED

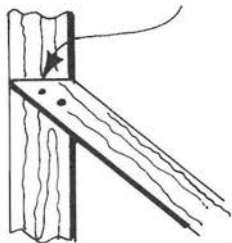

GOOD PRACTICE  
END GRAIN PROTECTED.

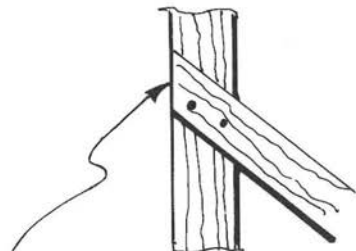

Use single fastener on round poles.

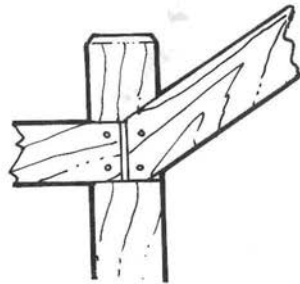
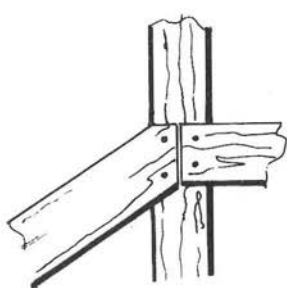

This joint design can be easily cut for rebating.

## STEP PLANNING

F7

1. Measure total rise (for example 1820).
  2. Determine appropriate step riser height - 165.
  3. Divide total rise by step rise  $1820 \div 165 = 11.03 =$  say 11 risers.
  4. Determine tread width to meet standard formula - 300 mm.
  5. Calculate total going  $300 \times$  number of treads.
- \* Remember number of tread = risers + 1  
(include the tread at the base of the first riser.)

This example  $11 + 1 = 12$   
 $12 \times 300 = 3600$

6. Plot top and bottom of flight of steps. Where space is limited tread distance may be adjusted within the standard formula, for example, by reducing the tread size from 300 down to 290 will save 120mm on a flight of 12 steps.

## STEP PLANNING

F8

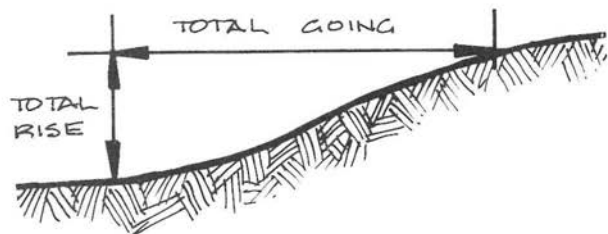

- Once a step ratio has been selected use it throughout the recreation area.

## STEPS AND RAMPS

F9

- Ramps accommodate wheeled traffic and provide access for disabled visitors. They are often cheaper than steps but require at least six times more space.
- Ramps should not be steeper than 1:15 and should not be more than 9 m in length without a rest area when at a slope of 1:15.

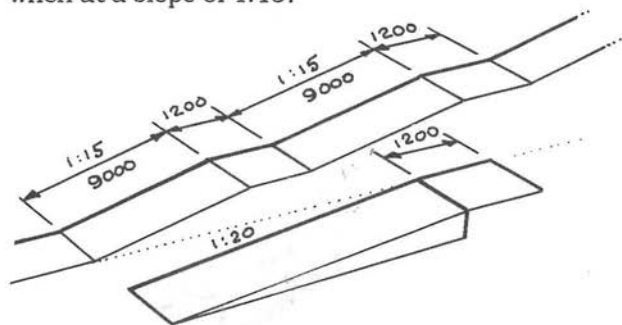

The 1:20 gradient trail should have a 1200 mm long level rest area should be located at the top and bottom of ramps or at intervals of 20 m or less.

- Handrails should be placed on ramps of 1:15 in heavily used sites - particularly those providing access for disabled visitors.

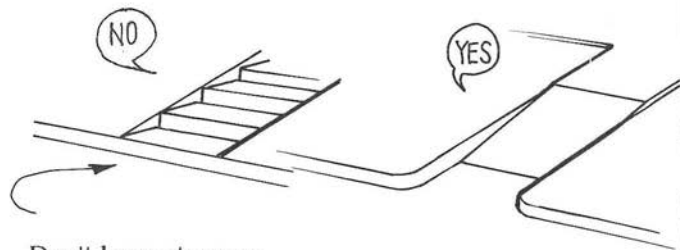

Don't have steps or ramp starting hard against intersections.

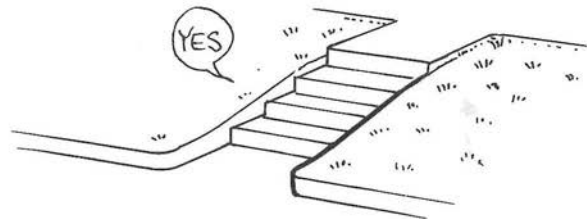

- Ensure that the top step/ramp is slightly above ground surface so the stairway does not become a drainage line. Be careful not to create a trip line.

- The upslope post on landings needs to be longer than the downside post to allow for the handrail angle.

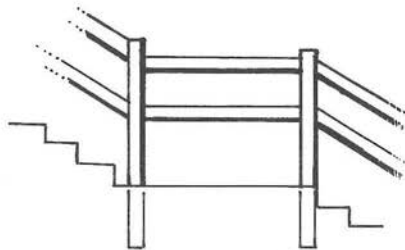

- Once a handrail height has been selected use it throughout the site.

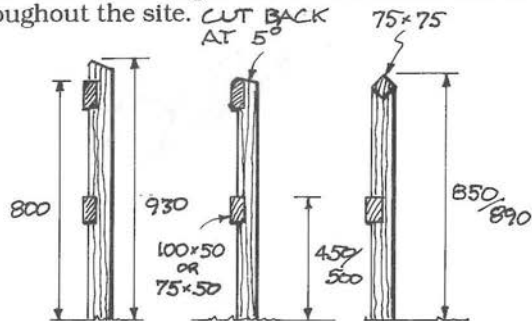

HANDRAIL OPTIONS

- When designing stairways, decking or bridges around a natural feature, ensure that the structure does not dominate the feature.

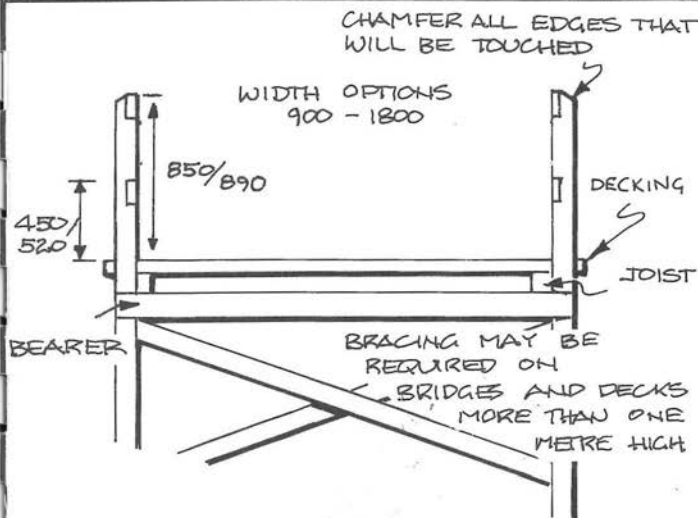

- Beware that small cars may use 1800 mm wide deck.
- Bridge, decks and boardwalks often become a focus for visitors and a place for rest or contemplation. Site works and work quality needs to be of highest standard due to the extended observer time at these features.

## TIPS FOR BRIDGE DESIGN AND CONSTRUCTION

G2

- Bridges should feel secure to the visitor.
- Bridge decks should be horizontal.
- Decking should be solid and securely fixed.
- Decking should be perpendicular to the bridge, not parallel.
- On low bridge only one handrail may be required - this should be on the down stream side.
- Avoid arched or hump-backed bridges.
- Ensure that end of bridges are flush with trail surface.
- Handrails should be securely fixed so they feel and look firm to the user.
- Ensure design of handrail fixing technique is completed prior to construction.
- Ramps leading to bridge should be 1:20 to allow for disabled access.
- Bridges for horses need to be very sound as horses are likely to shy at unstable structures.
- Bridge design over 2 m in length should be checked by a civil engineer.

## FOOT BRIDGES AND DECKS

G3

### KERBS OR GUIDE BOARDS

Use on low decks or bridges.  
COMMON SIZE 75 x 50

COMMON SPACE  
19 x 38

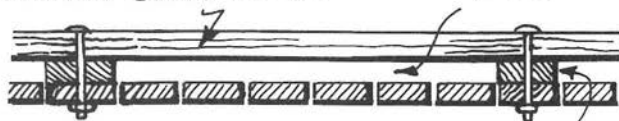

SPACERS SHOULD BE  
MADE FROM SAME  
WIDTH AS KERBING.

- Kerb can be built with or without spacers.
- Use spacers where leaf litter is likely to accumulate, this helps reduce fire risk.
- Ensure regular distance between spacers. Locate spacers to prevent kerb from warping or sagging.

SPACER  
19 x 38



CHAMFER CORNERS ON  
KERB. THE ADDITIONAL  
WORK RESULTS IN A  
SUPERB FINISH.

- When using green timber use hexagonal head bolts. Cup head bolts are difficult to retighten when the timber shrinks as the bolt tends to twist in the expanded hole.
- When designing the deck width consider the standard timber lengths - which generally come in increments of 300 mm.
- Timber is often cheaper in lengths of 2100 mm or less - considerable savings can be made by designing decks that can be made from 'shorts', for example, 2 x 1050 mm from 2100 mm.
- If making more than one bridge in a recreation area try to use the same design.
- Avoid long straight sections of boardwalks or decking.

HANDRAIL FIXING DETAILS

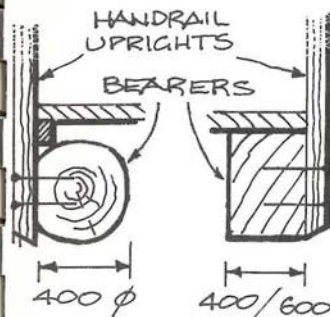

- Bridge spike or bolt handrail post directly to bearers.
- Drill holes for spikes in post - lead hole may be required in bearer.
- Use coach screws or bolts when building with treated pine.

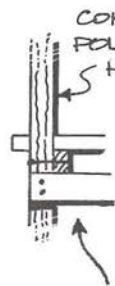

Preferred method.

CONTINUE SUPPORT POLE TO SERVE AS HANDRAIL UPRIGHT

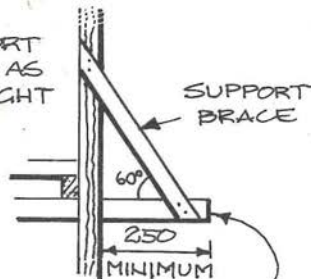

ENSURE BEARER WILL SUPPORT HANDRAIL

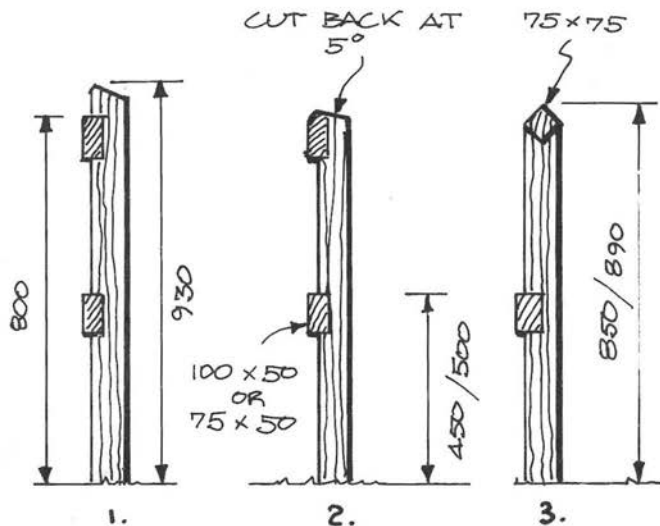

## HANDRAIL DESIGN OPTIONS

Three rails may be required in high-use areas and where facility is located over or near water.

## SWING BRIDGES

- Swing bridges can be used to cross deep gorges or flow lines where wheelchair access is not required.
- Design Features

Main cables need to be set at different heights. This allows upper cable to take some weight from the lower cable and decking.

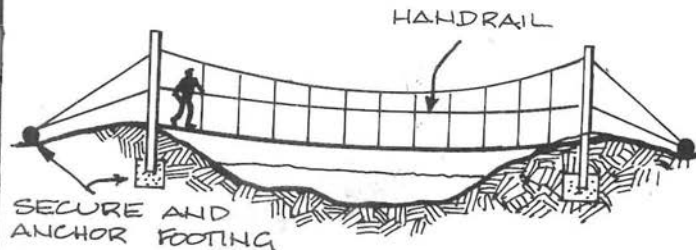

- Winching cable is flexible and very strong.
- Ends of bridges should be at equal elevation.



Bridge design must be checked by civil engineer.

## TIPS FOR SWING BRIDGE CONSTRUCTION

G8

- Make holes for cable 5 mm larger than the cable diameter. This allows easier winching up of the cables.
- Users will swing and bounce on bridge therefore stabilising wires may need to be set.
- A third lighter wire may need to be added to serve as a handrail.
- For ease of construction keep bottom cable 300 mm from ground level. Small ramps will need to be built at each end to allow easy access.
- Survey in levels as end heights are critical.

## PARKING

H1

### STANDARD DIMENSIONS

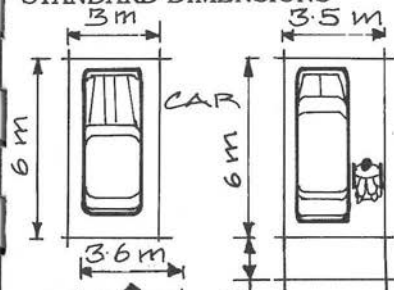

Mark parking bay for disabled with disabled symbol. Requires hardened surface.

The extra width allows wheelchair users to get in and out of car from the wheelchair.

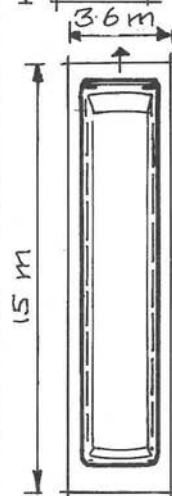

COACH

CAR WITH  
CARAVAN  
OR BOAT

Coach and caravan drivers prefer drive - through parking bays.



Backing in high use recreation areas can be dangerous.

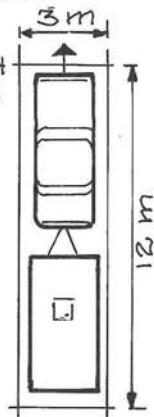

- Parking bays should be relatively level 1:15 to 1:40 is good. Drainage may be inadequate on slopes less than 1/40.
- Steep parking bays, particularly with laterite gravel surface, can be difficult to get out of due to lack of traction.
- Design parking perpendicular to roadway. 90 degree parking is easier to design, construct and is more space efficient than angle parking. Angle parking such as 60 degrees and 45 degrees is okay where width is limited but generally works best where bays can be clearly defined by line marking (usually on sealed surface).
- Where possible construct a pedestrian collector path in front of car park.

See design options in CALM Recreations Operations Manual.

## PEDESTRIAN MOVEMENT

Always allow for safe pedestrian movement in association with parking areas.

Pedestrians can move forward to collector path leading to facility.

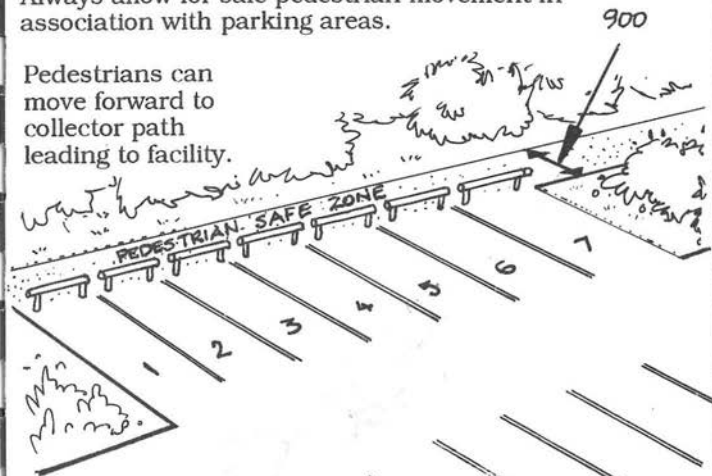

In natural setting avoid more than seven bays in a row without a vegetated barrier.

When screen planting use local vegetation species where possible.

- Direct runoff into vegetated areas.
- Use water harvesting techniques in low rainfall areas to assist with plant growth.
- Coach and van doors are on left-hand side (kerb side) of bus.
- At coach parking areas make a clear area near door of approx 2 m x 3 m for passengers to congregate after disembarking.
- Screen car parking from picnic areas by use of earth mounding and shrub planting - even a low vegetation screen will help to reduce visual impact.
- Ensure that 'disabled' car parks are linked to the facility by disabled accessible paths.
- On steeper slopes design parking areas along the contour and terrace between rows where necessary.
- Where possible design car parks to provide shade. Avoid locating car parks under pine trees where cones are likely to fall and damage vehicles.
- Check for dangerous trees and branches before siting car parks.

ONE WAY

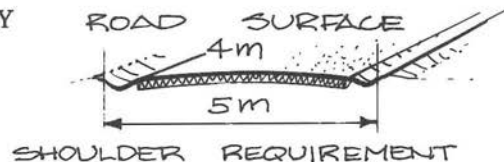
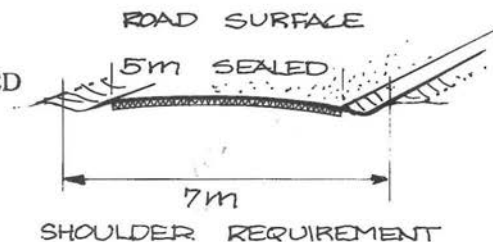
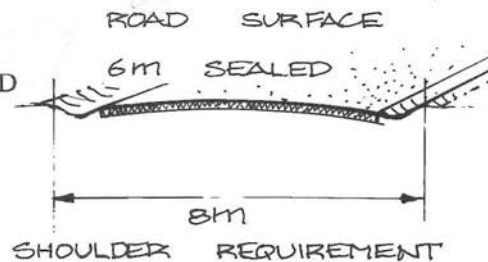
TWO WAY  
15-50 Km SPEEDTWO WAY  
50-80 Km SPEED

- The design and quality of roads will often determine the type of visitor and ultimately the type of activities that take place in a particular area.
- Road design can be used as a management tool to avoid user conflict. The level of road design maintenance will often influence the visitors perception of management and the likely recreation experience.
- Select road material to match local soil colour. Generally a bitumen sealed road will blend with the natural setting.
- Ensure that gravel roads can be maintained by standard equipment - which is generally a grader.



Poor design.

Better design.

- Slope bank and batter angle to improve stability and driver vision.
- A wider shoulder width may also improve sight lines.
- Roads should intersect at right angles.



Y Junction.

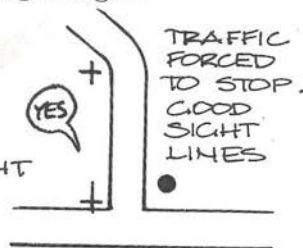

T Junction.

- Gravel thickness - 150 mm compacted depth.  
Table drain depth - 100-200 mm.
- A culvert must be installed at the base of every grade where drainage is likely to be impeded.
- The size of culvert required depends on conditions and the maximum incidence of rainfall. The following table is a guide showing maximum watersheds for a range of pipe sizes south of Perth \*

Pipe Diameter (mm)	Maximum Catchment Size (ha)
30	36
37.5	56
45	80
60	144
75	244
90	324

## Reference

\* CALM Manual of Hardwood Logging Specifications .

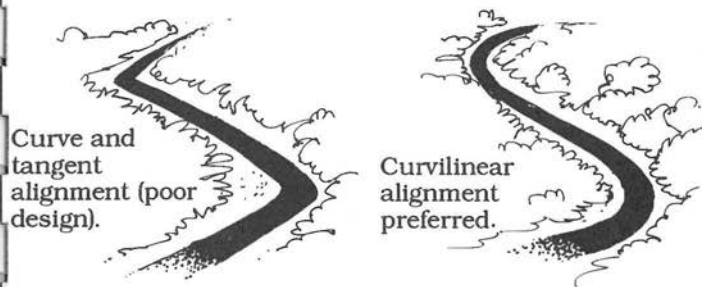

Align roadway with topography - preferably low in the landscape and following natural boundaries.

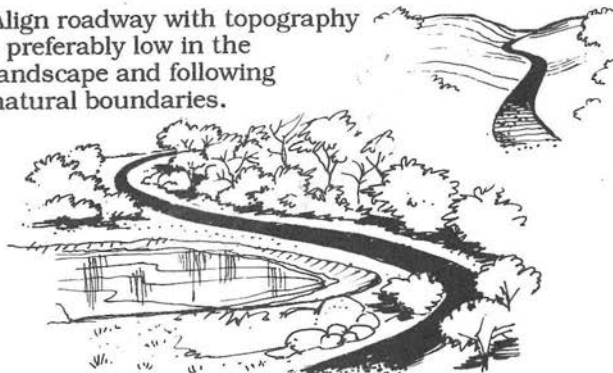

Add variety and interest by aligning the road to incorporate different roadside views and natural focal points.

Vary the location of road within the corridor to provide variety.

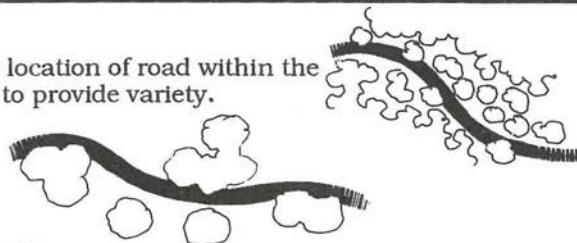

Align road to preserve vegetation within chosen maximum speed and safety guidelines.



Signs and clearings for vistas should be kept close to the axis of the road but away from bends where driver concentration is critical.

ACTIVITY AREA

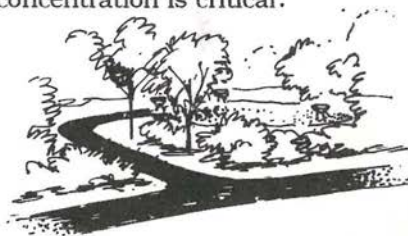

PLAN

Curve alignment of entry road to limit visual penetration and reduce traffic speed.

GENERAL MINIMUM RADII

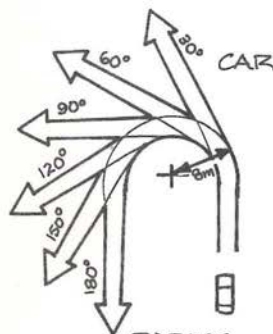

RADIUS  
8 m  
TURNING SPEED  
5/15 Km / HOUR

PATH OF OVERHANG

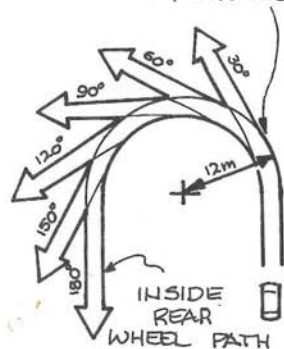

RADIUS  
12 m  
TURNING SPEED  
15/20 Km / HOUR

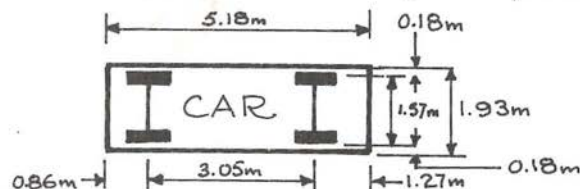

NOT TO SCALE

# TURNING RADII

18

GENERAL MINIMUM RADII TRUCK/COACH

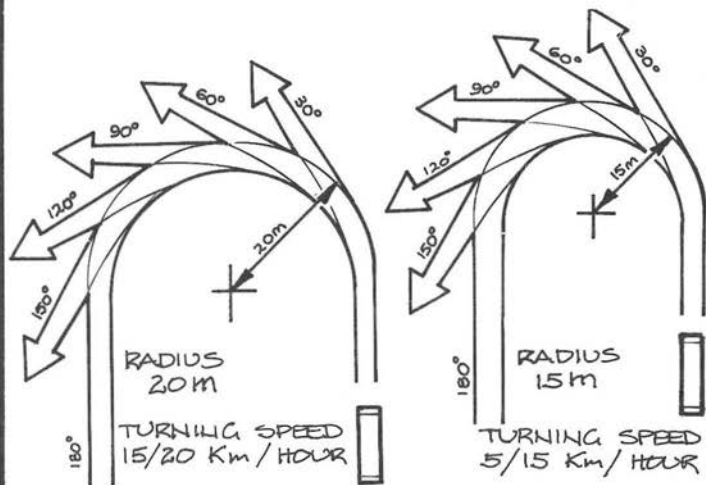

SINGLE UNIT TRUCK / BUS

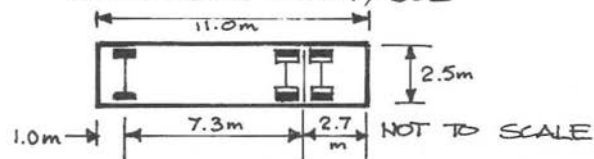

# TURNING RADII

19

GENERAL MINIMUM RADII- SEMI TRAILER

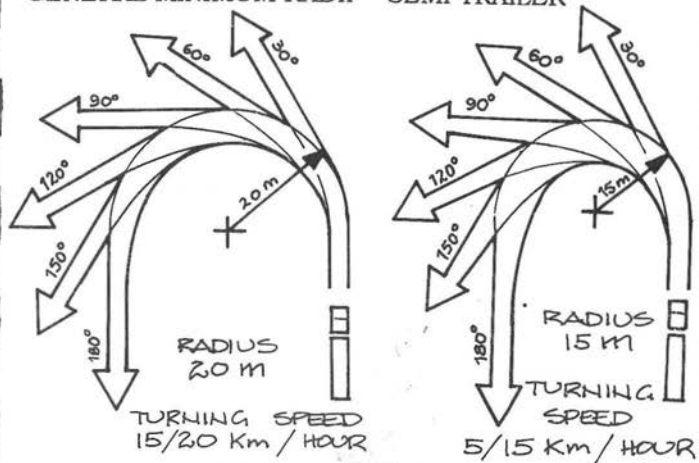

Semi Trailers (17.0 m)

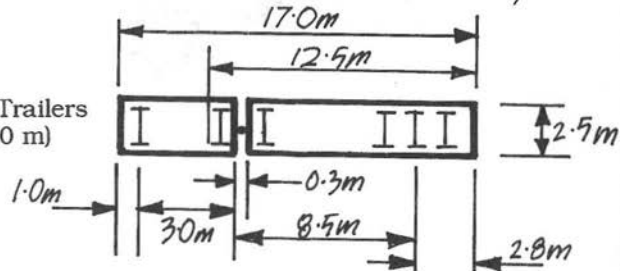

## TYPES OF RETAINING WALLS



Gravity wall relies on mass of wall to resist lateral pressure of the soil behind it.

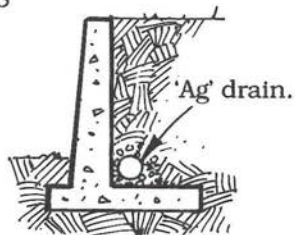

Cantilever wall relies on weight of soil on footing or 'in ground' section to resist lateral pressure (horizontal thrust).

## MOST COMMON RETAINING WALL FAILURES

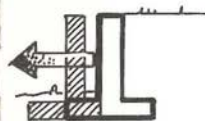

Sliding



Overturning



Settling

## TIPS FOR GRAVITY RETAINING WALL DESIGN

J2

- A 900 mm high retaining wall should be at least 450 mm wide. For every additional 300 mm in height increase width by 150 mm.

In Western Australia the design of any retaining wall over 1000 mm in height should be checked by a civil engineer.



Increase thickness as the wall gets taller.

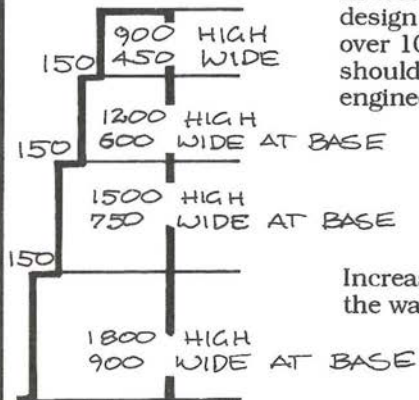

- A wall should be constructed on firm foundation material. The ends of the wall should be disguised to blend with natural slope.
- Drainage should be provided to divert water from behind the wall. An 'Ag' drain should run the entire length of the wall.

## RETAINING WALLS

J3

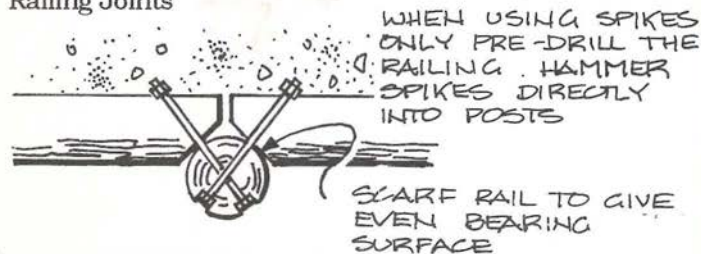
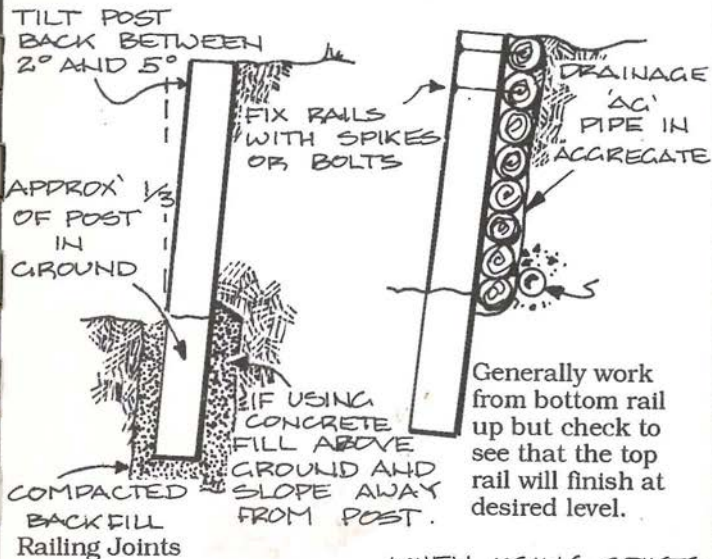

## TIPS FOR CONSTRUCTING RETAINING WALLS

J4

- Check post alignment and brace before backfilling. Put bole end of pole in ground (except when pile driving).
- Use level or stringline to ensure that heights are correct.
- Place 'no-fines rubble' or aggregate at base of posts for drainage and, where required, install perforated pipe.
- Ensure drainage has suitable outflow point.
- Align posts - crown to base - to ensure horizontal level is maintained.
- Consider terracing in very steep locations.

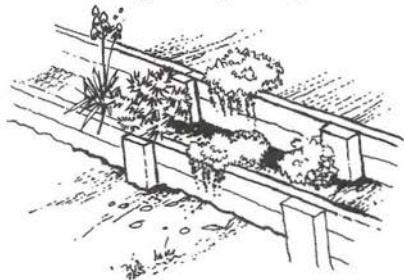

## RETAINING WALLS

J5

### STONE WALLS

Recommended minimum width top course 450 mm.

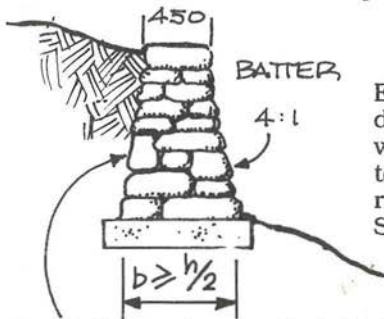

Ensure that the dimensions of the wall are adequate to provide the required mass. See figure J2.

- Avoid placing stone so that the long side is vertical.
- Each stone used in a dry (no mortar) wall should be sufficiently overlapped to bond wall together as a stable mass.
- Top and bottom courses of the wall should use the larger and most stable stones.

## TIPS FOR CONSTRUCTING RETAINING WALLS

J6

- Local stone is usually the most aesthetically suitable for wall construction - particularly on walking trails.
- When local stone is not available use stone that is similar in colour to the local soil.
- If importing stone from another quarry order extra material so the builder/mason has a good choice of rock.
- Ensure that any stone brought in by machine can actually be lifted by the builder or expensive mechanical equipment will be required.
- Avoid machine damage to stone when using bush rock.

## RUBBISH COLLECTION AND DISPOSAL

K1

- There are two major methods of dealing with rubbish.
  1. Provide bins at recreation sites and remove deposited rubbish to refuse tip.
  2. Not to provide bins and encourage visitors to take their rubbish with them.
- Provide bins in collection points at camping areas where visitors stay two or more nights.
- Don't provide bins in day use areas but erect signs informing the visitor of the management strategy and environmental consequences of rubbish and indiscriminate waste disposal.

## RUBBISH COLLECTION AND DISPOSAL

K2

### SYSTEMS TO CONSIDER

#### Individual Bins

Widespread distribution throughout use area. High maintenance component and regular disposal required. Can have significant impact.

#### Cluster of Bins

Useful where access for maintenance is difficult and usage is concentrated in small area. Need to be well sited to ensure use. Avoid bins being visually dominant.

#### Collection Trailer

Good for site which receives specific peaks in usage and where bins are otherwise unnecessary. Easy to maintain. System can also utilise large bins hired for specific times.

#### Distribution of Plastic Bags

Useful in areas where visitors are dispersed at site where bins have been recently removed. The personal approach during distribution is advantageous.

## RUBBISH DISPOSAL

K3

- Where no bins have been provided in a day-use area the maintenance programme needs to ensure that any litter is picked up regularly.
- The standard and presentation of the recreation area will influence how successful the 'no bin' strategy will be.
- Visitors are more likely to take their litter/rubbish with them if the site is clean and tidy.



See CALM Sign Manual Section PG 8.3

## BINS

K4

A typical bin for camping areas.

Can be painted to suit local landscape.

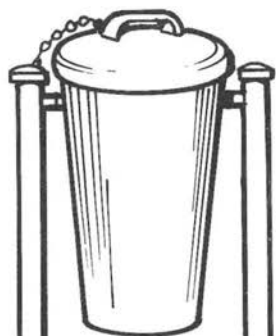

- 60 litre galvanised bin with lid chained to upright.
- Bin swings for easy cleaning.
- Accepts plastic bag inserts (60 l)
- Can be single or dual post system.

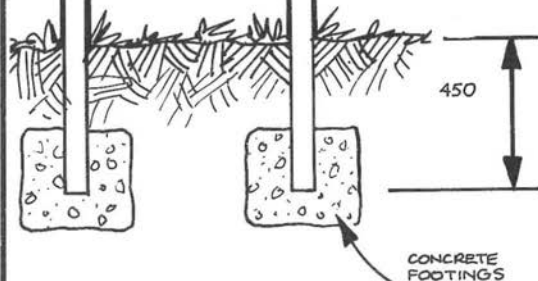

## ROOFS AND SHELTERS

L1

### ROOF ANGLES

3 degrees - 8 degrees flat roofs - deep metal profiles.

10 degrees - 12 degrees minimum slope for corrugated iron.

15 degrees - tile minimum slope.

22.5 degrees - steep roof in Australian setting.

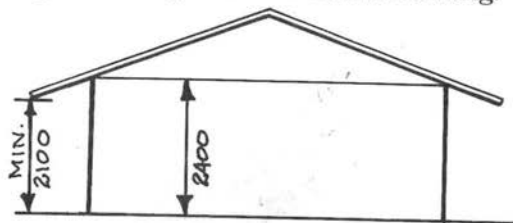

Extend metal cladding over fascia - it looks better and reduces water on fascia.

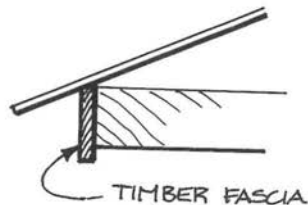

- Avoid having roof line finish directly above the point where visitors stand to read information.
- Additional roof also protects graphic presentations from sunshine.

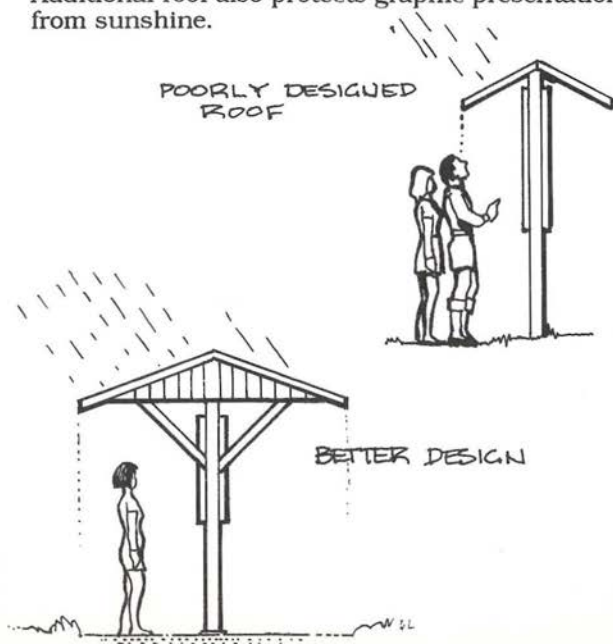

## GUIDE FOR FASTENER USE

- Use non staining fasteners.
- Always fasten a thinner member to a thicker member.
- In framing and construction work a nail should be long enough to penetrate the receiving board a distance of twice the thickness of the thinner board, but not less than 40 mm.
- Coach screws should be long enough to penetrate the receiving board at least the thickness of the thinner (outside) board but not less than 30 mm.
- Wood and Tek screws should penetrate the receiving board a distance of seven times the screw diameter.
- Avoid end grain nailing - if unavoidable, use screws or side grain wood cleat adjacent to end grain member.

## FASTENERS

M2

### ● Bolt Use

Washers should be used under the nut on all bolts and under the head on hexagonal head bolts. In softer woods, such as pine, use larger washers under cup-head (carriage) bolts. Holes should be exact size of bolt diameter.

### ● Coach Screws

Use plain flat washers under head. Use lead hole to full depth - do not over tighten.

### ● Tips to reduce splitting of boards when nailing

- Blunt the nail point.
- Pre-drill 3/4 of nail diameter.
- Use smaller diameter nails and greater number.
- Stagger nails.
- Place nails no closer to the edge than one half board thickness and no closer to end than the board thickness.

## FASTENERS

M3

### BOLTS AND SCREWS

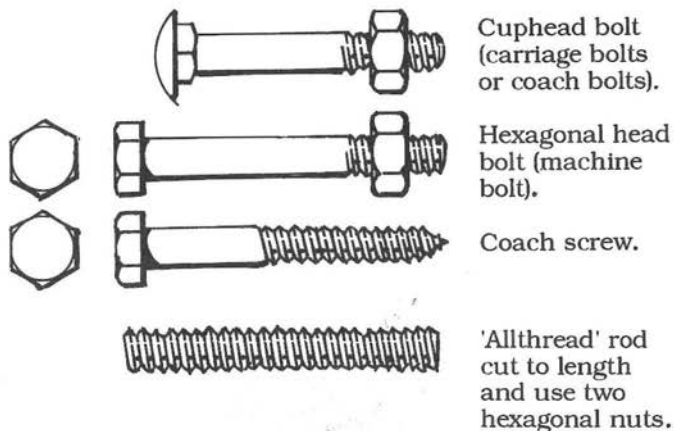

Cuphead bolt  
(carriage bolts  
or coach bolts).

Hexagonal head  
bolt (machine  
bolt).

Coach screw.

'Allthread' rod  
cut to length  
and use two  
hexagonal nuts.

- 'Allthread' comes in various thicknesses and finishes. It is generally in lengths of 600-900 mm. Longer lengths are also available.
- If cutting 'Allthread' with bolt cutters its best to have a nut already on the bolt which can be removed thus clearing any burring on the cut end.

# TEK SCREWS

M4

COLOUR MATCHED GLASS FILLED NYLON MOULDED HEADS



**TYPE 17**

Sheeting to timber purlins



**DRILL KWICK**

Sheeting to steel purlins



**NEEDLE POINT**

Stitching sheeting to sheeting



**SEALING FLANGE**

Valley wall fixing

**TYPE 17**

SELF DRILLING SCREWS FOR TIMBER

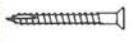

**COUNTERSUNK HEAD**

Timber to timber

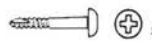

**PAN HEAD**

Sheeting to timber



**WAFER**

Kliplok secret fixing



**HEXAGON HEAD**

Sheeting to timber purlins

**NEEDLE POINT**

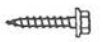

**HEXAGON HEAD**

Stitching sheeting to sheeting

THREAD TYPE/DRILL CAPACITY

GAUGE	T P I	MAX. DRILL CAPACITY
6	20	2.3 mm TOTAL THICKNESS
8	18	2.5 mm TOTAL THICKNESS
10	16	4.5 mm TOTAL THICKNESS
10	24	4.5 mm TOTAL THICKNESS
12	14	4.5 mm TOTAL THICKNESS
12	24	5.3 mm TOTAL THICKNESS
14	10	3.0 mm TOTAL THICKNESS
14	20	6.3 mm TOTAL THICKNESS

SELF DRILLING SCREWS FOR METAL



**SELF EMBEDDING HEAD**



**COUNTERSUNK HEAD**

Timber to steel purlins



**PAN HEAD**



**WAFER HEAD**

Kliplok secret fixing



**HEXAGON HEAD**

Sheeting to steel purlins

STAINLESS STEEL THREAD FORMING SCREWS PRE-DRILLED HOLES



**TYPE A POINT**



**TYPE B POINT**

**GYPSUM SCREWS**



**DRILL KWICK**

Plasterboard to steel studs



**NEEDLE POINT**

Plasterboard to light gauge steel and timber studs

**HOW TO SPECIFY**

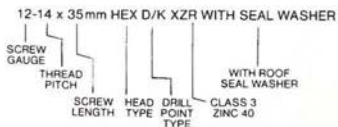

# NAILS

M5

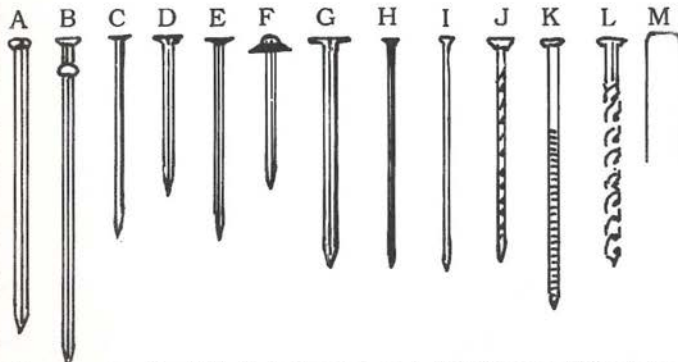

Types of nails: (A) plain brad head, (B) duplex, (C) plain flat head, (D) countersunk, (E) cement coated, (F) galvanised, (G) spring head roofing, (H) T-head machine, (I) barbed, (J) twisted, (K) annually grooved, (L) helically grooved, (M) staple.

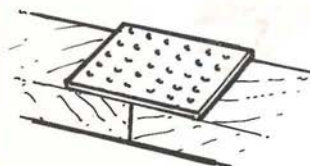

**NAIL PLATES**

Rectangular plates of galvanised steel sheet with punched holes. Fastened by nails driven through holes.

Plates replace solid timber, plywood splice or gusset plates at joints in structures and have some effect in reducing splitting of timber.

## FASTENERS

M6

Rectangular  
toothed connector  
(truss plate).



Toothed plate connectors are made from 1 mm to 2 mm thick galvanised steel with a pattern of teeth punched over the whole surface. Some are designed for manual assembly with a hammer. They are available in a wide range of sizes and with a variety of forms and lengths of teeth.

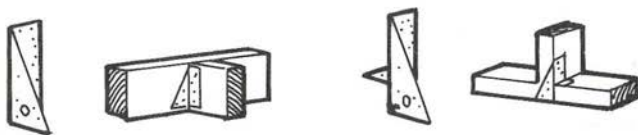

Angle shaped connectors.

Angle shaped plates - plates of galvanised sheet steel are bent to various shapes and are prepunched ready for nailing. Used for joining rafters and ceiling joists to wall plates, and joists to beams. Because the nails are loaded at right angle to their axis, the joints are much more rigid and reliable than skew nail joints in which the nails are loaded in withdrawal. Angle shaped plates are particularly suitable for localities where high winds are common.

## EARTHWORKS

N1

- The goal for earth shaping is to integrate change so well that after revegetation the new landform will appear undisturbed.
- As a general rule shape soil so that the landform curve at the intersection of new and modified land is concave - this shaping often requires additional fill material.

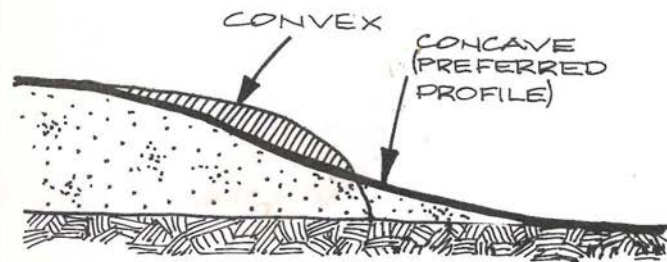

## TIPS FOR EARTHWORKS

N2

- Imported (loose) soil will compact when placed on site and worked. The volume 'lost' can vary from 10% to 25%.
- When having soil delivered measure one or more truck loads to accurately record volume imported. To do this spread the soil level while still on the truck and calculate volume.

This check is very important when payment is based on volume delivered.

## EARTH SHAPING

N3

FLOW LINES



- Avoid rock lined drains.
- Avoid angular drains - slumping will occur.
- Remove or spread excavated material.

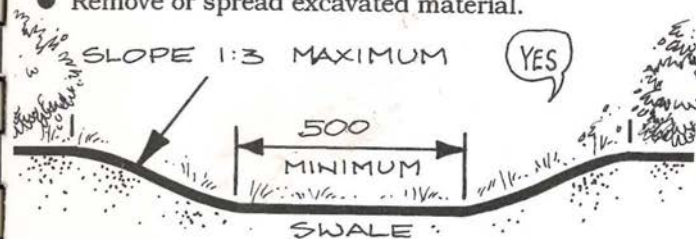

- It is better to have wide, shallow, flat bottomed drainage swale. They are easier to integrate into the finished landform, easier to maintain and are less likely to erode.

- Where possible use local soil - if not practicable then:
  - Remove sufficient local soil to generously cover imported fill material.
  - Backfill with imported material and shape.
  - Spread stored local material over reshaped landform.
- When creating earth mounds or banks much more fill is usually needed than is expected - plan to win and cart more than is anticipated.
- Shape project area to final landform prior to respreading topsoil. Coverage will be greater where surface is relatively smooth. A large volume of topsoil can be 'lost' filling in hollows.

- Recreation should be an enriching experience for all people. It must therefore be physically accessible to the widest range of people providing for the maximum independence, participation and enjoyment.
- As with the rest of the population people with disabilities have different abilities, interests and training. They do not want separate facilities and are used to living in a world not designed for them. Remember - disabilities may include sight, hearing, intellectual capacity, broken bones, restrictive diseases such as arthritis - not just being confined to a wheelchair.
- *For specific details see references. Many of the designs in this booklet cater for total access.*

*"Access to the Natural Environment" A Planning Guide published by W A Department of Sport and Recreation.*

*"Outdoor Access for All" published by Department of Youth, Sport and Recreation, Victoria.*

- Loose gravel paths, particularly on slopes restricts many users.
- Small rises even 20 mm or less can restrict a wheelchair at a door or path.
- Access from the car park to the recreation area often provides more barriers than the recreation activity.
- Branches overhanging trails restricts visually impaired visitors.
- When planning a trail give thought to 'on grade' routes to provide disabled access. If the decision is made at the planning stage it is generally easy to cater for the disabled.
- Maximise use of ramps instead of steps.
- Sign post facilities suitable for disabled visitors.
- When designing facilities to cater for specific disabled visitors seek assistance from target group.