

Agency Guide to Cave and Mine Gates 2009



**Jerry Fant, American Cave Conservation Association
Jim Kennedy, Bat Conservation International
Roy Powers, Jr., American Cave Conservation Association
William Elliott, Missouri Department of Conservation**

Agency Guide to Cave and Mine Gates

August 2009

Jerry Fant (ACCA) Jim Kennedy (BCI)
Roy Powers, Jr. (ACCA) William Elliott (MDC)

Sponsored by:

American Cave Conservation Association
Bat Conservation International
Missouri Department of Conservation

Contents:

Introduction	1
Why gate?	2
Placement of gates and variations on the standard design	4
Gate Design Specifications	8
Construction timing	10
Gate Contractors	11
Post-gating Actions	12
Resources	13
Selected reading live	15

Introduction

This guide is not intended to become a how-to manual on building gates to protect cave and mine resources, or to reduce liability at those sites, particularly abandoned mines. It is, however, intended to guide resource managers in making the best decisions on why, how, when, and who should build such gates. Over the years many hundreds, if not thousands, of gates have been constructed across the United States to secure cave and mine entrances. Some are good, being both secure and ecologically transparent. Others, poorly planned and designed, have had severe detrimental effects on the very resources they were built to protect. Over the years, much research by the American Cave Conservation Association, Bat Conservation International, and the US Fish and Wildlife Service has helped aid in the evolution of cave and mine gates, to the point where we now know what features are essential. An “industry standard” design with variations is now widely accepted by the National Park Service, US Fish and Wildlife Service, Bureau of Land Management, US Forest Service, NGOs such as The Nature Conservancy and the National Speleological Society, and many state wildlife agencies and conservation departments. Many years have been put forth in this endeavor, but techniques and designs still continue to evolve, and it is imperative to stay abreast of the latest advances and not rely on older information.

The designs discussed in this guide are the current industry standard airflow design gates in use in much of the United States. If building gates more than a year or so past the date of this publication, please contact the ACCA or BCI for the latest updates. Contact information is in the Resources section at the end of this Guide.

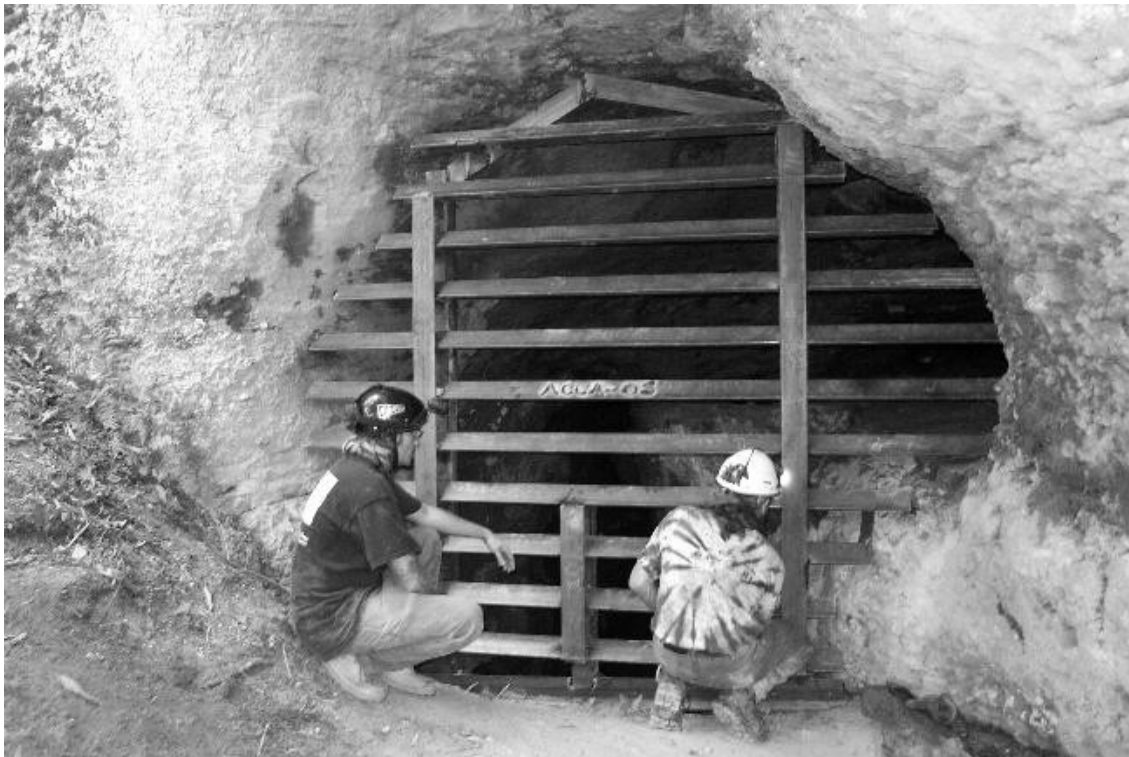

Standard Airflow Design – Bacon Cave-Lower Entrance, Virginia - Photo Jim Kennedy

Why gate?

The decision to gate is never easy. On the downside, there are the costs of construction and the disruption of the natural aesthetics. First and foremost, you must ask yourself what resources and threats are there? Are there cultural remains? Are there endangered species? Or are there inherent dangers present? If the answer to the first two questions is yes, to what point are they threatened? Can the site withstand minimal impact? If so, can signage alone detour the casual visitor? If you are making the decision to gate a cave based on inherent danger, there are many state laws which already grant protection from such visitation. You should consult your attorney before making your decision, as in some instances the gate may actually increase your liability. Abandoned mines, of course, are a very different story.

Below is a simplified flowchart to aid in decision-making. In most cases there will be many more factors involved in making the final decision to gate a cave.

SOME QUESTIONS TO BE ASKED BEFORE DECIDING TO GATE

Administrative convenience — Is the gate being planned simply because the agency doesn't have the experience or resources to provide more active, involved management? Would limited resources be better used for signage and public education?

Animal exclusion — Many animals are essential components of the cave ecosystem. Not only do they seek shelter in the caves/mines, but they also produce much needed nutrients for other cave/mine dwelling organisms.

Liability concerns — Most states have laws protecting landowners from liability associated with allowing free access to their caves, and gates are not necessary. However, abandoned mines are automatically considered human health hazards, and closure is the first option. Gating a mine instead of a permanent physical closure may allow the mine to be used by bats and other animals, if suitable, as well as provide continued access to archeological and mineralogical resources.

Historical remains — Are there archeological or paleontological resources in the cave or mine that are threatened by visitation and in need of protection?

Rare or endangered species — Does the cave/mine contain species which are listed on a state or federal rare or endangered species list, meriting additional protection?

Vandalism — Is cave/mine threatened by vandals, looters, and trespassers? Has the cave shown past evidence of such? If not, will conditions soon change which will put the cave in danger of such activities?

Stewardship — Does a vigilant owner or manager live nearby, or does someone visit the area often enough that intruders will be seen or heard as they enter the site?

Other closure methods — Can other controls be used, such as road gates, signs, surveillance, etc.? Can other measures be used to control access to the site? All of these measures still require maintenance and monitoring. Or does the site lend itself to permitted entry? Some caves can withstand seasonal or minimal impact. Will visitors comply with a good permit system if a good permit system is in place? Will visitors stay out of the site during periods of closure?

Gate design — Will the gate comply with current industry standards? The ACCA / BCI designs are accepted by the US Forest Service, Bureau of Land

Management, US Fish and Wildlife Service, National Park Service, many state agencies, and conservation groups across the United States. They are designed to lesson the impact on the area immediate to the gate and to have minimum affect on the site's airflow and thus the microclimate. Over thirty years of research has been invested into these gate designs.

Stakeholder buy-in — Are there valid concerns over the design or placement of the gate? Is another closure method more appropriate? Will the proposed gate location destroy cultural remains, disturb natural settings, or alter the airflow characteristics of the cave/mine?

Contractor suitability — Cave/Mine gating is a technical subject that requires knowledge and experience. General welding contractors and in-house maintenance personnel rarely have the abilities to properly construct a quality gate, even with detailed plans and direct supervision by a knowledgeable agency representative unless that person is an experienced cave gate designer. Knowledge of the site's ecology, especially bats, is necessary before a gate is built.

Monitoring and Maintenance — Are there adequate personnel and resources to periodically check and maintain the gate? Gates must be checked for breaches on a regular schedule and repaired immediately. Locks should be well-maintained, and replaced when broken or malfunctioning. The biological impacts of the gate must also be monitored, to assure that it is not having a negative impact on the site. Is the gate performing its function of protecting the resource while excluding people?

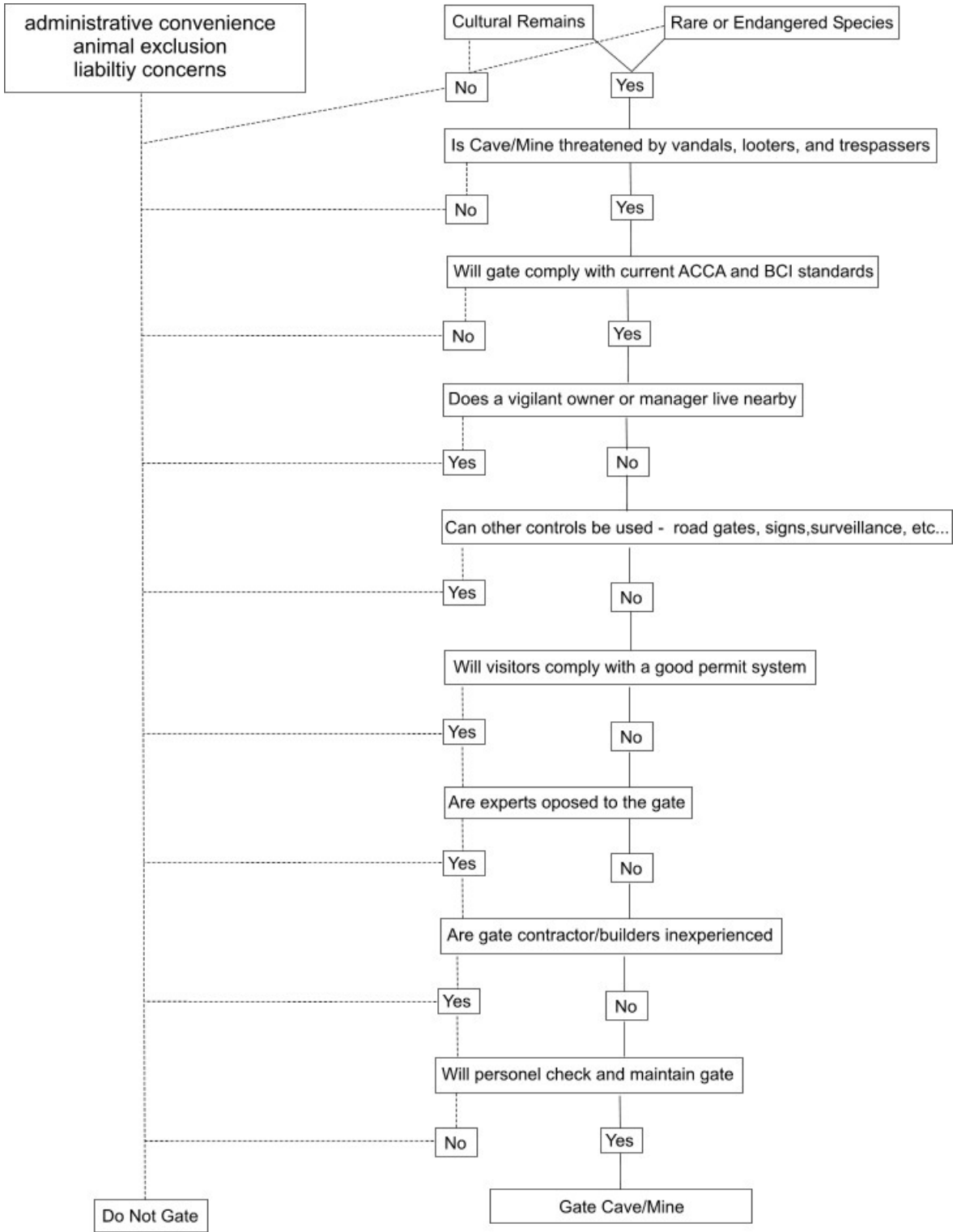

Placement of gates and variations on the standard design

Once the decision is made to proceed to protect the cave or mine with a gate, there are several designs based on specific criteria. One important criterion that is common to all gates is **placement**. Other criteria may be very specific to the type of resource which is to be protected. Much emphasis has been placed on the design of gates in which bats are present. These types of gates are also dependent upon what type of bat is present and the time of year. The standard airflow gate design (basic gate) has proven efficient in protecting other resources such as cultural sites and invertebrate biology.

Placement

The gate should be placed in such an area that does not restrict airflow. This means that the smallest cross-sectional area should not be gated to save on material cost. Restricting the airflow causes changes in the temperature, pressure, and humidity levels deep into the cave or mine. These changes although small have great consequences on the ecosystem. If bats are present, gate placement should also not impede bat flight. Placement of the gate within easy to monitor areas is imperative, as any tampering can then be easily detected.

Basic Gate Design

The Basic Gate Design is a vertically placed flat grid of bars across the cave or mine passage. The spacing of the bars is critical to allow access of small bats and other small mammals, but not wide enough to allow human entry. The bars are constructed of 4" angle iron oriented apex up to maximize the airflow through the gate. Bars are oriented horizontally, with vertical supports spaced widely. The basic design is widely used even where there are no bats currently present.



Basic Gate Design - Rocky Hollow Cave, Virginia - Photo Jerry Fant

VARIATIONS ON THE BASIC GATE DESIGN

Half Gate

The Half Gate, or Fly-over Gate, is a variation of the Basic Gate (sometimes also called a Full Gate). The Half Gate is designed for entrances or passages that have high vertical relief, typically over 20' (6m), and are used most often for large maternity colonies of bats. The bottom of the Half Gate consists of the bottom of a Basic Gate constructed high enough so that a ladder will not reach the top. Special attention must be given to support columns, since they are not attached to the ceiling. Expanded metal mesh is then attached horizontally extending forward (and sometimes rearward, if warranted) to stop attempts at climbovers.



Half Gate, stepped to ground contour - Great Spirit Cave, Missouri – Photo Mike Slay

Basic Gate with Window

The Basic Gate with Window is also a variation on the standard gate design. The introduction of the window provides a larger protected flight space for bats, similar to the Half Gate or Chute Gate (described below). They can only be constructed in an entrance with an overhanging bluff, or well inside a large passage. The window is placed between a section of horizontal bars with expanded metal extending out on the bottom and sides to prevent persons from climbing over and into the site. This type of gate is also used where there are large numbers of bats present.



Basic Gate with Window – Bacon Cave, Virginia – Photo Jerry Fant

Chute Gate

The chute gate is specifically used on caves or mines in which large numbers of bats inhabit for maternity or hibernacula, but for which the entrance configuration does not allow a Half Gate or Window Gate to be constructed. These gates are a design combination of a Basic Gate and an extended covered Window. The standard part of the gate will sometimes have a Bay Window (see below) added for a cantilever support for the Chute. The Chute extends beyond the Basic Gate at an angle to reach a height greater than a ladder will reach, thereby making entry more difficult for unauthorized persons while permitting unimpeded bat flight. The chute is covered with heavy gauge expanded metal. The size of the chute is determined by the expected number of bats and the physical size of the entrance.



Chute Gate – Grigsby Cave, Virginia – Photo Jerry Fant

Cupola Gate

Also sometimes called a “Cage Gate”, these gates are designed to protect vertical pit and mine entrances. A box of four Basic Gates is built around the vertical opening, a minimum of 4’ (1.2m) in height. The center top opening is then covered with additional angle iron or heavy gauge expanded metal. The height discourages vehicle traffic, and allows bats to slowly gain altitude and fly out the sides of the box, thus avoiding predators.



Cupola Gate,– Saltpetre Cave, Kentucky – Photo Jerry Fant

Some caves or mines may require a variation of different types or styles of gates, but the key components of the Basic Gate should remain. Specifications are covered on the design in the next section. A cave-gating specialist should be consulted during the initial stages of planning. A list of specialists and other resources can be found in the appendix.

Gate Design Specifications

The gate designs developed by the American Cave Conservation Association and Bat Conservation International have been in use for over twenty years. Much research into the integrity, airflow characteristics, and bat use has shown these to be the state of the art in modern cave and mine gating. For this reason major land management agencies and organizations have adopted these designs as their standard. This section covers the general design specifications for these gates. For more information contact the ACCA or BCI or attend one of their sponsored Cave and Mine Gating Workshops.

Basic Gating Materials (all gate material is of mild steel)

Horizontal Bars: 4" x 4" x $\frac{3}{8}$ " thick flanged angle iron

Stiffeners: 1 $\frac{1}{2}$ " x 1 $\frac{1}{2}$ " x $\frac{1}{4}$ " thick flanged angle iron

Columns: 4" x 4" x $\frac{3}{8}$ " thick flanged angle iron

Sill: 4" x 4" x $\frac{3}{8}$ " thick flanged angle iron

Footers: 4" x 4" x $\frac{3}{8}$ " thick flanged angle iron

Header Bar: 4" x 4" x $\frac{3}{8}$ " thick flanged angle iron

Pins: 1" cold rolled steel round bar

Pin Plate: 4" x 4" x $\frac{3}{8}$ " thick flanged angle iron *or*
6" x 6" x $\frac{3}{8}$ " thick flanged angle

Hangers: 6" x 6" x $\frac{3}{8}$ " thick flanged angle iron

Expanded metal: EM3 (4" x 2" diamond raised $\frac{3}{4}$ ")

Bat Guard/Torsion Plate: 4" x $\frac{1}{4}$ " thick flat bar

For Half Gates, Windows, and Chutes (in addition to the above materials)

Main support for expanded metal: 4" x 4" x $\frac{3}{8}$ " thick flanged angle iron

Additional support for expanded metal: 2" x 2" x $\frac{3}{8}$ " thick flanged angle

Expanded metal: EM3 (4" x 2" diamond raised $\frac{3}{4}$ ")

Design

The gate shall have a weight-supporting bottom sill spanning the width of the passage, consisting of 4" x 4" x $\frac{3}{8}$ " thick flanged angle iron. The vertical support columns are connected to the sill at the greatest width possible, but not exceeding 15' (4.6m). The sill and columns rest on solid bedrock floor if possible. If not, they

should rest on an expanded metal (EM3) skirt with at least 2 feet of EM3 both fore and aft of the gate. The columns are supported by 4" x 4" x $\frac{3}{8}$ " thick flanged angle iron footers, which also serve to prevent lifting of the expanded metal. Additional footers may be added as necessary to provide added security for the expanded metal skirt. The vertical columns are ideally plumb to the longitudinal (front to back) axis of the cave, but can be off plumb on the perpendicular axis (side to side) if necessary to take advantage of wall attachment points, or to provide increased bat flight space in irregular passages.

All columns and select horizontal bars are attached to the cave or mine walls with pins cut from 1" cold rolled steel round bar and a minimum of 8" long. They are pounded into 1" holes drilled into the solid bedrock walls, at least 4" deep and preferably 8" or more. The pins are then welded to Pin Plates cut from angle iron with a hole for the pin on one side, which is then welded to the gate itself.

The horizontal bars have two stiffeners inverted and placed inside the 4" x 4" flanged angle and welded to the 4" x 4" angle every three feet of its length. The completed horizontal bar is to be placed on 6" x 6" x $\frac{3}{8}$ " thick flanged angle iron hangers. The hangers are connected to the vertical support columns so that the height from the top of one horizontal bar is 5 $\frac{3}{4}$ " from the bottom of the bar above it.

A 4" x 4" x $\frac{3}{8}$ " thick flanged angle iron header bar is welded to the top of the vertical support columns.

The bat guard/torsion plate is welded to the front side of the hangers on all vertical support columns.

The opening or door should be no less than 38" wide by 13" tall. This allows a loaded rescue litter to be passed through the gate in case of an emergency. Removable bars (see diagram) are the most secure, but can be unwieldy for high-traffic use. In that case, a hinged door panel may be constructed as an alternative, but requires more care in engineering to assure long-term functionality without compromising the structural integrity or security of the gate.

Gates are typically left unpainted. The average projected life of a cave or mine gate is about 20 years. This can be substantially less in areas of extreme weathering, or when attached the gate is installed in a corrosive area. Gate designs continue to evolve, and gates need to be replaced as new and better options become available.

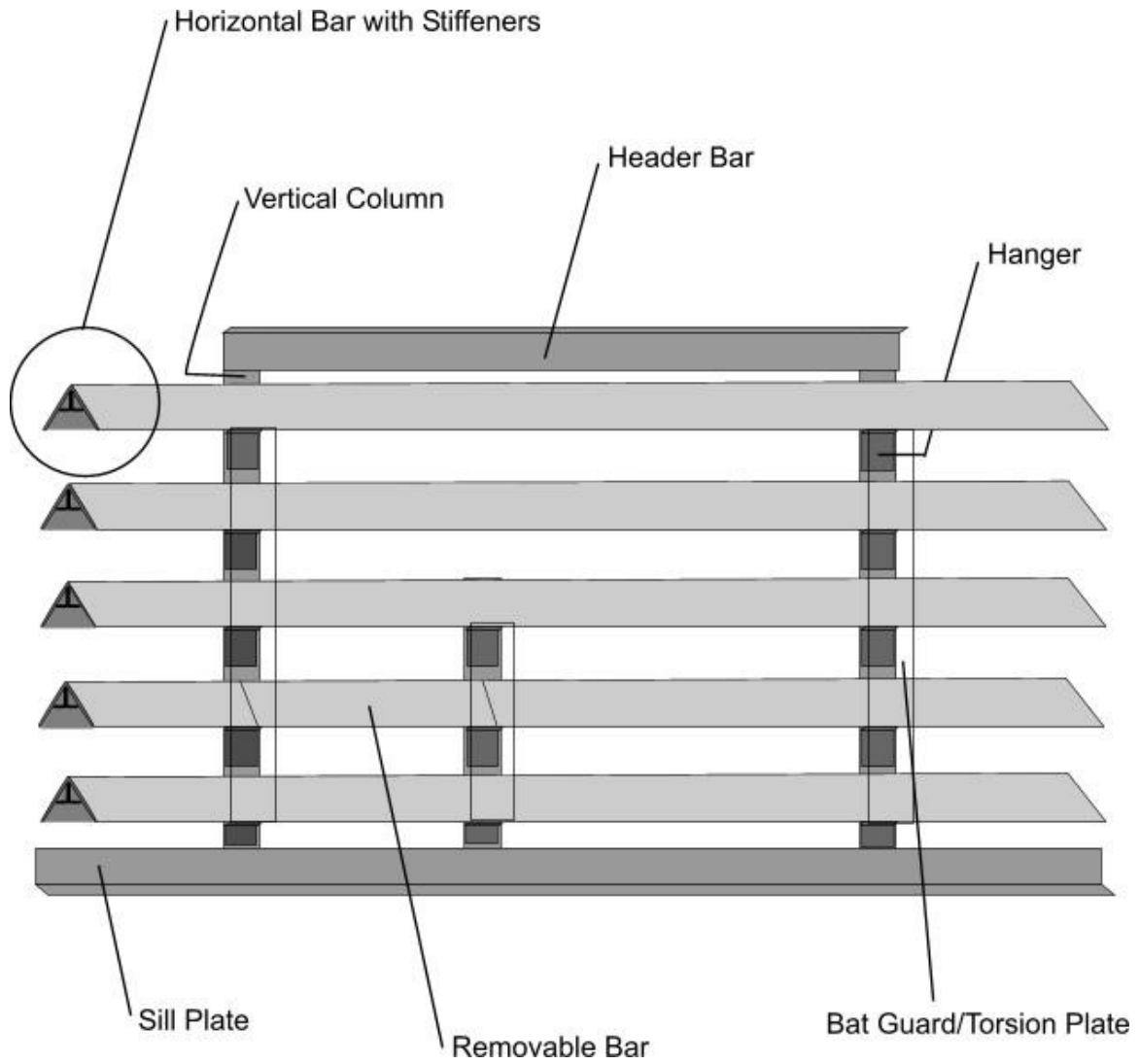

Additional Gate Designs can be found in the appendix.

Construction timing

After the decision is made to gate, as opposed to using some other protective measures, and deciding which type of gate to use, the next decisions involve the timing of the construction when to gate. Special attention must be made to several items, including:

Funding — Appropriate and substantial funding must be approved and secured prior to gating. There are many sources where your funding may come from: grants, contributions, budget approvals, etc...

Seasonality — Weather can play a major factor in the construction of a cave or mine gate. Rainy seasons will hinder the movement of steel to the site along with making the handling of steel extremely dangerous at the gate site. Cold winter temperatures can slow the construction process due to dexterity and site access. If snow and ice are present then site lifting and moving steel will become more dangerous. Extremely high temperatures can present problems with worker dehydration and must be monitored carefully. Any of these conditions can create a hazardous work site and will add considerable time to the construction of the cave gate. Biological impact, such as bat activity, may limit the available working window at the site (see next section below).

Species use — Considerations must be made to the species which inhabit the cave or mine. These species include vertebrates and invertebrates which may be listed as Threatened or Endangered both federally and by state, species which are not listed but are considered at risk (“Species of Concern”), and endemic species. Sites with rare species or high biodiversity are especially important. While some species live deep inside the cave or mine, many others will use the entrance area near where most gates are constructed. With bats, you should avoid any disturbance from gate construction during the summer months if the site is a nursery colony or has other summer use, and during the fall swarming period if the cave or mine is a hibernaculum. Consult with experts if you are unsure of specific dates or usage patterns.

Personnel — Organizing personnel is also important, as it is often difficult to schedule adequate help for the timely completion of the gate. Outside contractors usually present fewer problems, as they will utilize their own personnel, but that convenience comes at a higher price tag. Many gates are built using agency personnel or volunteers, keeping costs to a minimum but creating more logistical headaches. Be sure to schedule the gating project far enough in advance to make use of as many in-house personal and volunteers as necessary if on a tight budget.

Gate Contractors

There are several options for the actual construction of the cave or mine gate. These options are listed in order of preference, listing the pros and cons of each.

Gating Specialists are extremely well versed in the design, placement, and construction of gates in less than optimum conditions. They are knowledgeable of many subterranean ecosystems and their relationship to the construction of the proper gate. Specialists are also experienced with cave and mine microclimates and their relationships to subterranean biota. They are knowledgeable in geomorphology and the engineering processes related to gate construction. Specialists have learned the tricks of the trade, usually increasing the efficiency and construction of the gate process. In most instances cave-gating specialists can build the proper gate in less time than alternative builders. There are very few of these specialists certified in the construction of cave and mine gates, and they usually require travel, lodging, and meal reimbursement added to the cost of the gate. Even with these additional expenses the total budget for hiring a gating specialist is often equal to or less than for other contractors. Many specialists in the field can offer a variety of options affecting the construction costs: full hired crew; supervisor, cutter, and welder (with other labor provided by the agency); or as an on-site advisor for an unrelated crew.

Agency Personnel may include biologists, geologists, botanists, or maintenance departments tasked with the management of local cave and mine resources. While there may well be excellently trained and dedicated people working in those fields, they usually lack the overall knowledge and engineering required to properly address each aspect of designing, placing, and constructing a cave or mine gate. In-house gating projects may be generally cost effective, but may require several times longer to complete due to other obligations of the persons involved. For example a cupola-style gate constructed at a National Park took 6 weeks whereas a gating specialist could have completed the same gate within 9 days. Gating workshops are scheduled periodically to assist those decision makers in understanding the ins and outs of the gating process, helping them to decide which options are available and what might work best for their sites.

Outside Consultants/Welding Contractors are generally the most expensive and least qualified to construct cave gates. Although the actual welding may be exceptional, the overall knowledge of the underground resources and potential impacts on them is practically non-existent. Even with detailed plans these contractors will have the most difficulty with equipment and personal in less than optimum conditions. And their lack of experience will be especially apparent if confronted with a non-standard gate. Without the proper training and certification, the time for the outside contractor to build a quality gate may be 4 to 6 times longer than the specialist.

There are many aspects in the construction of a cave gate that requires much experience to learn. A bad gate design and project practices put many things in jeopardy, ranging from resource impact to worker safety. Detrimental results of a bad gate design may not show for many years. Improper placement of the gate may cause premature failure, compromising site security. With the limited resources available, it is always best to do it right the first time.

Post-gating actions

Scientific monitoring, such as temperature and other microclimate changes and biological inventories, should be carried out before and after gate building in order to have a yardstick by which to measure the effects of the gate, if any. If a bat site, it is critically important to document bat acceptance of the gate, and any behavioral changes, positive or negative, that occur as a result. Monitoring of the gate itself for signs of attempted illegal entry and vandalism must also be done on a regular basis to keep the site secure and prevent further damage, more expensive to repair.

We cannot state strongly enough the need for post-gate monitoring. Once the gate is completed the typical agency response is to assume their concerns over visitation and vandalism are over, and the site can then be blissfully ignored. This is not the case. No gate should be installed before a management plan has been developed for the resource. This management plan should include a monitoring schedule which includes the following:

1. *Periodic checks for structural stability.* Is the gate, and the bedrock to which it is attached, still structurally sound? Are erosion or freeze/thaw cycles affecting surrounding rock and jeopardizing site security? Are the steel or welds weathering faster than expected, resulting in weaknesses that can be easily exploited?

2. *Periodic checks for vandalism.* Has the gate been breached? Typical ways to circumvent the gate are digging under the gate, breaking the rock wall around the gate, digging another entrance, bending the bars, breaking a weld, cutting the bars, cutting the lock, or climbing over (if a Half Gate, Window Gate, or Chute Gate). On rare occasions, vandals will even forcibly remove the entire gate.

3. *Periodic checks for erosional effects from natural processes.* Is there an accumulation of debris building up around the gate? This can cause gates to fail when water-flow is encountered. It can also block natural airflow currents, which in turn disturb the microclimate.

4. *Periodic checks for opening functionality.* Locks need regular attention, requiring cleaning, lubrication (with graphite powder), or even replacement. Even McGard button head bolts need occasional lubrication, without which they become hard or even impossible to open. Doors and removable bars should be opened periodically, to ensure that the gate has not settled, rendering them inoperable.

5. *Periodic checks for biological integrity.* A site that has been gated to protect a population of bats or other animals, including invertebrates, must maintain a fairly narrow set of parameters to keep those populations healthy. If the gate is not ensuring those conditions, then it must quickly be modified, or even removed or replaced. Pre-gate monitoring of temperature, humidity, and animal abundance and distribution provides simple baseline data by which post-gate conditions can be compared. Pre-gate monitoring is highly recommended before any gate project is undertaken.

A breached gate that is not repaired rapidly is not protecting the resources from human threats. There are many natural forces that can also damage a gate, such

as tree falls, rock falls, siltation, freezing and thawing, aging (rust), and running water. Checks should include close visual inspections as well as manual investigations. Vandals can be quite clever, sometimes cutting a bar, replacing it on the gate, and disguising it with mud to make it appear uncut. Often the breached area is away from the actual door or removable bar entry point, making it less likely to be noticed. Some vandals will go to extreme measures to destroy a gate or gain entry to a protected resource. A good monitoring schedule should be maintained monthly, or at a minimum of every six months in remote areas. Once a problem has been noted it should be repaired immediately.

Resources

Organizations offering expert advice on cave and mine gating

American Cave Conservation Association

119 East Main Street
Horse Cave, KY 42749-1112
270-786-1466
<http://www.cavern.org/acca/accahome.html>

The ACCA is the leader in zero airflow reduction gate design and can provide information on gate design and construction. Their magazine, American Caves, is an excellent source for gating success stories.

Bat Conservation International, Inc.

Post Office Box 162603
Austin, TX 78716-2603
512-327-9721
<http://www.batcon.org>

BCI has a Cave and Mine Resources Specialist who is very knowledgeable about gate design, placement, construction, and monitoring. They also maintain a database of information and publications on bat gate design and construction, and a list of gate consultants who are knowledgeable in bat behavior and ecology. Their magazine, Bats, often showcases cave and mine conservation projects.

Select agencies with personnel knowledgeable in gating issues

Missouri Department of Conservation

Cave Lab, Runge Conservation Nature Center
Post Office Box 180
Jefferson City, MO 65102-0180
573-522-4115
http://www.utexas.edu/tmm/sponsored_sites/biospeleology

MDC will consult or assist with cave gate design and construction within the Missouri area. They have fielded several gating projects dealing with a number of different species.

The Nature Conservancy, Tennessee chapter

2021 21st Avenue South, Suite C-400

Nashville, Tennessee 37212-4350

615-383-9909

<http://www.nature.org/wherewework/northamerica/states/tennessee>

TNC will consult and assist with cave gates dealing with rare and endangered species as well as important archeological and paleontological sites in the Tennessee area.

Cave Gating Specialists/Consultants

Jerry Fant

American Cave Conservation Association

251 Gold Rush Circle

Wimberley, TX 78676-6004

512-970-0456

jerryfant@verizon.net

Roy Powers

American Cave Conservation Association

Route 1 Box 153

Duffield, VA 24244-9630

276-546-5386

icave@core.com

Jim Kennedy

Bat Conservation International

500 North Capital of Texas Highway, Building 1

Austin, TX 78746-3302

512-327-9721

jkennedy@batcon.org

For others in your area, contact ACCA or BCI.

Selected reading list

Anon. 1985. Volunteers protect Tennessee bats. *American Caves* 1(2):8–9.

Anon. 1993. James Cave receives new gates for bats. *Bats* 11(3):4.

Anon. 1993. BCI helps protect Pennsylvania mine for bats. *Bats* 11(4):16–17.

Anon. 1995. New ACCA gates protect Kentucky and Tennessee caves. *American Caves* 8(1):10–11.

Anon. 1997. Gates, gates, and more gates! *American Caves* 10(1):6–7.

Bobo, K., and J. Greene. The gating of Wolf River Cave. *NSS News* 58(10):283, 286, 294.

Brady, J. T. 1985. Cave management for the endangered Indiana bat (*Myotis*

- sodalis*) and gray bat (*Myotis grisescens*). Pp. 86–95, in 1982 Cave Management Symposia Proceedings (H. Thornton and J. Thornton, eds.). American Cave Conservation Association, Richmond, Virginia. 122 pp.
- Brown, C. B. 1996. Bat habitat in caves: What are the caver's responsibilities? *NSS News* 54(2–3):52–53.
- Burghardt, J. E. 1997. Bat-compatible closures of abandoned underground mines in National Park System units. Pp. 184–195, in Proceedings of the American Society for Surface Mining and Reclamation (J. E. Brandt, ed.). American Society for Surface Mining and Reclamation, Lexington, Kentucky. XXX pp.
- Colburn, M. L. 2005. Paleontological inventory project: vertebrate remains found in select passages and caves in Mammoth Cave National Park. Unpublished report (Technical Report No. 2005-1199-007) to USDI National Park Service. Illinois State Museum Landscape History Program, Springfield, Illinois. 318 pp.
- Currie, R. R. 2002. Response to gates at hibernacula. Pp. 86–99, in *The Indiana Bat: Biology and Management of an Endangered Species* (A. Kurta and J. Kennedy, eds.). Bat Conservation International, Austin, Texas. 265 pp.
- Dutko R. 1994. Protected at last, the Hibernia Mine. *Bats* 12(3):3–5.
- Elliott, W. R. 1996. The evolution of cave gating. *American Caves* 9(2):9–15.
- Elliott, W. R. 2001. Project reports 2000, Missouri caves. *American Caves* 14(3):6–9.
- Elliott, W. R. 2001. Cave Gating Criteria. Unpublished document for the Missouri Department of Conservation. 7 pp. [PDF available at http://www.utexas.edu/tmm/sponsored_sites/biospeleology/pdf/index.htm]
- Elliott, W. R., and R. L. Clawson. 2001. Temperature data logging in Missouri bat caves. Pp. 52–57, in 1999 National Cave and Karst Management Symposium Proceedings (G. T. Rea, ed.). Southeastern Cave Conservancy, Chattanooga, Tennessee. 221 pp.
- Fletcher, M. R. 1985. Endangered bat protection at Buffalo National River, Arkansas. Pp. 147–150, in 1984 National Cave Management Symposium Proceedings (J. E. Vandyke, ed.). *Missouri Speleology* 25(1–4):147–150.
- Forbis, S., V. Haskins, and D. G. Foster. 1996. Protecting the ancient history of Crumps Cave. Pp. 88–92, in 1995 National Cave Management Symposium Proceedings (G. T. Rea, ed.). Indiana Karst Conservancy, Indianapolis, Indiana. 318 pp.
- Hathorn, J., and J. Thornton. 1987. The common sense guide to cave gates. ACCA Cave Management Series 1(3):23–45. American Cave Conservation Association, Horse Cave, Kentucky. XXX pp.
- Hathorn, J., and J. Thornton. 1993. Cave gates, design and construction considerations. Pp. 359–363, in 1991 National Cave Management Symposium Proceedings (D. L. Foster, D. G. Foster, M. N. Snow, and R. K. Snow, eds.). American Cave Conservation Association, Horse Cave, Kentucky. 405 pp.
- Hopper, H. L. 1999. Cave gating, three success stories. *American Caves* 12(3):6–9.
- Hunt, G., and R. R. Stitt. 1975. *Cave Gating* (2nd edition 1981). National Speleological Society, Huntsville, Alabama. 60 pp. [Use these books for historical reference only—gate designs are outdated.]
- Kennedy, J. 2004a. Restoration, not just conservation, of bat caves — need, methods, and case study of a *Myotis sodalis* hibernaculum. Pp. 93–100, in 2003 National Cave and Karst Management Symposium Proceedings (G.

- T. Rea, *ed.*). National Cave and Karst Management Symposium Steering Committee, Gainesville, Florida. 117 pp.
- Kennedy, J. 2004b. Training opportunities for cave and mine gaters. Pp. 89–93, *in* Bat Gate Design, a technical interactive forum (K. C. Vories, D. Throgmorton, and A. Harrington, *eds.*). USDI Office of Surface Mining, Alton, Illinois. 452 pp.
- Kennedy, J. 2004c. Pre- and post-gate microclimate monitoring. Pp. 353–357, *in* Bat Gate Design, a technical interactive forum (K. C. Vories, D. Throgmorton, and A. Harrington, *eds.*). USDI Office of Surface Mining, Alton, Illinois. 452 pp.
- Kennedy, J. 2006. On cave gates. Pp. 147–165, *in* Cave Conservation and Restoration (V. Hildreth-Werker and J. C. Werker, *eds.*). National Speleological Society, Huntsville, Alabama. 614 pp.
- Kennedy, J., and C. Whitney. 2004. Ecological restoration at Saltpetre Cave, Carter Caves State Resort Park, Carter County, Kentucky. Kentucky Karst (Kentucky Speleological Survey) 2(1):6–9.
- Kennedy, J., and R. Powers. 2005. Bat gates for large colonies and maternity sites. Pp. XX–XX, *in* 2005 National Cave and Karst Management Symposium Proceedings (G. T. Rea, *ed.*). National Cave and Karst Management Symposium Steering Committee, Huntsville, Alabama. 261 pp.
- Ludlow, M. E., and J. A. Gore. 2000. Effects of a cave gate on emergence patterns of colonial bats. Wildlife Society Bulletin 28(1):191–196.
- MacGregor, J. 1993. Responses of winter populations of the federal endangered Indiana bat (*Myotis sodalis*) to cave gating in Kentucky. Pp. 364–370, *in* 1991 National Cave Management Symposium Proceedings (D. L. Foster, D. G. Foster, M. N. Snow, and R. K. Snow, *eds.*). American Cave Conservation Association. Horse Cave, Kentucky. 405 pp.
- Martin, K. W., D. M. Leslie, Jr., M. E. Payton, W. L. Puckette, and S. L. Hensley. 2003. Internal cave gating for protection of colonies of the endangered gray bat (*Myotis grisescens*). Acta Chiropterologica 5(1):143–150.
- Martin, K. W., D. M. Leslie, Jr., M. E. Payton, W. L. Puckette, and S. L. Hensley. 2006. Impacts of passage manipulation on cave climate, Conservation implications for cave-dwelling bats. Wildlife Society Bulletin 34(1):137–143.
- Murphy, M. 1993. Restoring Coach Cave. Bats 11(3):3-5.
- Nieland, J. 1996. Washington's Christmas Tree Cave gated—Bats protected. American Caves 9(2):16–17.
- Olson, R. 1996. This old cave—The ecological restoration of the Historic Entrance ecotone of Mammoth Cave, and mitigation of visitor impact. Pp. 87–95, *in* Proceedings of the Fifth Annual Mammoth Cave Science Conference. National Park Service and Cave Research Foundation, Mammoth Cave, Kentucky. XXX pp.
- Powers, R. D. 1985. General cave gate considerations. Pp.77–79, *in* 1982 National Cave Management Symposium Proceedings (H. Thornton and J. Thornton, *eds.*). American Cave Conservation Association, Richmond, Virginia. 122 pp.
- Powers, R. D. 1993. Design improvements for gating bat caves. Pp. 356–358, *in* 1991 National Cave Management Symposium Proceedings (D. L. Foster, D. G. Foster, M. N. Snow, and R. K. Snow, *eds.*). American Cave Conservation Association. Horse Cave, Kentucky. 405 pp.

- Powers, R. D. 1996. A study of acoustical confusion. Pp. 274–276, in 1995 National Cave Management Symposium Proceedings (G. T. Rea, ed.). Indiana Karst Conservancy, Indianapolis, Indiana. 318 pp.
- Pugh, M., and J. D. Altringham. 2005. The effect of gates on cave entry by swarming bats. *Acta Chiropterologica* 7(2):293–299.
- Quinn, M., and J. Petterson. 1997. A grand effort in the Grand Canyon. *Bats* 15(3):4–7.
- Raesly, R. L., and J. E. Gates. 1986. Winter habitat selection by north temperate cave bats. *American Midland Naturalist* 118(1):15–31.
- Richter, A. R., S. R. Humphrey, J. B. Cope, and V. Brack, Jr. 1993. Modified cave entrances: thermal effect on body mass and resulting decline of endangered Indiana bats (*Myotis sodalis*). *Conservation Biology* 7(2):407–415.
- Roebuck, B. E., A. Vakili, and L. Roebuck. 2001. Cave gate airflow disturbance: a qualitative study. Pp. 169–175, in 1999 National Cave and Karst Management Symposium Proceedings (G. T. Rea, ed.). Southeastern Cave Conservancy. Chattanooga, Tennessee. 221 pp.
- Roebuck, L. 2000. Gating in Tennessee: a plethora of summer bat protection projects. *American Caves* 14(1):6–8.
- Spanjer, G. R. 2004. How do bats react to cave gates? *NSS News* 62(10):285.
- Spanjer, G. R. 2004. Behavioral responses of bats to cave and mine gates. MS Thesis, York University, Toronto, Ontario. 89 pp.
- Stihler, C. W. 2000. Gates constructed to protect bats in West Virginia caves. *American Caves* 13(2):15–16.
- Toomey, R. S., M. L. Coburn, and R. A. Olson. 2002. Paleontological evaluation of past use of caves by the Indiana bat: a significant tool for restoration of hibernacula. Pp. 79–85, in *The Indiana Bat: Biology and Management of an Endangered Species* (A. Kurta and J. Kennedy, eds.). Bat Conservation International, Austin, Texas. 265 pp.
- Tuttle, M. D. 1977. Gating as a means of protecting cave-dwelling bats. Pp. 77–82, in 1975 National Cave Management Symposium Proceedings (T. Aley and D. Rhodes, eds.). Speleobooks, Albuquerque, New Mexico. 152 pp.
- Tuttle, M. D., and D. E. Stevenson. 1978. Variation in the cave environment and its biological implications. Pp. 108–121, in 1977 National Cave Management Symposium Proceedings (R. Zuber, J. Chester, S. Gilbert, and D. Rhodes, eds.). Adobe Press, Albuquerque, New Mexico. 141 pp.
- Tuttle, M. D. 1985. Joint effort saves vital bat cave. *Bats* 2(4):3–4.
- Tuttle, M. D. 1997. A Mammoth discovery. *Bats* 15(4):3–5.
- Tuttle, M. D. 2000. Where the bats are, part III: caves, cliffs, and rock crevices. *Bats* 18(1):6–11.
- Tuttle, M. D. 2003. Estimating population sizes of hibernating bats in caves and mines. Pp. 31–39, in *Monitoring trends in bat populations of the United States and Territories, problems and prospects* (T. J. O’Shea and M. A. Bogen, eds.). U. S. Geological Survey Information and Technology Report USGS/BRD/ITR–2003–0003. 282 pp.
- Tuttle, M. D., and J. Kennedy. 2002. Thermal requirements during hibernation. Pp. 68–78, in *The Indiana Bat: Biology and Management of an Endangered Species* (A. Kurta and J. Kennedy, eds.). Bat Conservation International, Austin, Texas. 265 pp.
- Tuttle, M. D., and D. A. R. Taylor. 1998. *Bats and Mines*, revised edition. Resource Publication No. 3. Bat Conservation International, Austin, Texas. 50 pp.
- Twente, J. W., Jr. 1955. Some aspects of habitat selection and other behavior of cavern-dwelling bats. *Ecology* 36(4):706–732.

Vories, K. C., D. Throgmorton, and A. Harrington, eds. 2004. Bat Gate Design: a Technical Interactive Forum. USDI Office of Surface Mining, Alton, Illinois. 452 pp.

Werker, J. C. 2006. Materials considerations for cave installations. Pp. 167–174, *in* Cave Conservation and Restoration (V. Hildreth-Werker and J. C. Werker, eds.). National Speleological Society, Huntsville, Alabama. 614 pp.

White, D. H., and J. T. Seginak. 1987. Cave gate designs for use in protecting endangered bats. *Wildlife Society Bulletin* 15:445–449.

Gate Designs

4" x 4" x 3/8" Angle Sill Plate

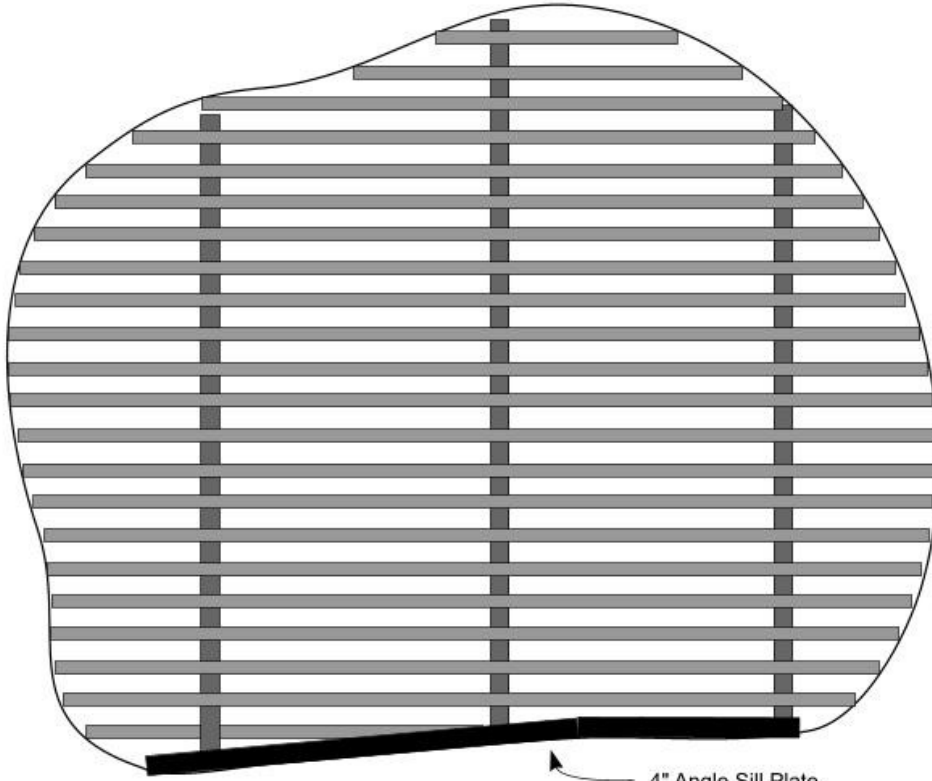

Use 4" Sill Plate to conform to passage floor

4" x 4" x 3/8" Angle Sill Plate Design B Splice Detail

Where the sill plate breaks to follow floor contour
a splice of 4" angle a minimum of 12" must be
welded to join two sill plates together

Profile View

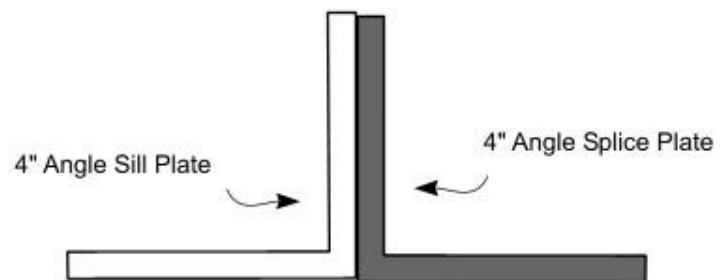

Plan View

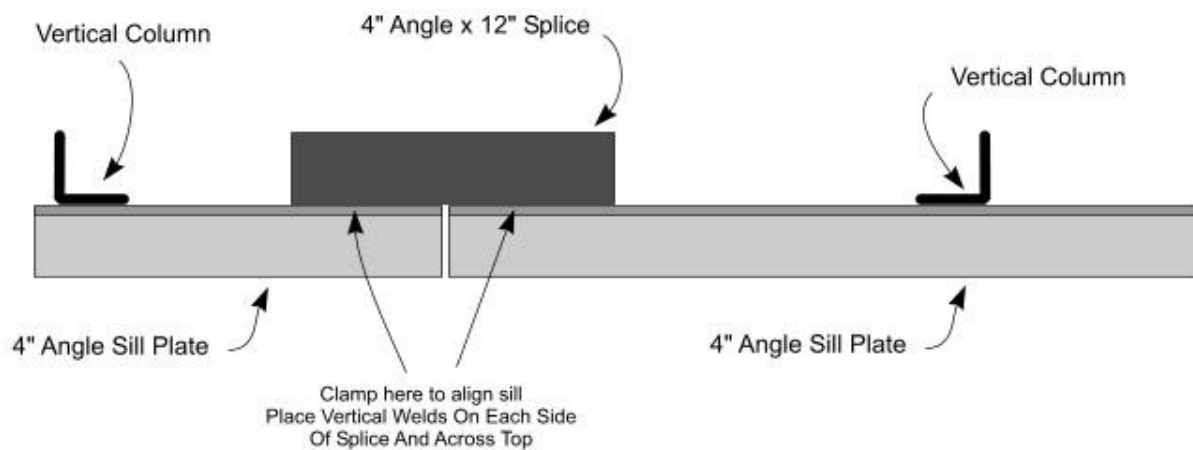

ACCA Angle Iron Cupola Design Basic Gate

Horizontal Bar Design with Stiffener

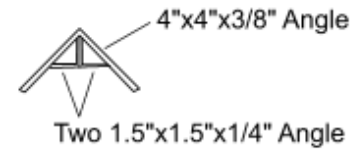
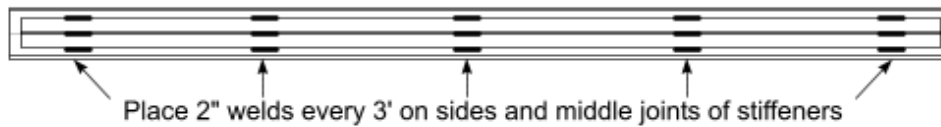

Vertical Column
4"x4"x3/8" Angle

Front View

Top Plate
4"x4"x3/8" Angle

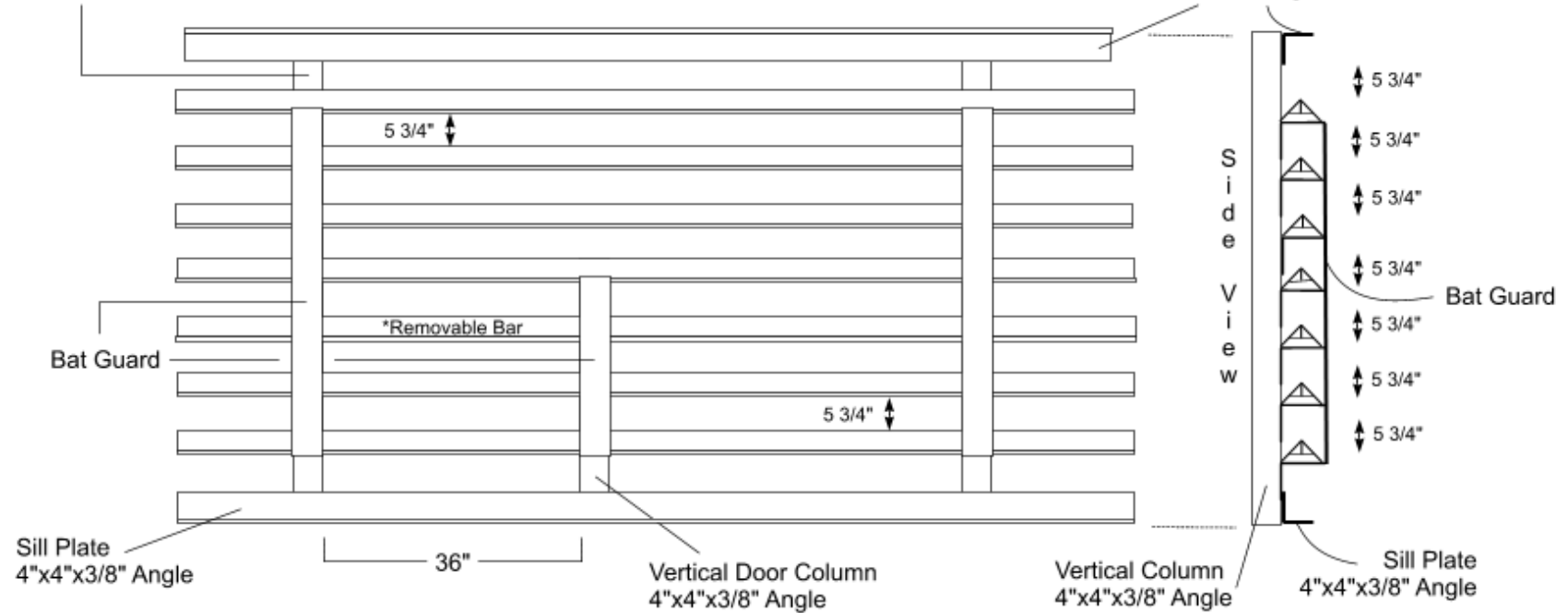

*See specifications for Removable Bar



ACCA Angle Iron Design Basic Adit Gate

Horizontal Bar Design with Stiffener

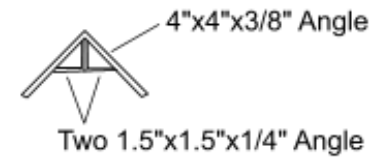
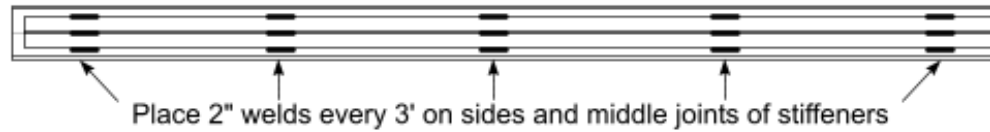

Vertical Column
4"x4"x3/8" Angle

Front View

Top Plate
4"x4"x3/8" Angle

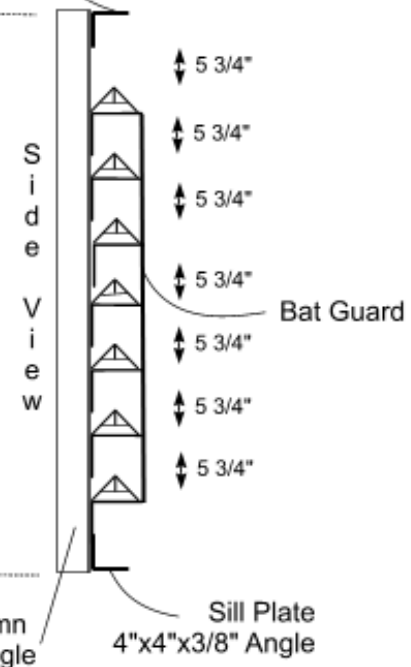
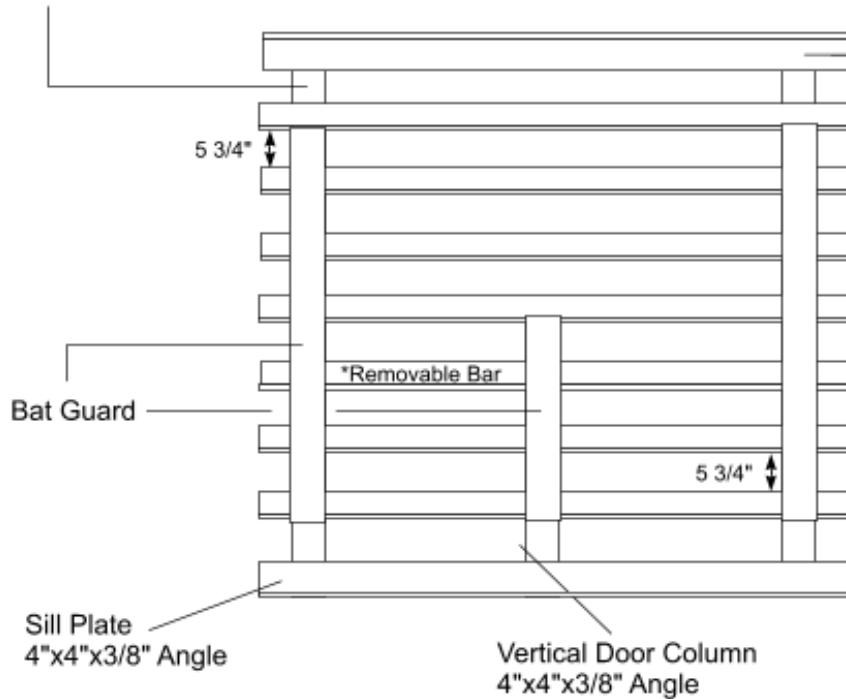

*See specifications for Removable Bar



ACCA Angle Iron Cupola Design Sides

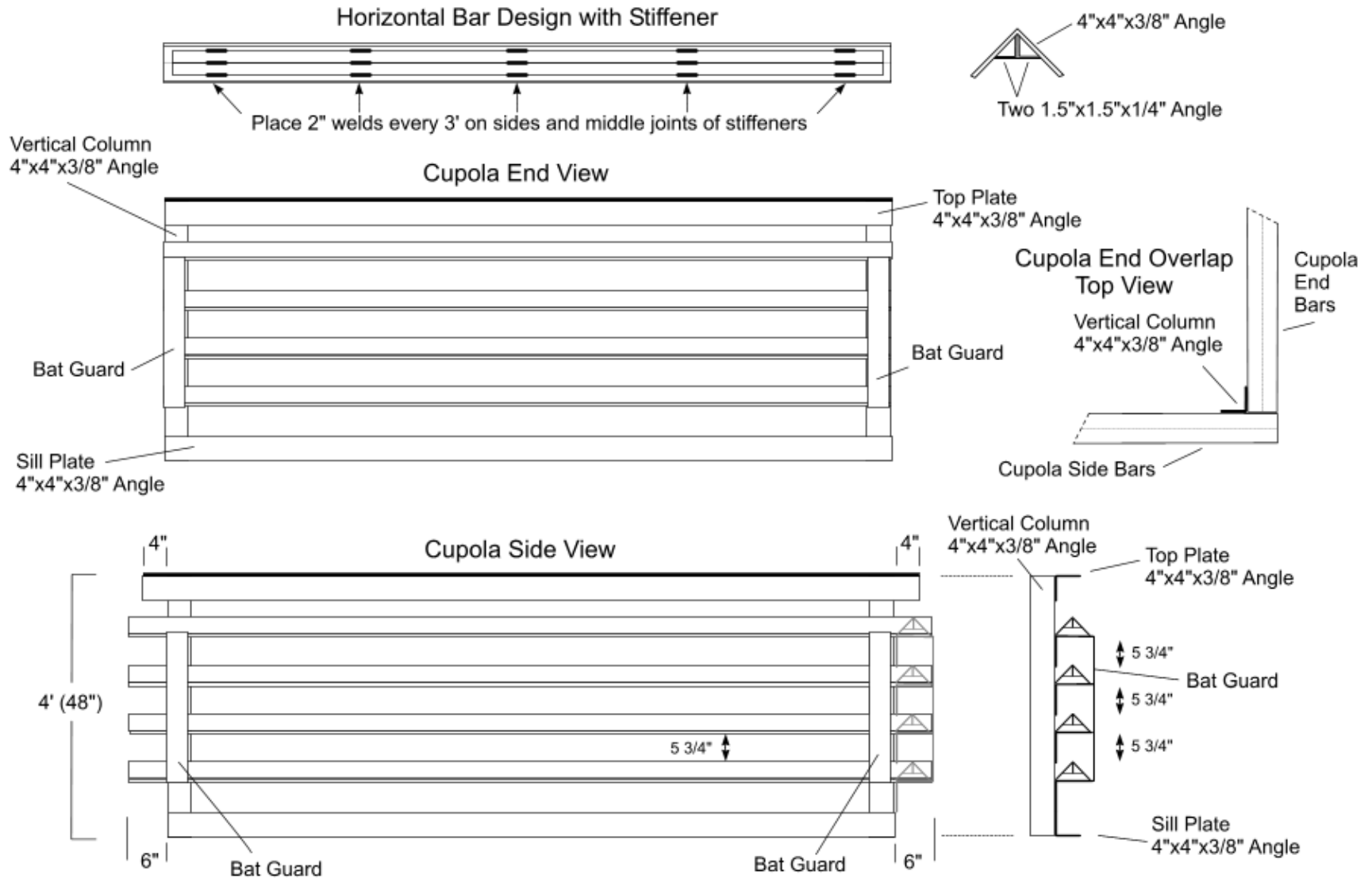

Draft By Jerry Fant 2009



ACCA Angle Iron
Cupola Design
Sides

© ACCA 2009

ACCA Angle Iron Cupola Design Sides Option A

Horizontal Bar Design with Stiffener

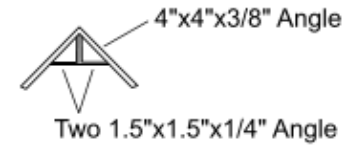
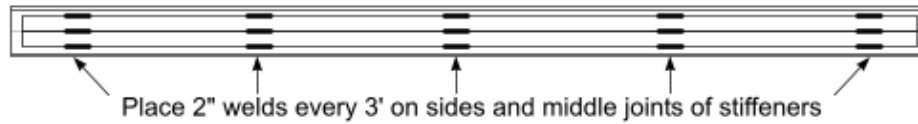

Vertical Column
6"x6"x3/8" Angle

Cupola Front and Side Views

Top Plate
4"x4"x3/8" Angle

Vertical Column
6"x6"x3/8" Angle

Top Plate
4"x4"x3/8" Angle

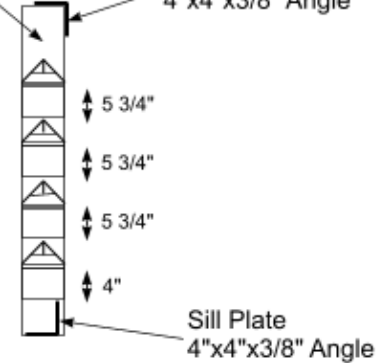
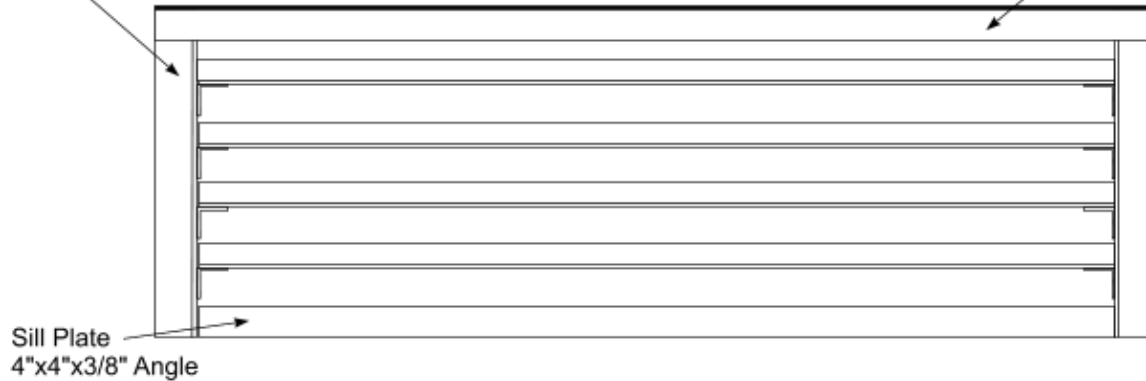

Horizontal Bar

Cupola Top View Two Corners
Minus Top Plate for Clarity

Horizontal Bar

Horizontal Bar

Vertical Column
6"x6"x3/8" Angle

Front View
Hanger and
Horizontal Bar
Connection

Vertical Column
6"x6"x3/8" Angle

Horizontal Bar

Hanger
4"x4"x3/8" Angle
6" Long

Vertical Column
6"x6"x3/8" Angle

Top Plate Corner

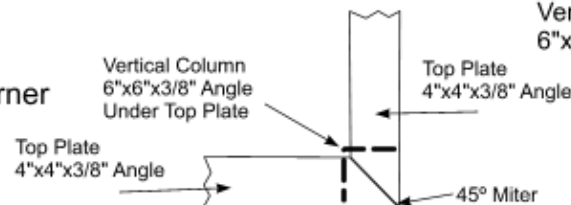

ACCA Angle Iron
Cupola Design
Sides Option A

© ACCA 2009

ACCA Angle Iron Cupola Design Top

Expanded Metal EM3

Top Plate
4"x4"x3/8"

Vertical Columns
4"x4"x3/8"

*Design for Cupola Tops less than 12'

Lateral Supports
4"x4"x3/8"

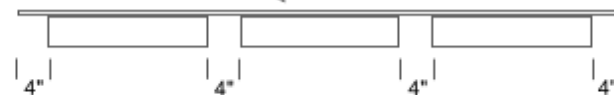

Cut 4" web at each intersection
with cross members and top plate

Cross Member Supports
4"x4"x3/8"

Cross Member Support

Top Plate



Hanger
4"x4"x3/8" Angle
3 1/2" Wide



ACCA Angle Iron
Cupola Design
Top

© ACCA 2009

ACCA Angle Iron Gate Design Footers and Ground Sheathing

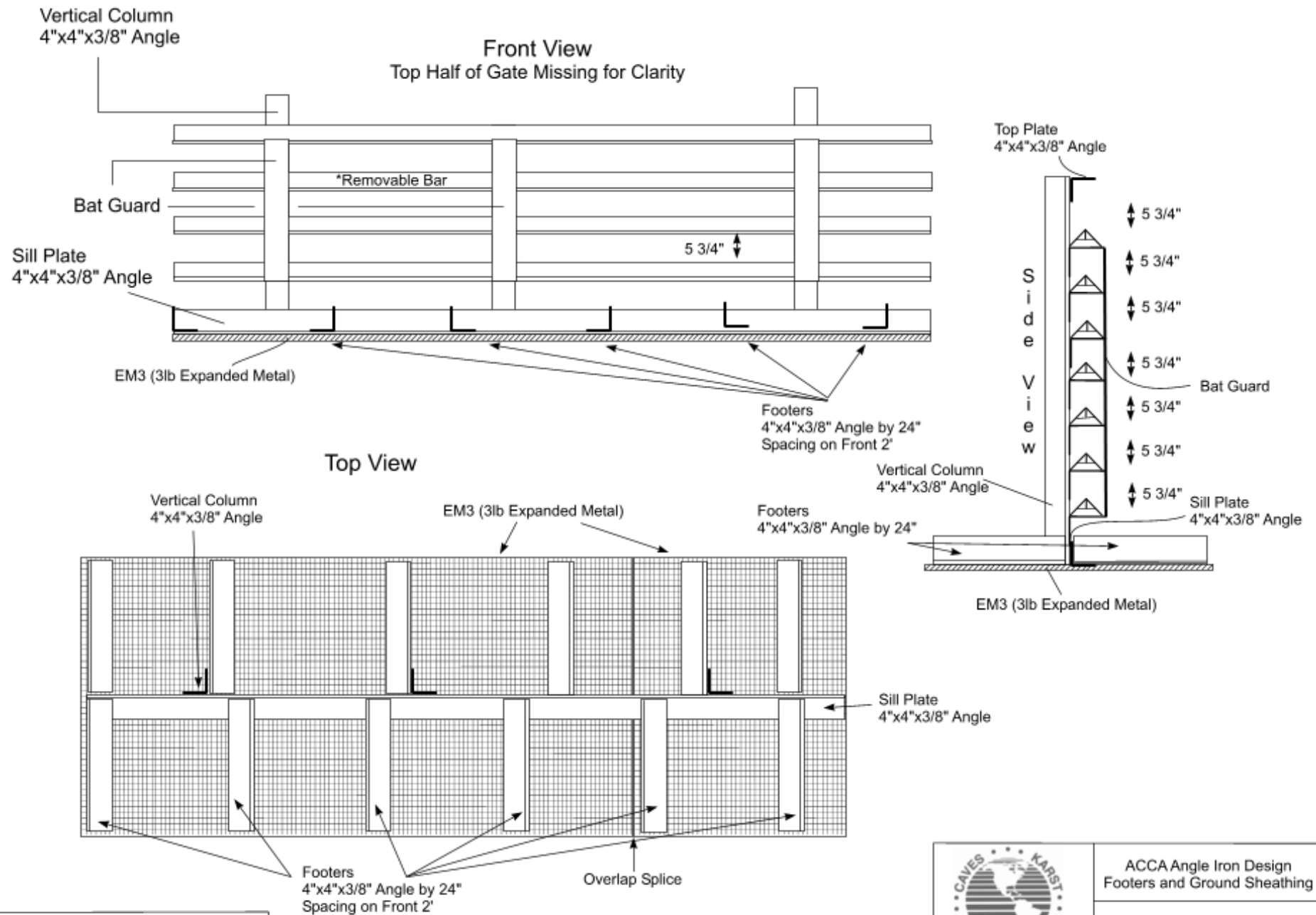

Draft By Jerry Fant 2009



ACCA Angle Iron Design
Footers and Ground Sheathing

© ACCA 2009

ACCA Angle Iron Gate Design Removable Bar

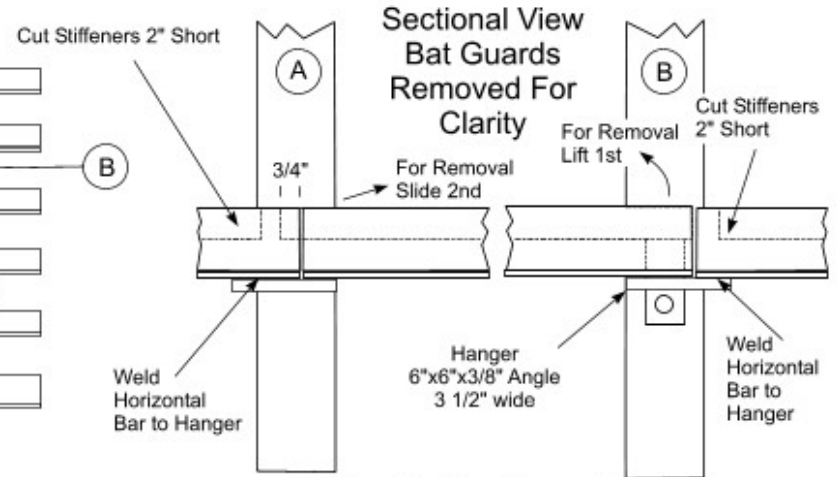
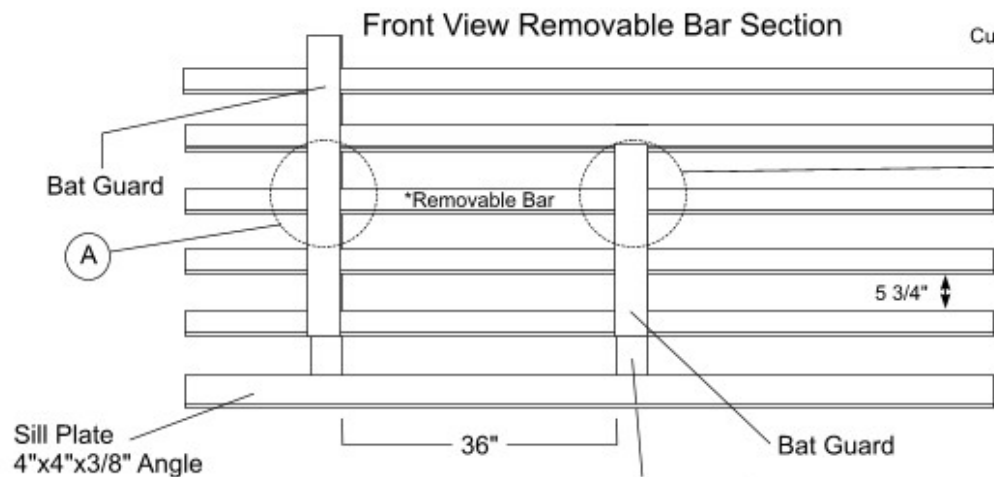
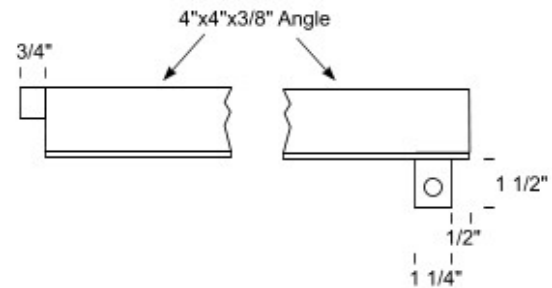
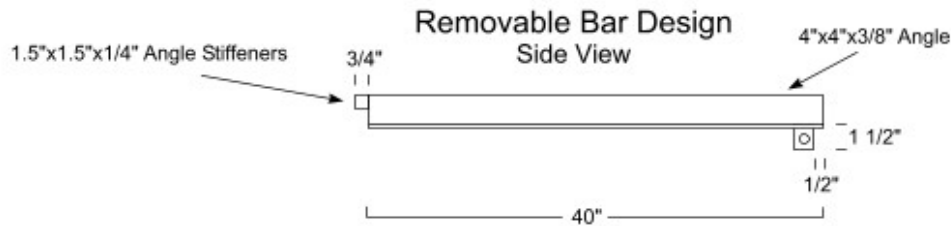
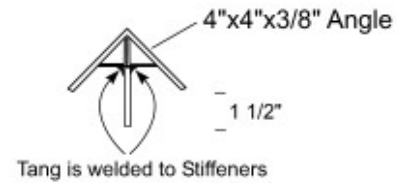
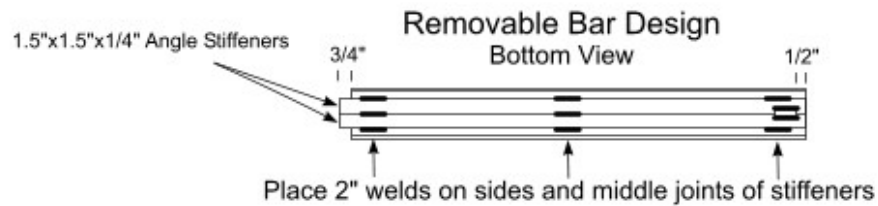

*Careful not to weld removable Bar to Hangers

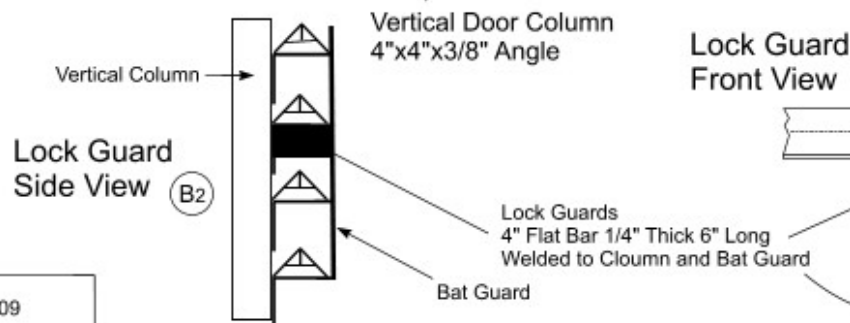

ACCA Angle Iron Removable Bar Design

© ACCA 2009

BAT CAVE SKYLIGHT ENTRANCE VERTICAL PROFILE VIEW LOOKING WEST

NOTE:

Gate assembly to meet American
Cave Conservation Association,
Bat Gate specifications.

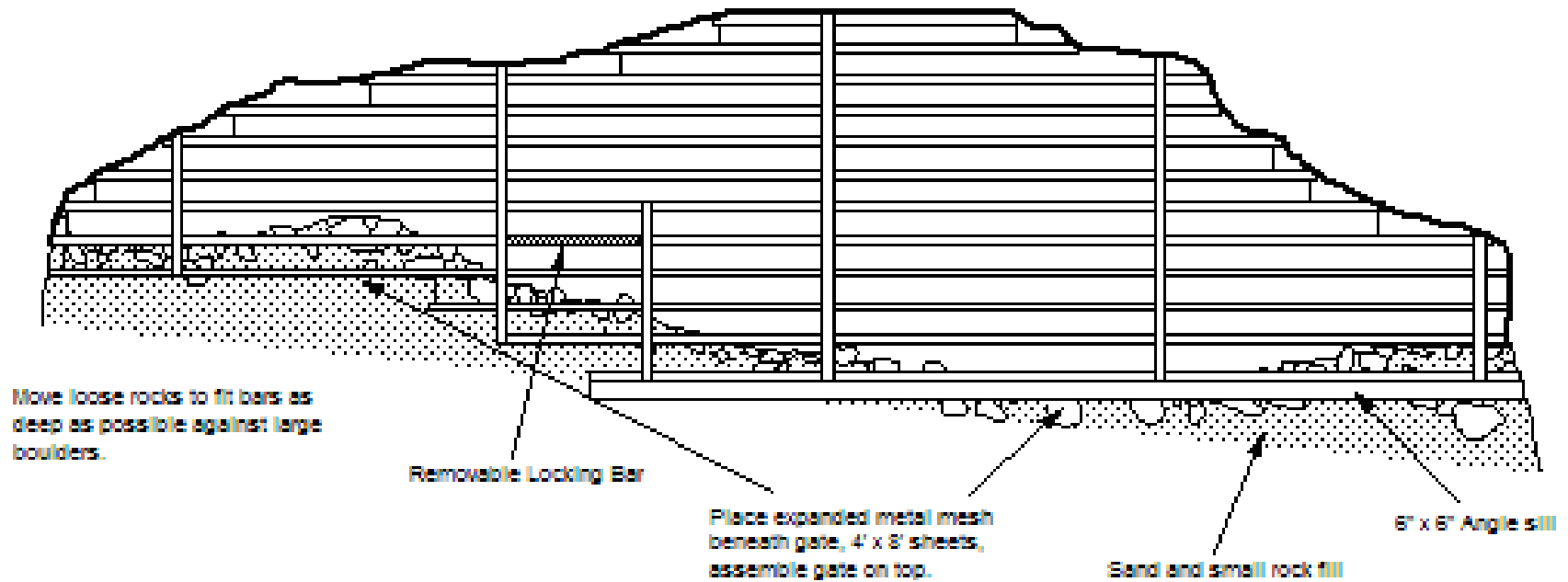

0 4 8 12 Feet