

002611

THE LIG
DEPARTMENT OF CONSERVATION
& LAND MANAGEMENT
WESTERN AUSTRALIA



002611

EAST PERTH CEMETERY:
RESTING PLACE OF WESTERN AUSTRALIAN PIONEERS

by

Dr. James A. Richardson (R.W.A.H.S.)

and

David Davies

(Department of Conservation & Land Management)

Based on Surveys 1983-1986 for the
Royal Western Australian Historical Society, Inc.

Perth, W.A.

May 1986

PLATES

Plate & Page No.

1	Slabs: Basic types
2-4	Oblong, Modified and Miscellaneous slabs
5-7	Peaked Slabs etc.
8	Anthropomorphic Slabs
9-12	Gothic Slabs
13-16	Celtic Crosses etc.
17-19	Crosses on Slabs
20-21	Miscellaneous Crosses
22	Shields
23-27	Miscellaneous
28-30	Calligraphy
31-32	Wrought-iron Fencing
33-35	Ornamental Slabs
36-37	Chest, Scroll etc.
38	Symbols & Calligraphy
39	Wrought-iron Fencing
40-46	Calligraphy and Decor
47-66	Miscellaneous Slabs
67	Norman Slabs: Popular designs
68	Gothic Slabs: Popular designs
69-72	Miscellaneous Slabs
73	Peaked Slabs: Popular designs
74-80	Miscellaneous Slabs
81	Script; Chest; Slab

PLATES:

<u>Plate</u>	<u>Type</u>	<u>Site</u>	<u>Name</u>
1	Miscellaneous slabs and crosses		
2	13	5-28	Letch; French
	13	52-672	Livingstone
	76	34-396	J.G. Austin, Esq.
	66	34-399; 32-353	De Burgh; Hillman
	21	36-431	Keeshan
	109	46-605	Glass
	194	27-244	Graham
	71	32-367	Law; Cresswell
	46	24-204	Scanlan
3	81	36-444	Padbury
	9	-	-
	80	35-428	Summerland
	80A	6-30	Dyer
	87	38-472	Waterman
	76	34-396	Austin
4	50	27-240	McNee
	5	10-54	Bennett
	133	19-131	Barron
	28	16-103	Buften
	64	31-325	Pakenham
	68	32-355	W.H. Leeder
	69	32-355	Leeder (footstone)
5	53	35-415	Oliver
	109	46-605	Glass
6	70	34-400	Goulston
	42	22-176	Connor
	111	46-614	Kate Bailey
	110	46-608	Cadden
	19	5-24	Clulow
	29	49-652	Jeffery
	90	40-492	Smith
	128	61-770	Huggins
	79	35-423	Trigg
	6	49-651	Foot
	6A	9-45	Read
7	15	27-222	Finlayson
	15	7-37	Jackaman
	40	28-261	Barratt-Lennard
	17	10-48	Stone
		10-53	Campbell
	53	28-279	Symmons
	66	34-399	De Burgh
	6	17-107	Mead

<u>Plate</u>	<u>Type</u>	<u>Site</u>	<u>Name</u>
8	116	48-644	Throssell
	109	46-605	Glass
	63	31-321	Horan; Guinness
	70	30-392	Dunmall
	74		Smith
	106	45-591	Brooking; Clay
		54-685	McMullin
		54-684	Nicholls
9		15-100	Brown
	55	21-271	McBride
	8	19-140	Read
	141	28-265	Parker
	26	14-58	Flynn
	118/161	50-656	Morris 118 Slab; 161 cross
	65	30-299	Taylor
10	9	43-551A	Speed
	55	45-595	Pusey
	122	55-693	Avery
	183	34-384	Elizabeth Smith
	93	40-501	Cresswell
11	126	60-752	Turner
	108	46-604	Moroney; Murphy
	8	45-583	Murphy
	Res 24	13-85	Hama
	122	55-693	Avery
	20	14-91	Man Wada
	114	47-627	Adams
	73	33-379	Reece
12	23	23-303	Brennan
	(decorated arch)		
	48	25-211	McMahon
	43	27-234	James
	8	28-253	O'Keefe
	8	3-10	Edwards
	23	13-83	McCann
	168	19-137	Fein
13	148	30-306	Anderson
	98	41-523	McElhatton
	119	51-664	Purcell
	92	40-498	Wilkinson
	113	21-163	Brown
14	170	40-515	Fraser
	113A	2-6	Whelan
		56-706	Hill
	41	22-173	Ryan
	169	27-224	Craig
	96	30-300	Finnerty

<u>Plate</u>	<u>Type</u>	<u>Site</u>	<u>Name</u>	
15	41	-	-	
	119	51-664	Purcell	
	49	27-238	Martyn	
	174 (Res 30)	40A-507	Tomlinson	
	167	47-622	Nowland	
16	30	12-67	Stoneman	
	139	20-149	Sellenger	
	145	30-289	Hayes	
	146	30-294	Wheeler	
	56	29-286	Ffarrington; Longbottom	
	17	62	30-320B	Sholl
151		49-466	Murphy	
117		49-648	Lambert	
115		48-638	O'Connell	
175		46-603	Stewart	
158		46-610	Forbes	
18		176	44-578	Whitfield
		44	14-785	Ota
	97	34-386	Davey	
	129	62-775	Stone	
	89	39-489	Kaeshagen	
		36-433	Louise	
	58	30-298	England	
	97	34-385	Dalzell	
	91	40-493	Harris	
	10	-	-	
	19	38	21-161	Naughton
32		55-702	Young	
		7-38	Lawrence	
143		28-271	Little Eric	
88		14-87	Nancarrow	
		39-480	Harry	
57		29-287	Fenton C.E.	
20		39	21-163	Brown
	37	26-214	Claffey	
	61	30-317	Thomas M. Inst. C.E.	
	49	27-238	Martyn	
21	39	21-163	Brown	
	60	30-360	Ferguson	
	127	60-755	Wright	
	123	56-708	Schruth	
	163	55-701	Stewart	
	190	42-544	Clifford	

<u>Plate</u>	<u>Type</u>	<u>Site</u>	<u>Name</u>
22	31	18-126	Clay
	178	51A-668	Leslie
	112	19-145	Howard
	162	55-700	Peel
	124	29-784	Wolff
	140	20-152	Caporn
	121	52-671	Valentine
	120	51A-670	Amsberg
	134	19-144	H. Taylor
	135	19-144	J. Taylor
	23	77	35-409
164		57-717	Jacoby
137		18-125	Inez
159		47-626	Baker
24	176	26-213	Claffey
	184	57-718	Blythe
	123	56-708	Schruth
	127	60-755	Wright
	35	19-143 22-176	Hoyle O'Connor
25		15-92	Tiddy
		46-604	Moroney
		47A-780	Connell
	182	31-324	Robinson
		46-603 20-151	Stewart Clarkson; Key
26	180	56-710	Meares
	127	60-755	Wright
		30-310	Ranford
		1-4	Hillas
27	161	50-656	Morris
		49-648	Lambert
		12-68	Schildt
		30-310	Ranford
		53A-677	Mann
		49-646	Murphy
		24-210	Boladeras
		22-303 24-211	Dearden McMahon
28		36-460	Smith
		30-297	Garwood
		36-454	Stone
		30-300	Finnerty
		21-161	Naughton

<u>Plate</u>	<u>Type</u>	<u>Site</u>	<u>Name</u>
29		47-630 44-580 42-541 27-219 20-148 35-418 39-486	Hutchinson Game Lillis Dickson Regan Spencer Hoyne
30	183	35-401 34-384	McArdle Smith
31		18-126 36-461 30-297	Clay Morrison Garwood
32		13-75 13-76	Monger Summers; Howlett
33	23 8 136 138	44-582 36-461 17-108 13-73 20-148	Grigson Morrison Stokes Wood Regan
34	103 1 (Decorated) 165 47	58-730 44-582 47A-781 9-43	Sassanowsky Grigson Tobin Gardner
35	107 78 144	45-597 35-410 28-275 15-100	Milford Minson Wittencoom Brown
36	22 17	15-94 10-48	Shenton Stone
37		27-226	Maclagan
38	23	36-434 30-310 35-407 43-560	Fletcher Ranford Bullen Urquhart
39		36-457	Mitchell; Churchyard
40		32-362 43-561	Sutherland White
41		46-612 45-595	Wylde Pusey

<u>Plate</u>	<u>Type</u>	<u>Site</u>	<u>Name</u>
42		43-566 44-572	Darch Burnside
43		38-466 47A-783 30-290 31-322	Kyle Gray McCourt Naughton
44	63	31-321	Horan; McGuinness
45		30-311	Burt
46		30-304B	Leake
47	170 149 147 2 54	40-515 35-407 31-336 12-66 29-278	Fraser Bullen Gregory Halliday Douglas
48	142 130 131 11 14 101 108	28-267 13-78 15-98 4-19 7-34 41-534 46-604	Hamersley Dyson Osborne Nesbit Guthrie Foster Moroney; Murphy
49	132 168 34 32 67 83 150	13-76 19-137 19-136 55-702 32-354 36-455 50-656	Summers Fein Joseph Young Leeder Knight Kelly
50	153 154 155 156 158 157 29 82 166	30-302 30-307 34-305 36-453 46-610 43-548 43-562 36-448D 47A-782	Cornelius Glyde Okely Louise Forbes McCoy Meloy Chipper Fennell
51	51 99 8/104 69 76 75	27-245 41-524 45-583 32-355 34-396 34-388	McManaway Murtha Murphy (104 panel) Leeder Austin Lewis

<u>Plate</u>	<u>Type</u>	<u>Site</u>	<u>Name</u>
51	36	35-425	Joyce
	24	-	-
	72	33-375	Hackett
52	52	28-260	Marfleet
	18	10-52A	Watson
	85	38-468	Costello
	95	40-504	Grieves
	84	38-467	Rotaheche; Barron
	16	-	-
	45	23-203	Dearden
	86	38-469	McKinley
	184	57-718	Blythe
53	94A	40-502	Parry (Headstone)
	94B	40-502	Parry (Footstone)
	125	57-523	Driffield
	59	30-309	MacPherson
	102	43-588	Stuart
	160	48-631	Lowe; Keevil
54		36-446	Chipper
	5	10-54	Bennett
		32-352	Taylor
	70	32-357	Picking
		36-441	Wimbridge
	7	19-141	Nelson
		57-719	Snell
	173	22-177	Schmidt
55	4	5-23	Dyer
	171	9-44	Glaskin
	172	10-51	Dewis
56	3	31-342	Middleton
	25	47-624)
		47-623) Hawley
		36-453	Golding; McMullen
	75	34-388	Lewis
	66	35-419	Durlacher
		41-523	McElhatton
	73	33-379	Reece
57	33	19-130	Buckingham
	105	45-588	Houston
		48-636	Curtain
	181	11-56	Drabble
		48-638	O'Connell
57	13	41-528	Elphick; Jackson
		57-665	Seery

<u>Plate</u>	<u>Type</u>	<u>Site</u>	<u>Name</u>	
58	6	8-42	Brittain	
	182	31-324	Robinson	
		43-565	Barron	
		40-493	Harris	
		43-556	Darch	
	179	12-69	Yoshida	
59	14	13-80A	Cooper	
	14	12-67A	Farmer	
	14A	13-77	Bell	
	14	16-105	Wright	
	182	30-290	Mary McCourt	
	8	28-253	O'Keefe	
		27-223	Coutts	
60	14	43-567	Short	
		51-660	Reen	
	91	40-493	Harris	
		9-786	Crisp; D'Arcy	
		8-41	Roy W.W.)	
	33/62	39-481	Dromey)	
	39A-482	Mary Younge)		
62	176	19-147	Takahashi	
	15	21-164	Jennings	
	cf 27	21-169	Fewster	
	cf 47	22-178	Peace	
		22-175A	Quinlan	
61	15	3-8	Foster	
	47	9-43	Gardner	
		7-38B	Lawrance	
	185	11-59	Hutton	
		18-116	Watson	
	15	10-47	Law	
		15-97	Laurance	
		19-135A	Cohen	
	(cf 112)	186	19-135B	Salomons
		11	19-138	Biddle
	36	19-146	Eaton	
63	23	22-180	Hiles	
	34	22-190	Shearer	
	14	27-221	Baillie	
	187	22-189	Dimant	
		32-374	Whitehead	
		32-366A	Hillman	
		22-183	Murdoch	

Broken crosses

<u>Plate</u>	<u>Type</u>	<u>Site</u>	<u>Name</u>
64	188	34-383	Byron
	66	35-420	Sweeting
	Res 9	39-486	Hoyne
	Res 80	36-459	Smith
		38-471	Hutchison
	14	39A-434	Richards
	189	40A-507	Tomlinson
65	26	46-616	Joyce
	117	49-648	Lambert
	23	53-677	Mann
		56-686	Maitland
	27	55-696	Duncan
	14A	59-740	Brown
		46-603	Stewart
66		56-686	Maitland
		13-79	Mews
	37	13-80B	Kross
	23	13-83A	McCann
	27	13-83B	Waldock
	52/53	15-100	Brown
	191	17-113	Schloss
	192	42-545	Willis
67	Norman		
68	Gothic		
69		42-546	Smith
	192	38-473	Marsengo
	Ledger	39-490	Broderick
		45-587	Unknown
	13	43-563	Gwynne
		48-640	Aubyn
	26	48-636	Curtain
		49-645	Kelly
	199	44-566	Sullivan
70		58-733	Gillett
	8	61-766	Pritchard
		61-767	Dixon
	8	62-766	Wilkins
	176	62-778	Lamb
	8	44-582	Grigson
	13	43-563	Gwynne
	1/193	41-535	Cockram
	1	11-57	Rider
71		44-581	Sowden
	1	12-70	Haines
	8	13-71	Angove
	Res 17	13-78	Dyson
	Res 52	13-82	Plant

<u>Plate</u>	<u>Type</u>	<u>Site</u>	<u>Name</u>
72	14A	15-92	Tiddy
	8	17-108	Stokes, Linthorne
	18	18-124	Cornish
	1	21-160	Hughes
	36/195	22-182	Anderson
	196	22-195	Pringle
73	Peaked Slabs		
74		23-200	Murphy
		23-201	Hicks
		29-281	Fallon
	14	24-205	O'Dea
		27-229	Woolley
		30-291	Sullivan
		30-315	Barnfield
75	8/95	30-292	Mulhall
	197	32-352	Taylor
	198	10-53	Campbell
		32-360B	Jones
		23-198	Moloney
	Res 65	28-254	Lee
76	18	36-436	Oliver
		36-442	Haysom
	26	36-440	Wear
	52/23	36-461A	Morrison
	36	40-510	Stone
		42-544	Clifford
	1	39A-483	McGuinness
77	8	41-522	McGrath
	105	43-575	Darley
	8	45-592	Sutton
	200	43-578	Whitfield
	1	46-607	Mansfield
	8	47A-783	Gray
	52/23	45-594	Herdsmen
78	9	46-615	James
	Res 192	48-631	Low
		46-618	Smith
		48-641	Peate
		47-619	Fox
		50-655	Ryan
79		51A-622	Boyle
		53-675	Lackey
	6	40A-509	Wheat
	(Tapered)		
	23/101	55-691	Lloyd

<u>Plate</u>	<u>Type</u>	<u>Site</u>	<u>Name</u>
79	6	56-703	Koe
	8	60-756	Eliot
	180	56-710	Meares
80	1	55-698	Daniels
		22-173	Ryan
		32-354	Leeder
81		12-62	Neelands
		32-370	Wells, Badcock
		55-688	Steele

PHOTOGRAPHS

Spool 1 by Ranger David Davies: Sept.-Nov. 1983

Page No.

1	27-234	Emma Catchlove JAMES	82
2	36-451	Abraham MORGAN	"
3	36-452	Sophia & Thomas HESTER	"
4	36-457	MITCHELL	"
5	36-457	CHURCHYARD	83
6	35-418	SPENCER	"
7	35-410	MINSON	"
8	35-407	BULLEN	"
9	35-405	SPRATT	84
10	23-202	BRENNAN	"
11	23-203	DEARDEN	"
13	21-167	HELMICH	85
14	22-195	PRINGLE	"
15	27-138	MARTYN	"
16	28-267	HAMERSLEY	"
17	30-295	CARMICHAEL	86
18	27-220	DICKSON	"
19	27-222	FINLAYSON	"
20	26-213	CLAFFEY	"
	26-214	CLAFFEY	

Spool A by J.A. Richardson: Sept.-Nov. 1983

A 0	28-258	SAUNDERS	87
A 1	28-258	Detail Rustic cross.	"
A 2	20-148	REGAN	"
A 3	21-163	BROWN	"
A 4	21-161	NAUGHTON	88
A 5	20-150	SMITH	"
A 6	21-165	FARRELLY; NUNAN	"
A 7	3-11	BUNNING	"
A 8	4-18	NESBIT	89
A 9	5-24	CLULOW & DYER	"
A10	5-26	HYMUS; BIRCH	"
A11	6-31	BIRCH (H.S. B)	"
A12	8-40	MANNING	90
A13	12-63	BARRATT	"
A14	12-67	INKPEN; FARMER; STONEMAN	"
A15	13-71	ANGOVE	"
A16	13-79	MEWS	91
A17	13-81	CASS; KRUGER	"
A28	13-83	McCANN (H.S. 13)	"
A19	13-85	HAMA	"
A20	12-70	HAINES	92
A21	19-142	MONGER (Main vault)	"
A22	19-142	" "	"
A23	15-98	OSBORNE	"
A24	15-99	WELLS	93

			<u>Page No.</u>
A25	15-101	GLOVER	93
A26	16-106	PALMER	"
A27	17-108	STOKES	"
A28	18-119	KOTT (Hebrew Inscription)	94
A29	17-110	STEVENS	"
A30	17-112	ARMSTRONG	"
A31	18-124	CORNISH	"
A32	19-143	HOYLE	95
A33	19-139	WANSBROUGH	"
A34	20-153	ELSEGOOD	"
A35	20-151	CLARKSON; KEY	"
A36	22-175	QUINLAN; CONNOR	96
A37	22-174	MURPHY	"

Spool B J.A. Richardson: 1983

B00	46-613	Sir COCKBURN CAMPBELL	97
B 1	44-577	FFARRINGTON	"
B 2	44-578	WHITFIELD	"
B 3	44-581	SOWDEN	"
B 4	43-563	GWYNNE	98
B 6	36-445	PANTER; GOLDWYER; HARDING; MAITLAND BROWN	"
B 7	36-446	CHIPPER	"
B 8	36-447	CHIPPER	"
B 9	36-448	CHIPPER	99
B10	36-454	STONE; KNIGHT	"
B11	36-457	CHURCHYARD; MITCHELL	"
B12	35-425	JOYCE	"
B13	35-412	SNOOK; WIGGLESWORTH	100
B14	35-411	TOWTON	"
B15	35-409	HALL	"
B16	35-407	BULLEN	"
B17	35-405	SPRATT	101
B18	34-384	SMITH	"
B19	38-468	Wm COSTELLO Jnr	"
B20	38-469	Patrick McKINLEY	"
B21	39-486	HOYNE	102
B22	39-485	KELLY	"
B23	39A-484	RICHARDS	"
B24	6-31	BIRCH (Altar)	"
B25	7-35	AH MONG	103
B26	9-44	GLASKIN	"
B27	10-51	DEWIS	"
B28	11-56	DRABBLE	"
B29	16-103	BUFTON	104
B30	28-254	LEE	"
B31	28-254	(Details)	"
B32	61-770	HUGGINS	"
B33	60-755	WRIGHT	105
B34	59-741	FAAHAN	"
B35	57-720	DUNCAN	"
B36	57-722	FOX; HARDING	"
B37	55-699	DENNY	106

Spool C J.A. Richardson: 1983

C00	23-200	MURPHY	107
C 0	23-199	KELLY	"
C 1	25-210	BOLADERAS	"
C 2	25-208	O'ROURKE	"
C 3	27-217	GUILFOYLE; CARR	108
C 4	27-226	MacLAGAN	"
C 5	27-234	JAMES	"
C 6	21-166	MacPHERSON	"
C 7	27-248; 27-249	GRANT; EDGAR	109
C 8	28-264	STABLES	"
C 9	28-266	STRICKLAND	"
C10	28-275	WITTENOOM	"
C11	38-471	HUTCHISON	110
C12		St Bartholemew's Church	"
C13	39-485	Patrick KELLY	"
C14	40-492	John SMITH	"
C15	40-501	CRESSWELL	111
C16	40-504	GRIEVES	"
C17	40-507	TOMLINSON	"
C18	36-454	STONE John Frederick	"
C19	41-535	COCKRAM	112
C20	43-559	HILLS	"
C20	43-559	HILLS; STUART	"
C21	41-525	GUILFOYLE	"
C22	47-622	NOWLAND	"
C23	61-766	PRITCHARD	113
C24	60-752	TURNER	"
C25	61-755	WRIGHT	"
C26	41-522	McGRATH	"
C27	32-349	CURRAN	114
C28	32-350	PRATT	"
C29	30-291	SULLIVAN	"
C30	28-255	LEEDER	"
C31	28-255	"	115
C32	28-258	SAUNDERS	"
C33	31-331	STONE	"
C34	32-354	Wm LEEDER	"
C35	32-374	WHITEHEAD	116
C36	32-364	GOOCH; CAMERON (Fencework)	"

MAPS

	<u>Scale</u>	<u>Page No.</u>
1. Perth Burial Ground, 1845, Anglican	1:240	118-119
2. East Perth Cemetery: Gravesites:	1:470 approx.	120-121
3. East Perth Cemetery: Possible Gravesites	1:470 approx.	122-123
4. Plan 5126, 2.6.1939 showing cemetery Lots	1:792 (1 inch ≡ 1 chain)	124-125
5. Perth Roll Plan, Sheet 6 (Part) Cemetery Hill & former approach road - Forrest Avenue Shows Lots E70 & E71 as Presbyterian sites	1:2500 approx.	126
6. City of Perth, Sheet 28.48 (West part)	1:1000	127

SLABS: BASIC STYLES

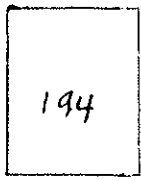

BASIC SLAB

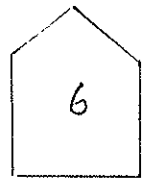

GABLED



STEPPED

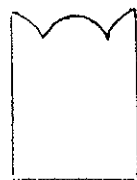

ANTHROPOMORPHIC

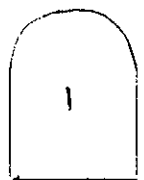

NORMAN

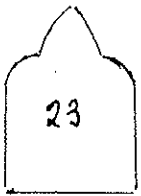

NORMAN/GOTHIC
"SHOULDERED GOTHIC"



GOthic

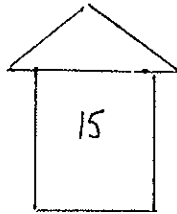

GABLE

CROSSES: BASIC STYLES

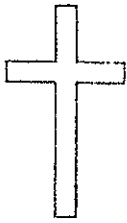

(d) Latin cross

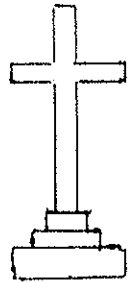

CALVARY
3 or 4 TIERED

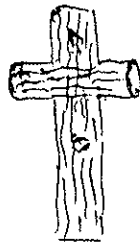

RUSTIC

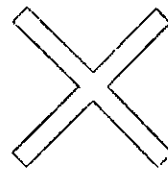

(b) Equilateral diagonal cross associated with St. Andrew.

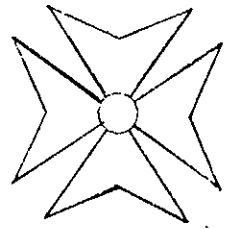

(g) Maltese cross.

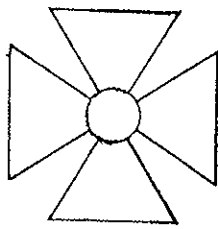

(f) Cross Patée.

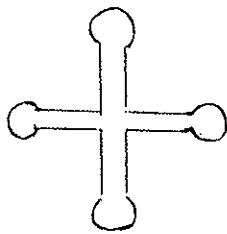

POMMÉE

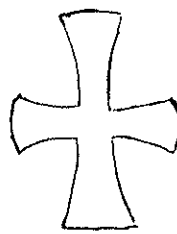

FORMÉE

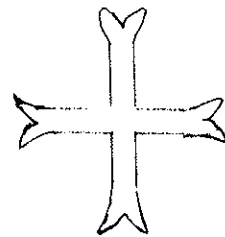

FOURCHÉE

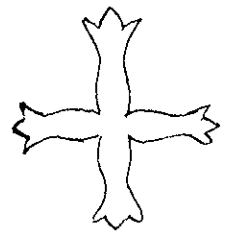

AVELLAN

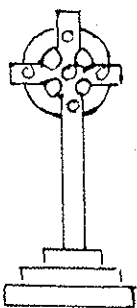

CELTIC

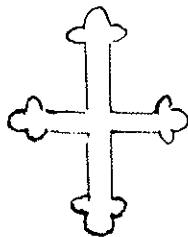

PATÉE

OR LONG SLABS

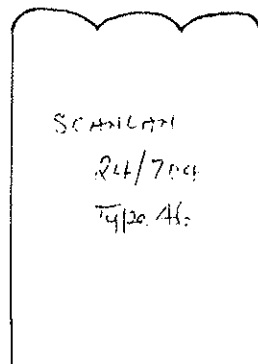
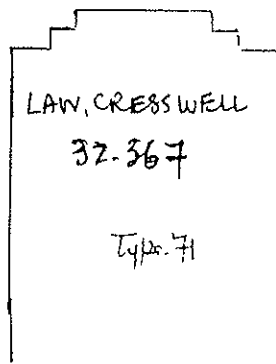
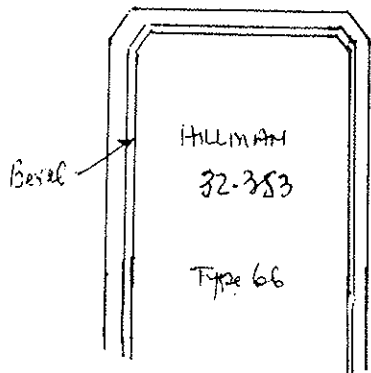
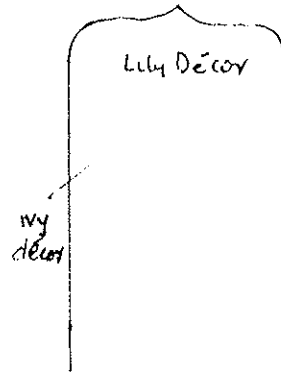
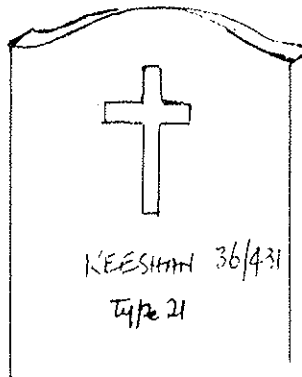
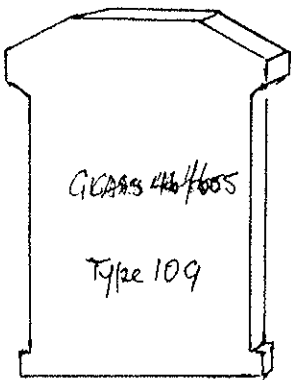
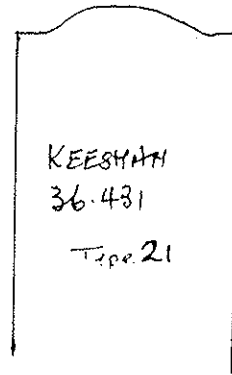
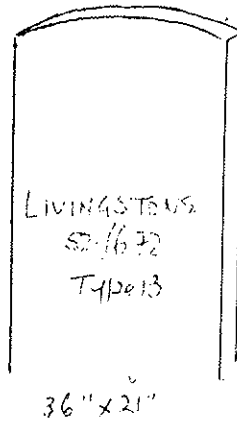
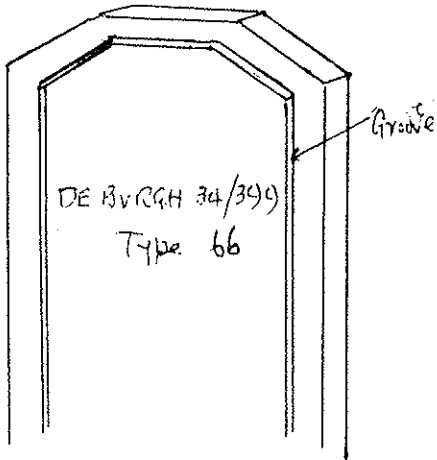
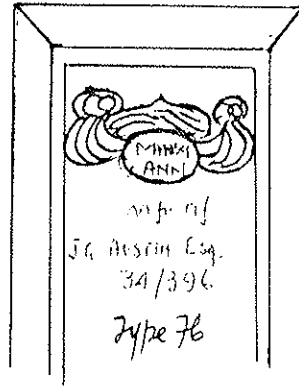
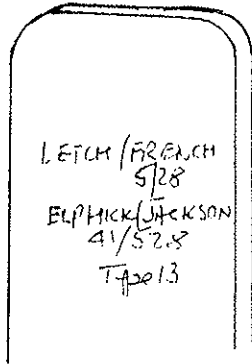
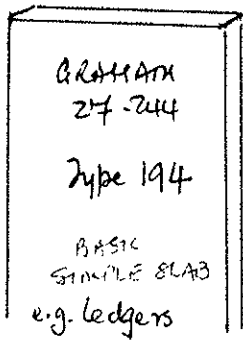
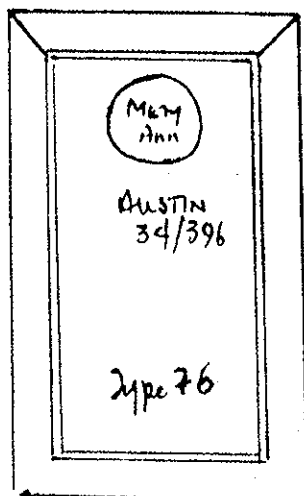
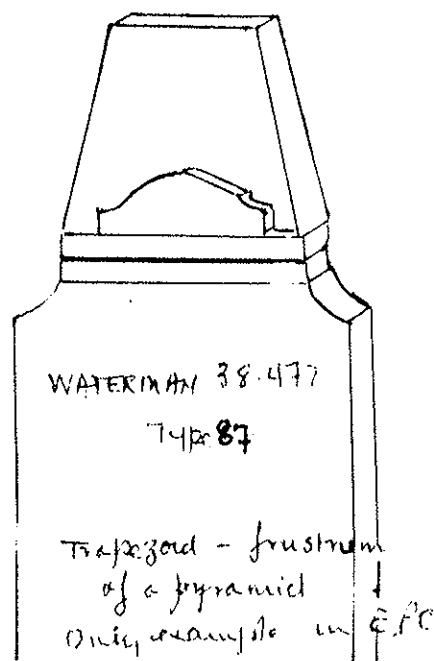
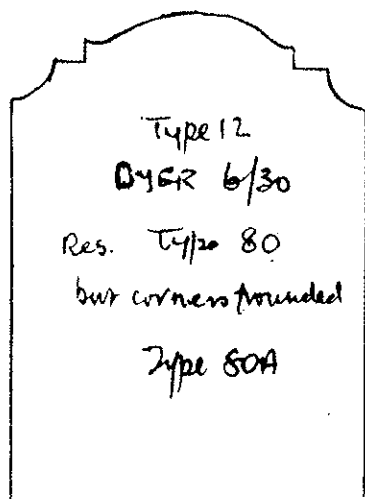
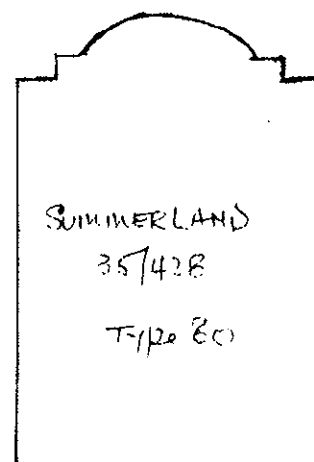
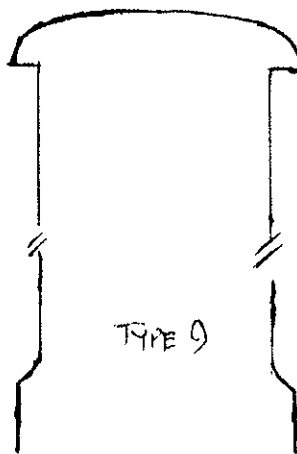
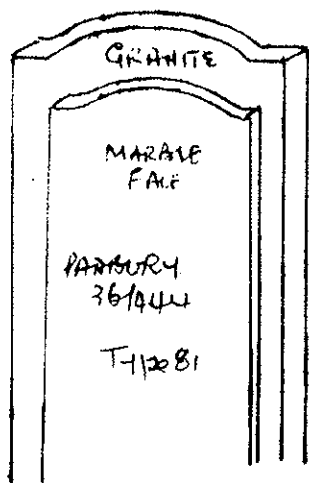

PLATE 2

MODIFIED SLABS



Cf Sutherland
32/362
Slab with Fleur
de lys in each
Corner

was ledger, now vertical

MISCELLANEOUS SLABS

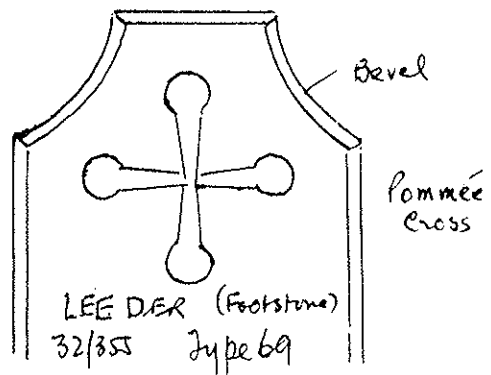
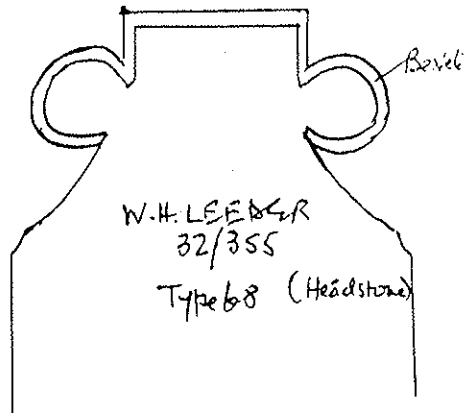
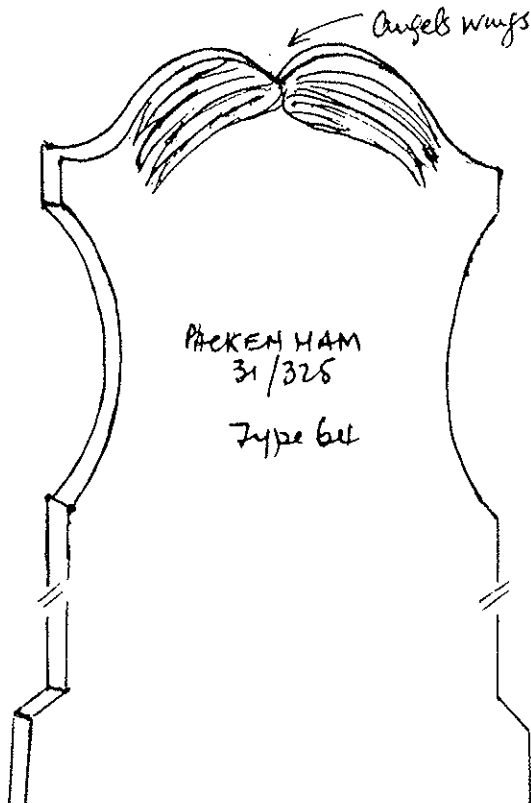
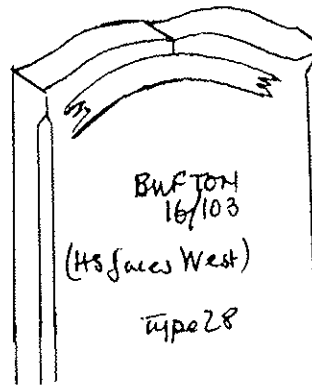
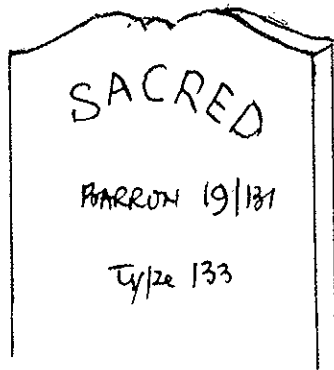
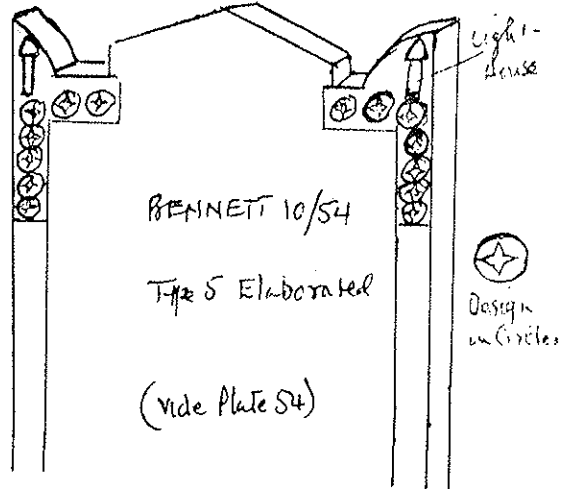
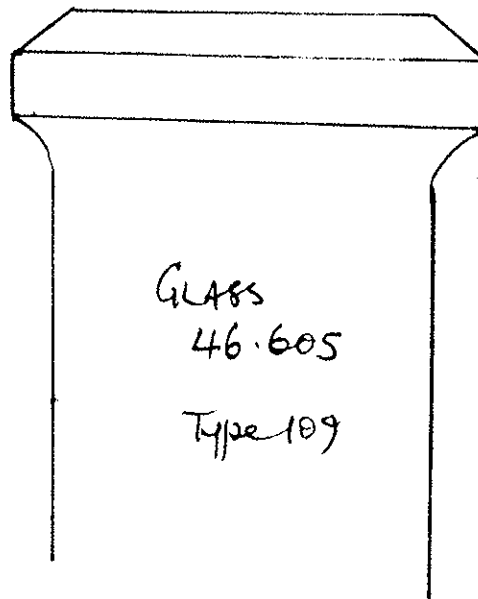
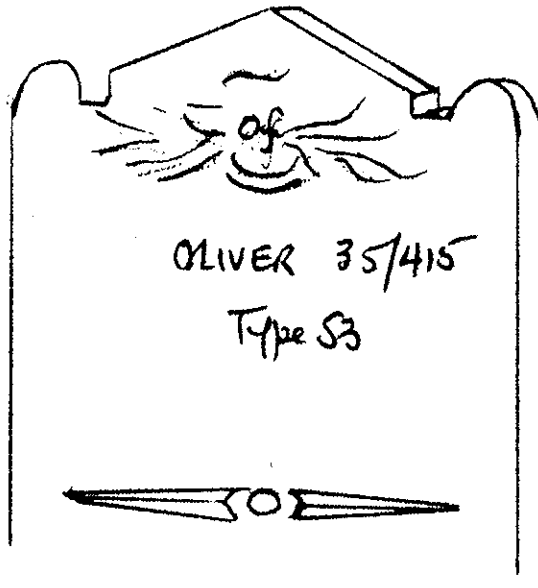
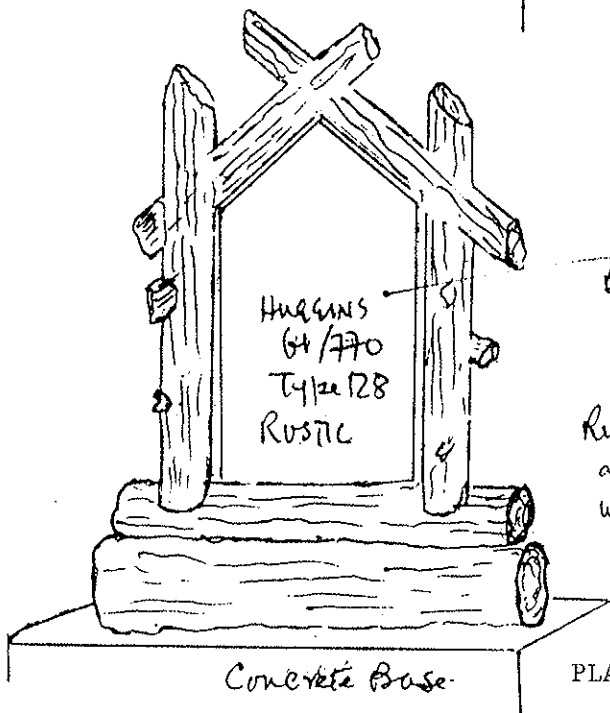
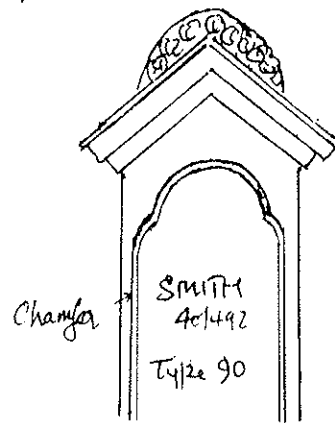
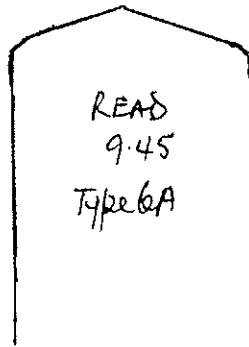
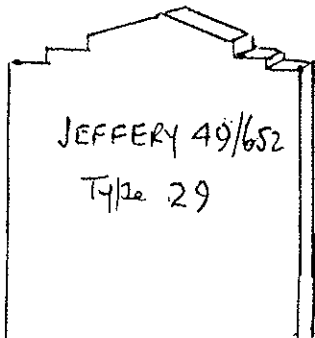
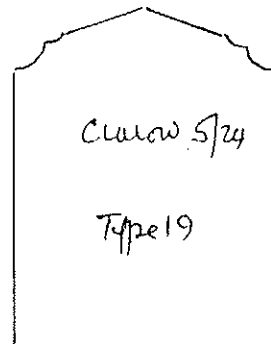
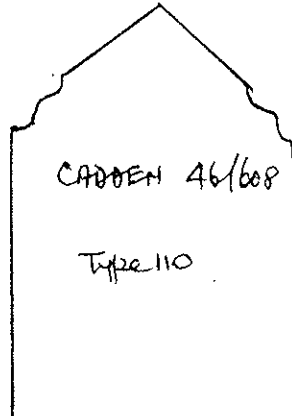
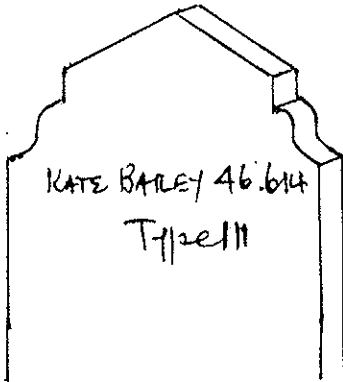
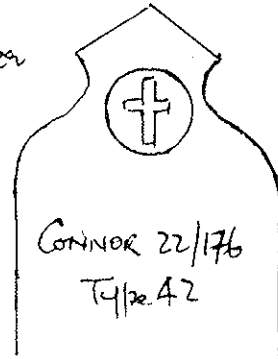
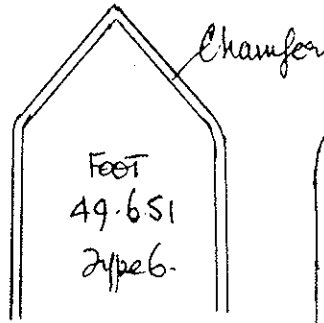
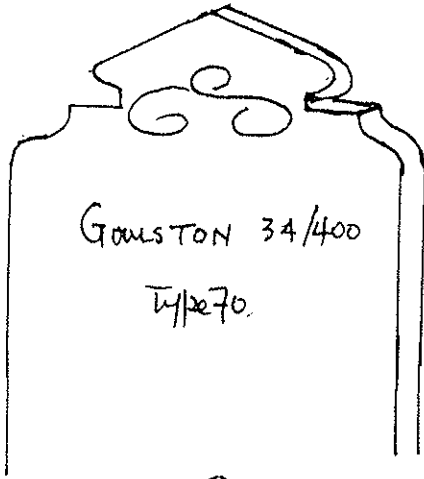

PLATE 4

PEAKED SLABS ETC



PEAKED SLABS



Bevelled
Polished
Marble
Slab

Rustic Archway
all carved
w/ knots etc,
marble



PLATE 6

PEAKED SLABS + MONUMENTS

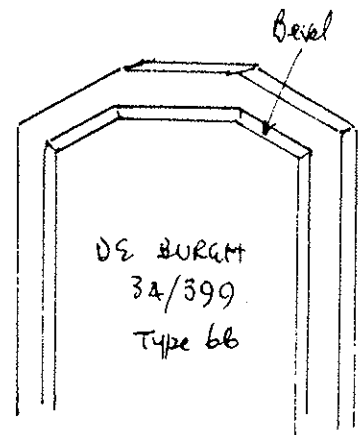
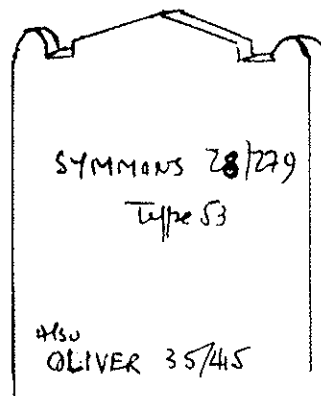
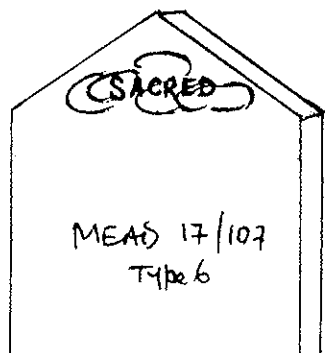
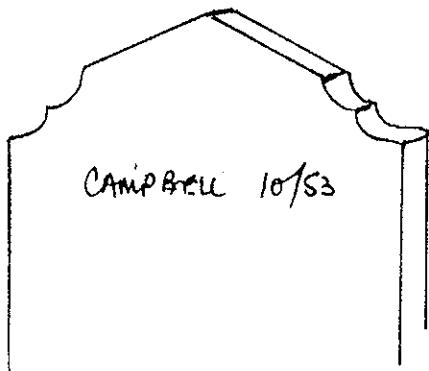
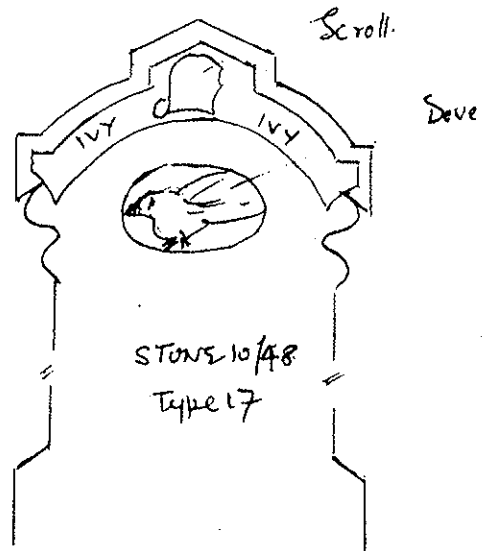
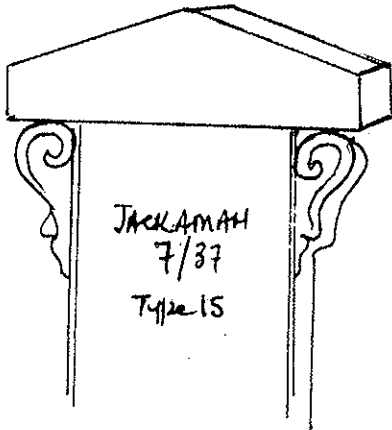
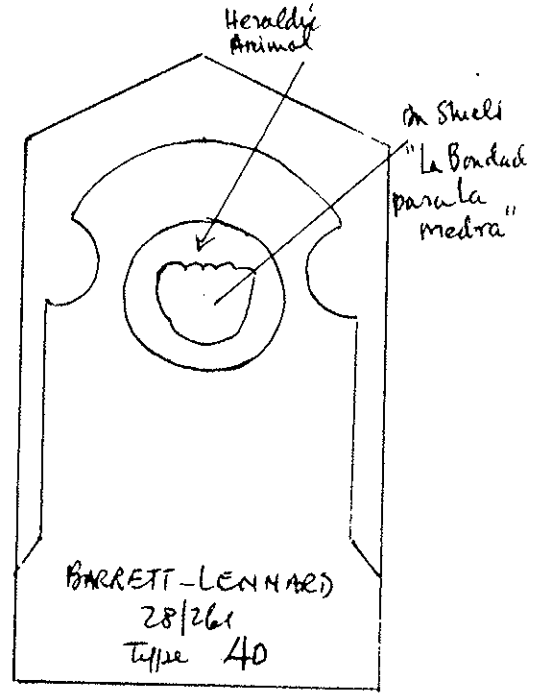
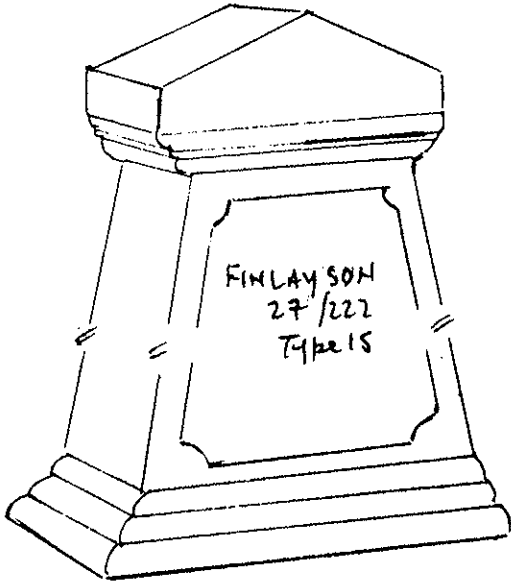
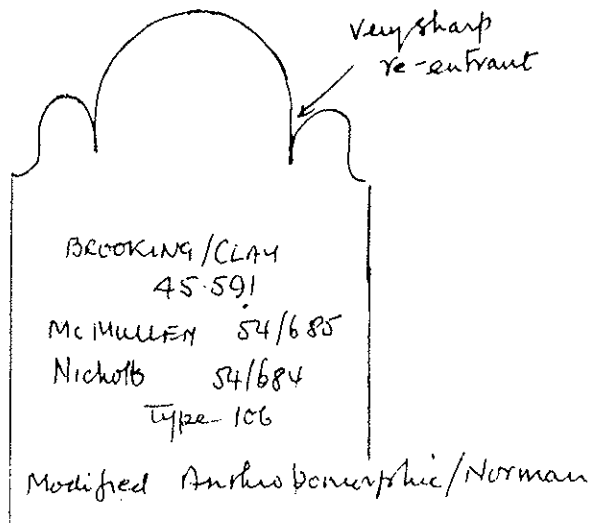
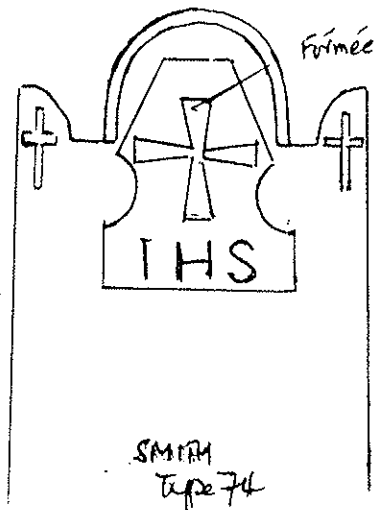
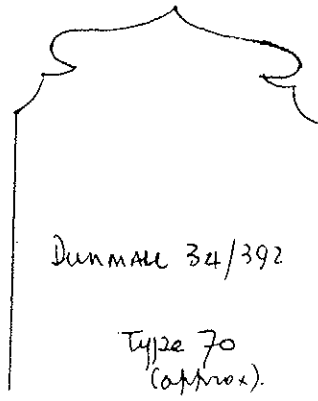
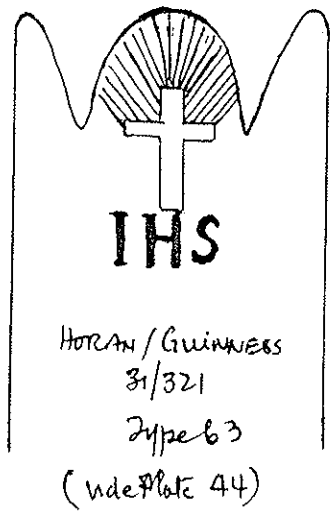
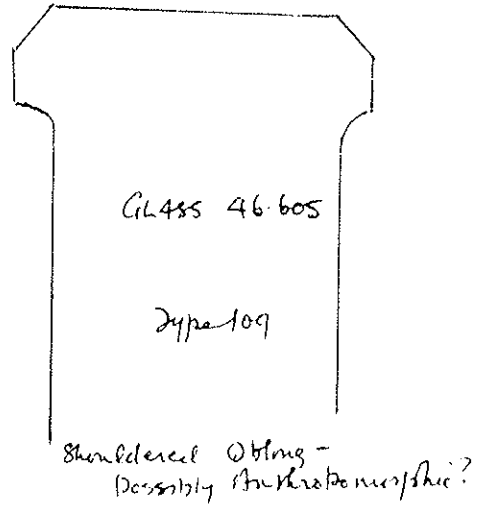
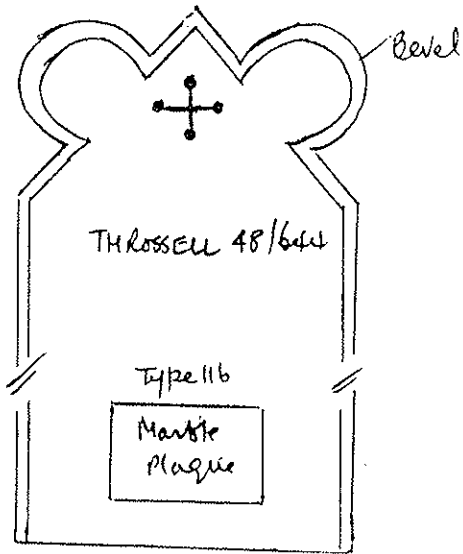
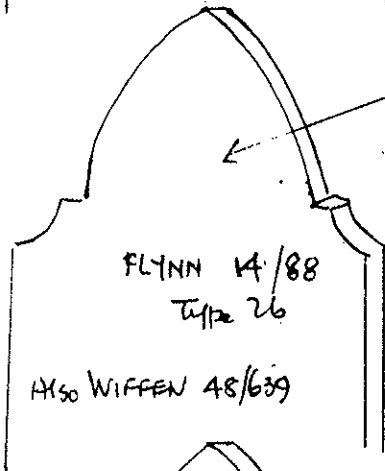
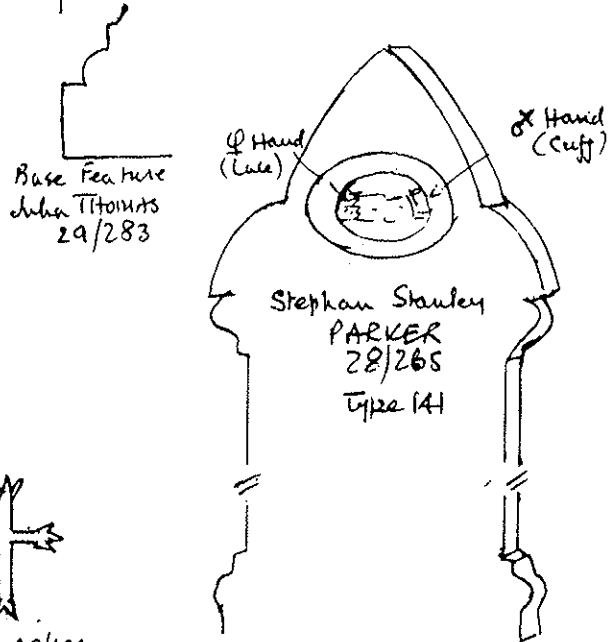
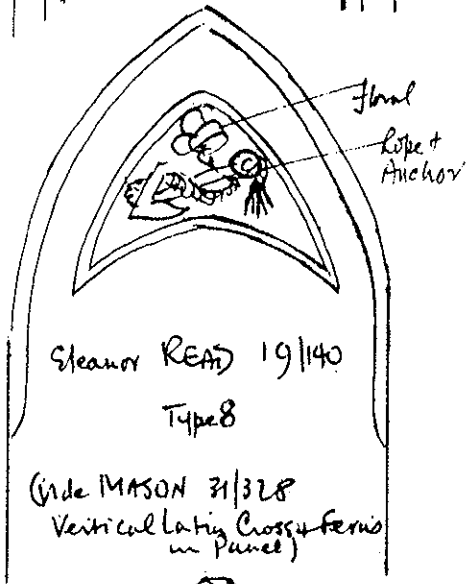
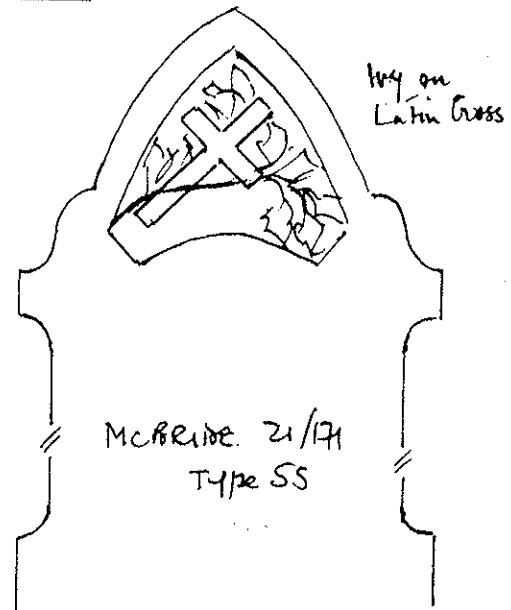
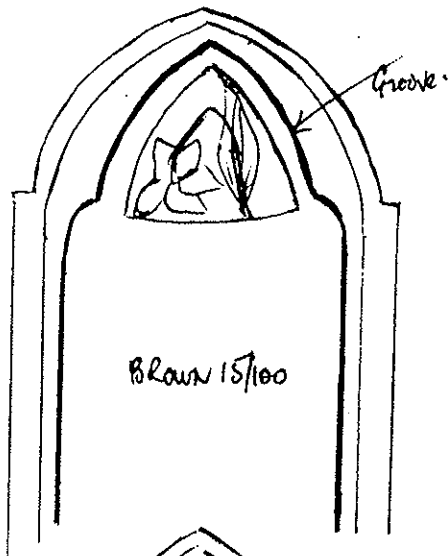

PLATE 7

ANTHROPOMORPHIC GLASS



GOthic



WIFFEN 48/639
has Avellan Cross
in panel

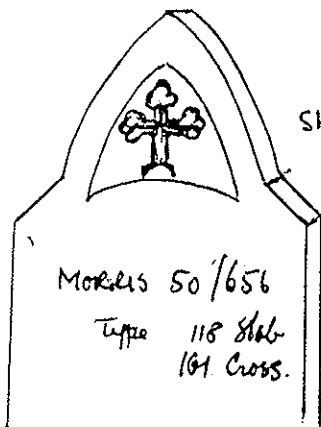
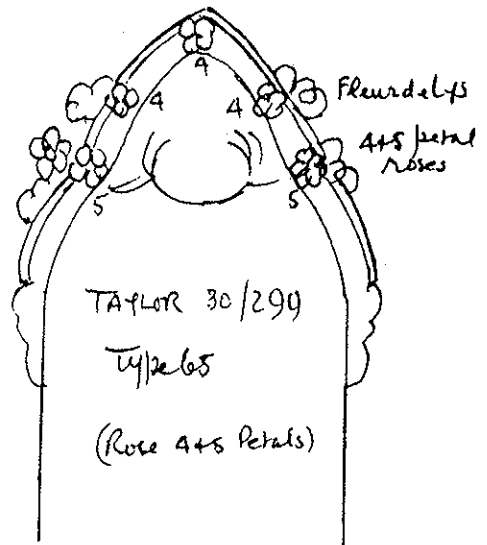

Shamrock
Cross



Alternate
form of Cross

GOTHIC ETC

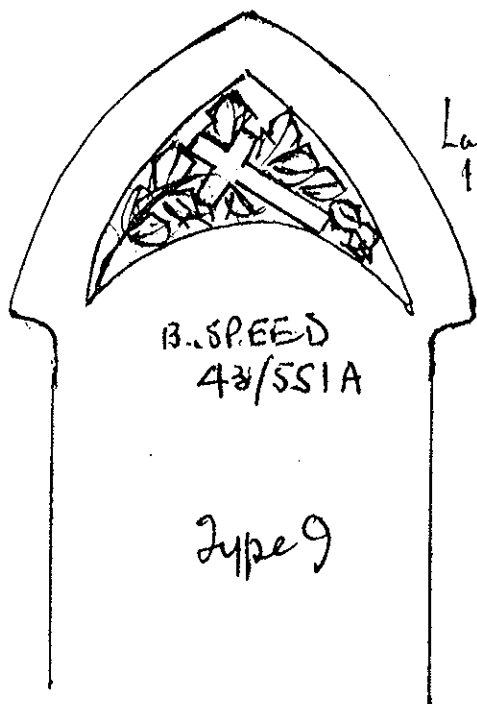

Latin Cross +
floral Decor

B. SPEED
43/551A

Type 9

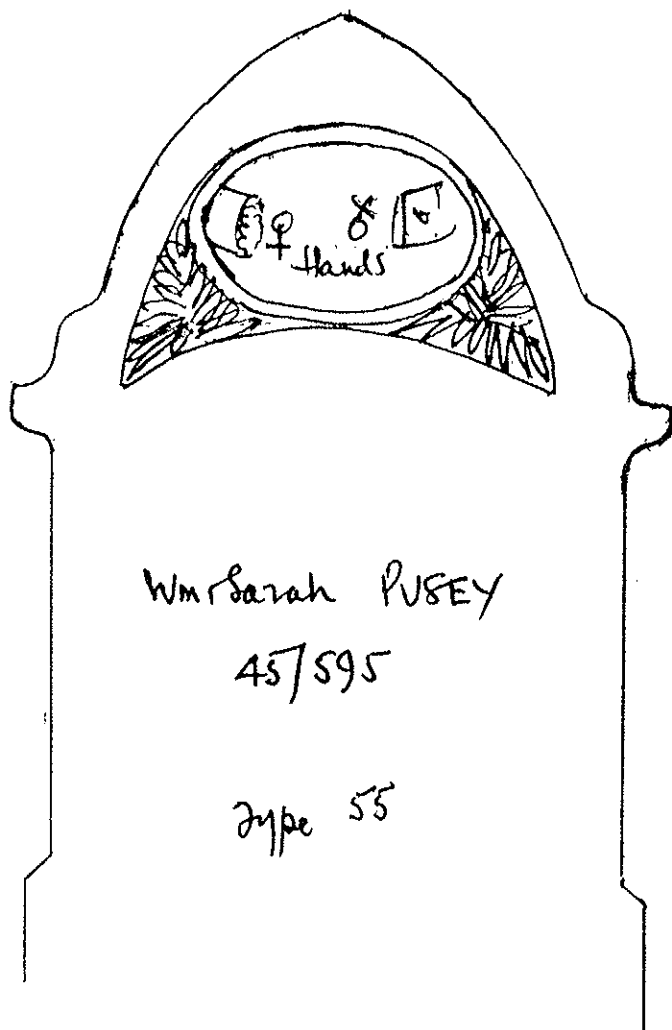

Wm Sarah PUSEY

45/595

Type 55

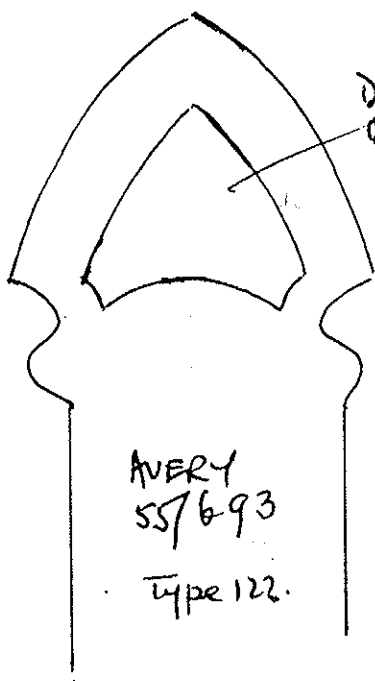

Dove +
olive
branch

AVERY
55/693

Type 122.

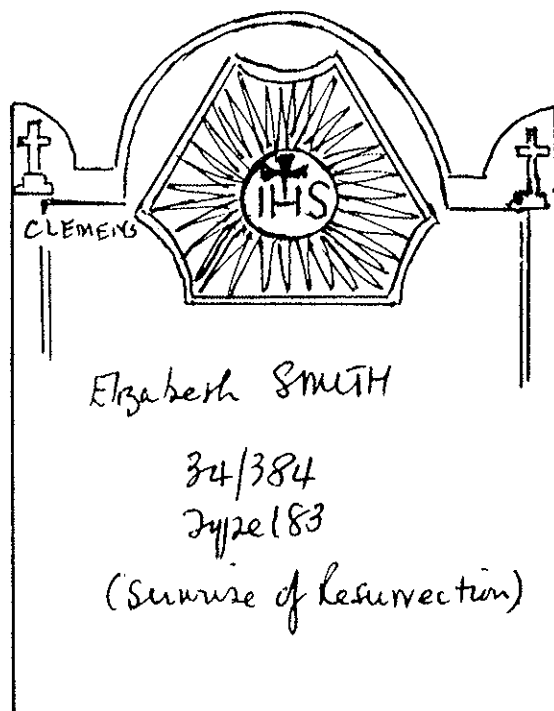

CLEMENS

Elizabeth SMITH

34/384

Type 183

(Sunrise of Resurrection)

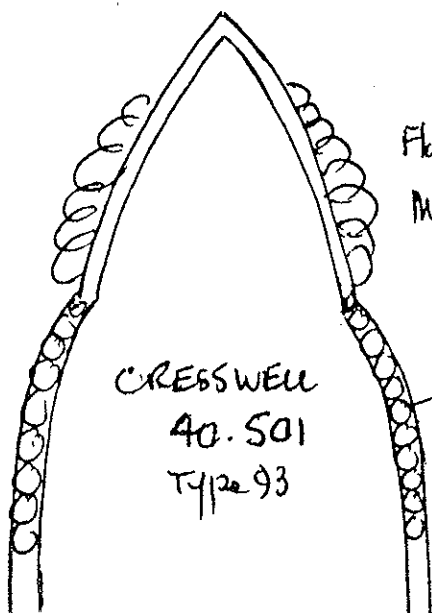

Floral Decor
Madonna
Lilies

CRESSWELL
40.501
Type 93

Rose Decor

GOthic ETC

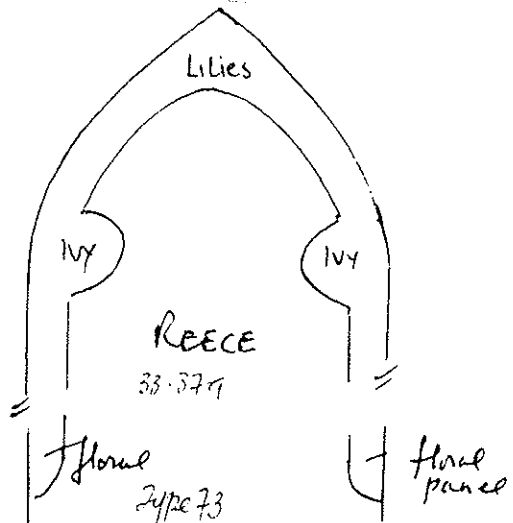
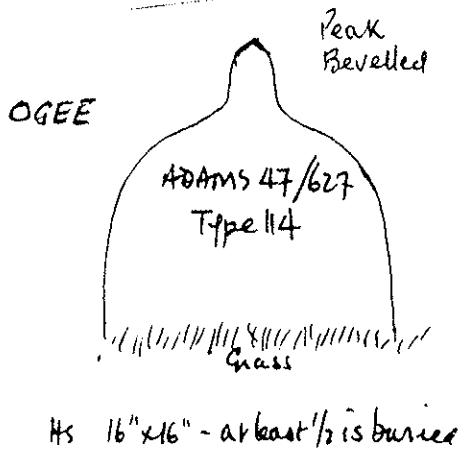
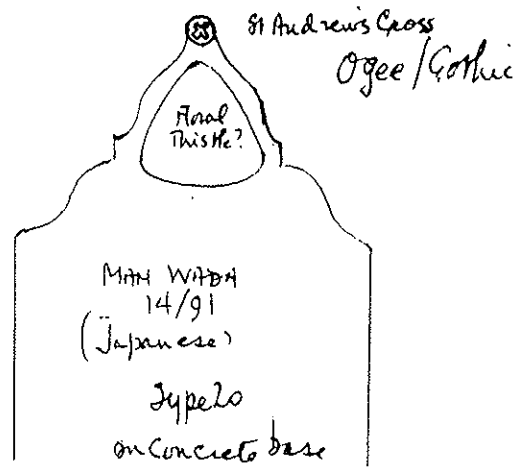
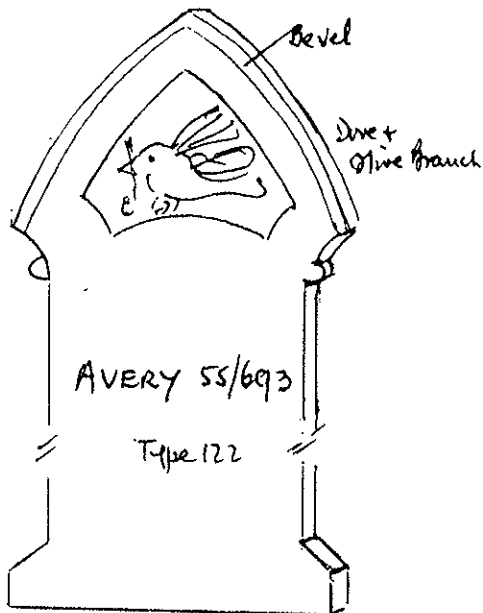
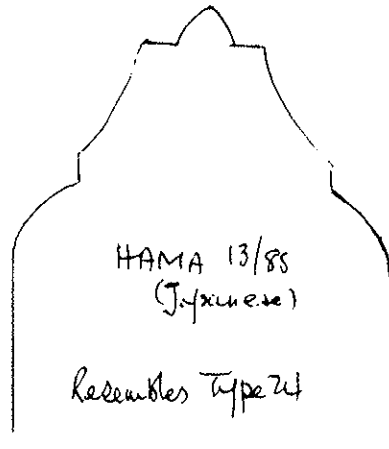
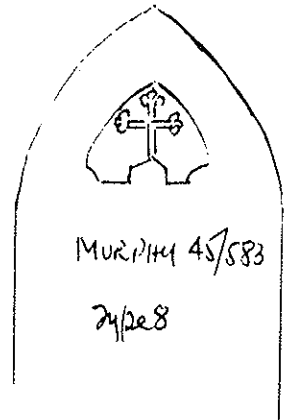
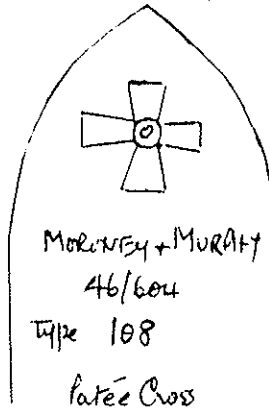
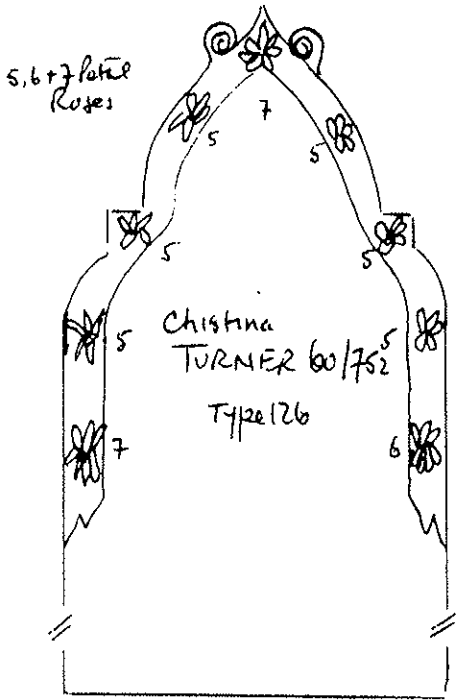
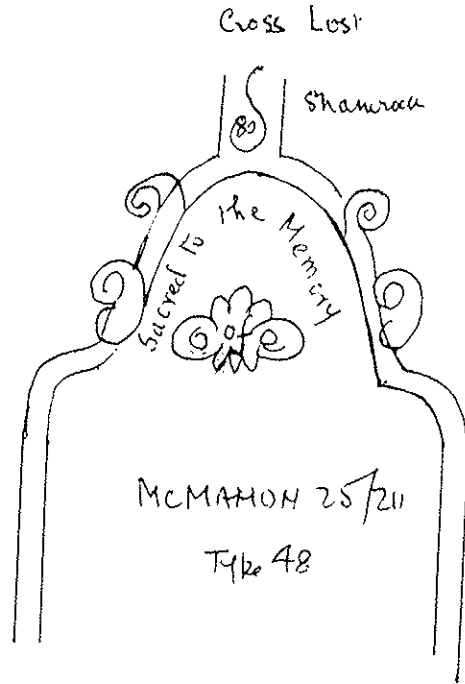

PLATE 11

GOTHIC



BRENNAN
23/202
Type 23
Decorated Arch



Cross Lost

Shamrock

Sacred to the Memory

MCMANON 25/211
Type 48

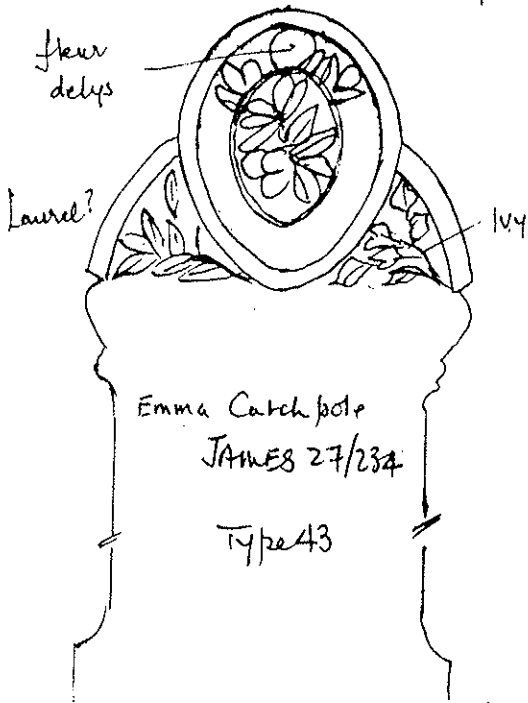

Flour
debris

Laurel?

144

Emma Catchpole
JAMES 27/234
Type 43

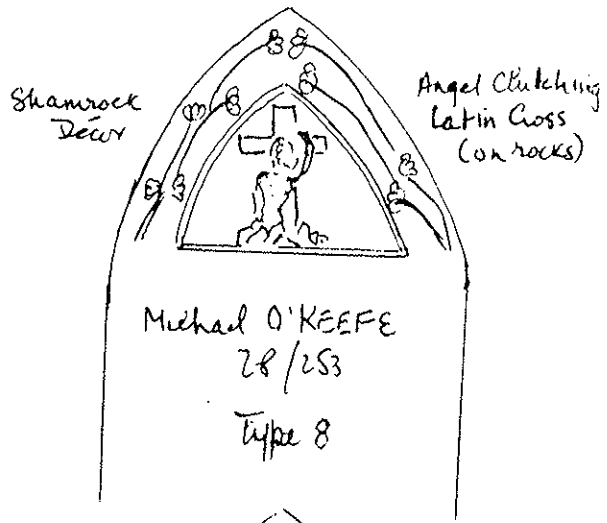

Shamrock
Decor

Angel Clutching
Latin Cross
(on rocks)

Michael O'KEEFE
28/253
Type 8

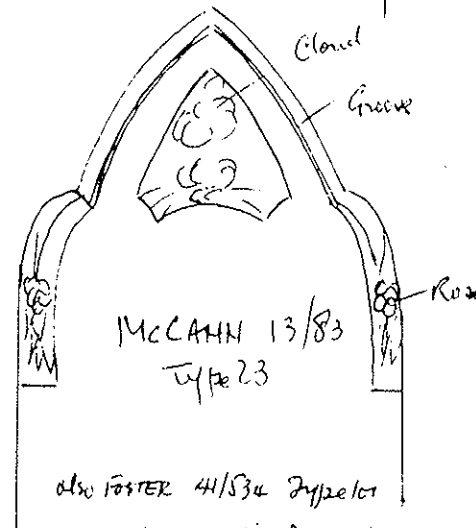

Cloud

Groove

Row

MCCANN 13/83
Type 23

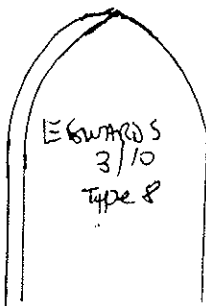

EDWARDS
3/10
Type 8

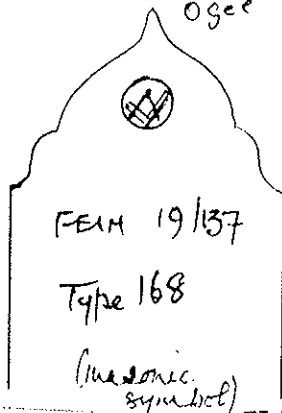

Ogee

FEIN 19/137
Type 168

(Masonic
symbol)

also FOSTER 41/534 Type 101
Has dove & olive branch
in panel

Resembles Brennan 23/202
but lacks ornamentation

CELTIC CROSSES

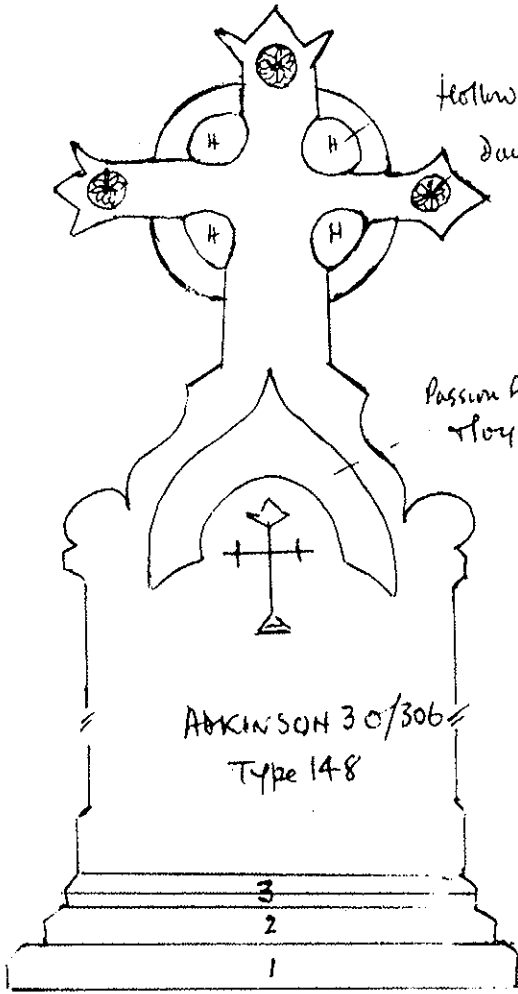

Hollow
daisy

Passion flowers
Flour Décor

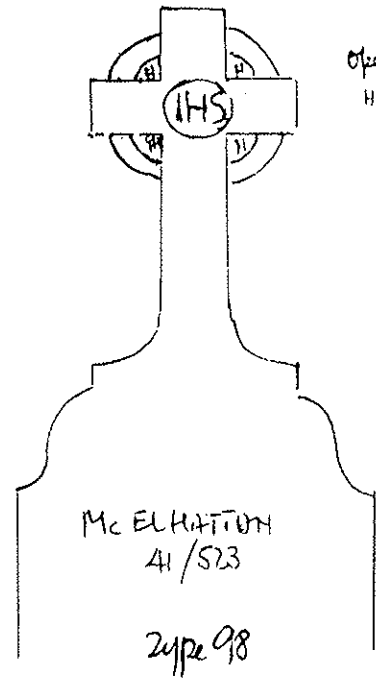

Open Cross
H = Hole

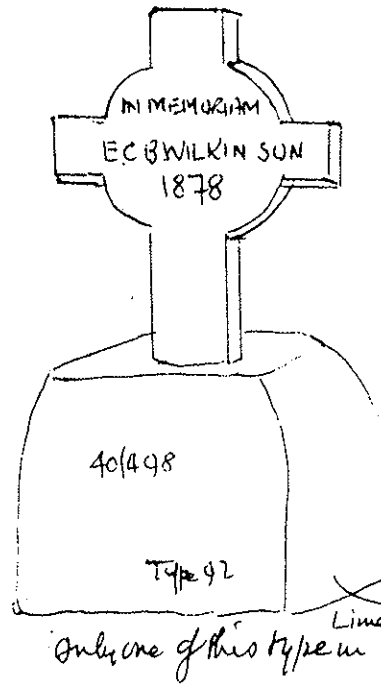

1/2 round
Limestone block

Only one of this type in E.P.C.

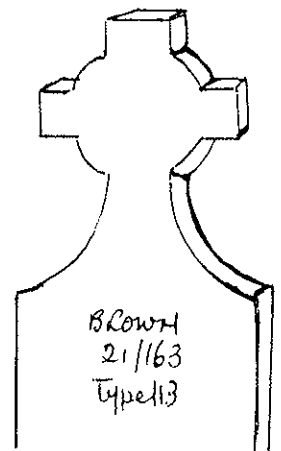
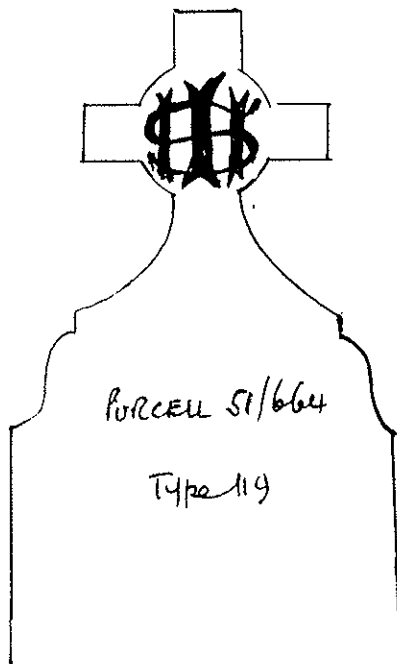

Solid
Cross

PLATE 13

CELTIC CROSSES

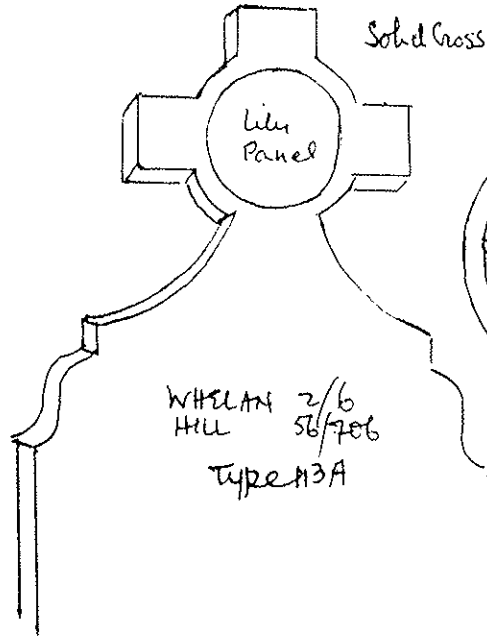
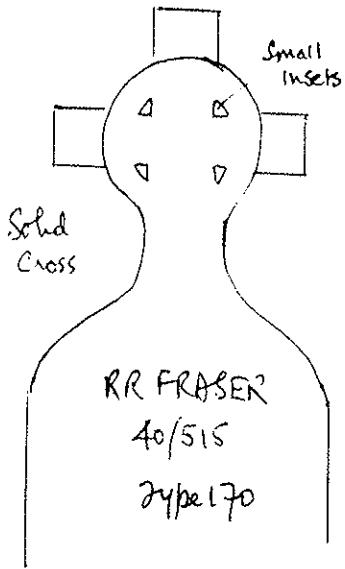

Lily Panel
cf WESS 39/488
URQUHART 43/560

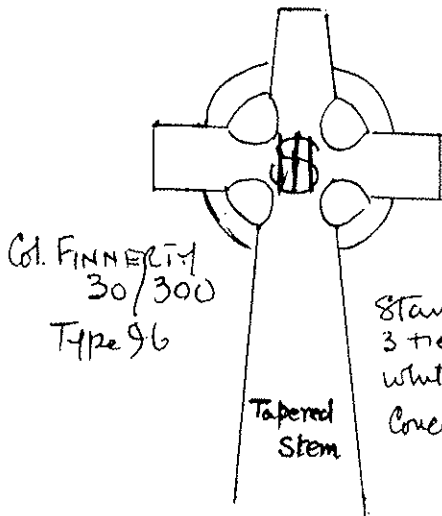
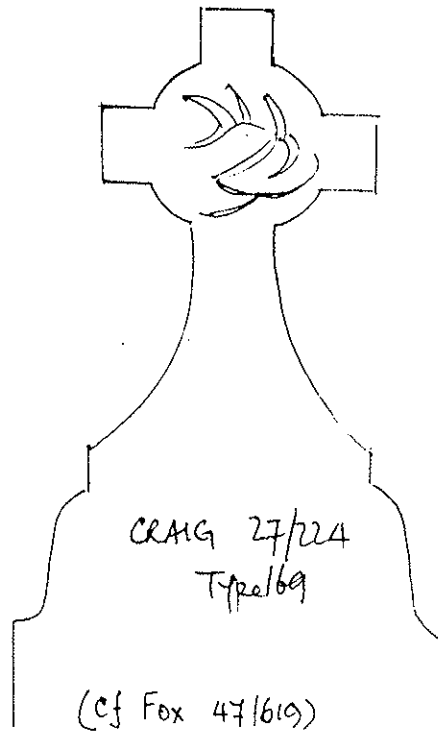
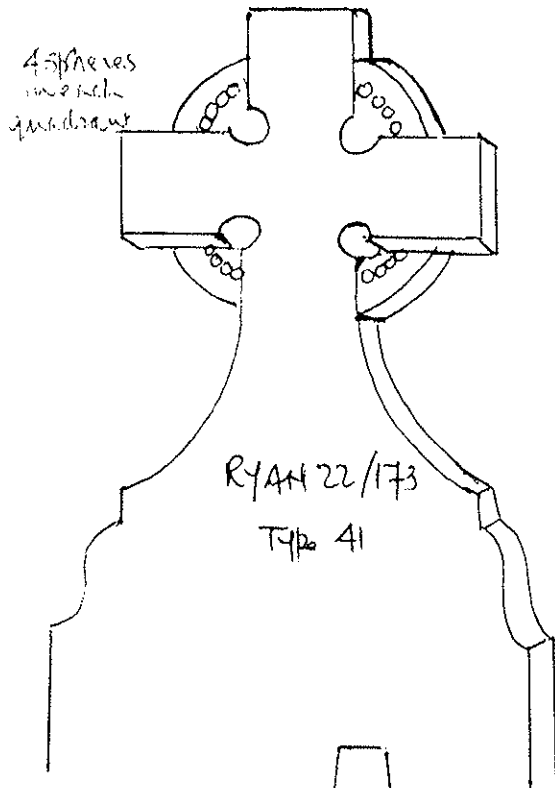

Finnelly
Detail

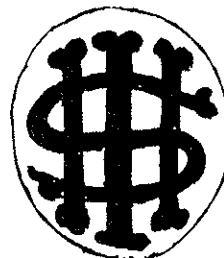

Stands on
3 tiers of
white marble plus
concrete base

PLATE 14

CELTIC CROSSSES ETC

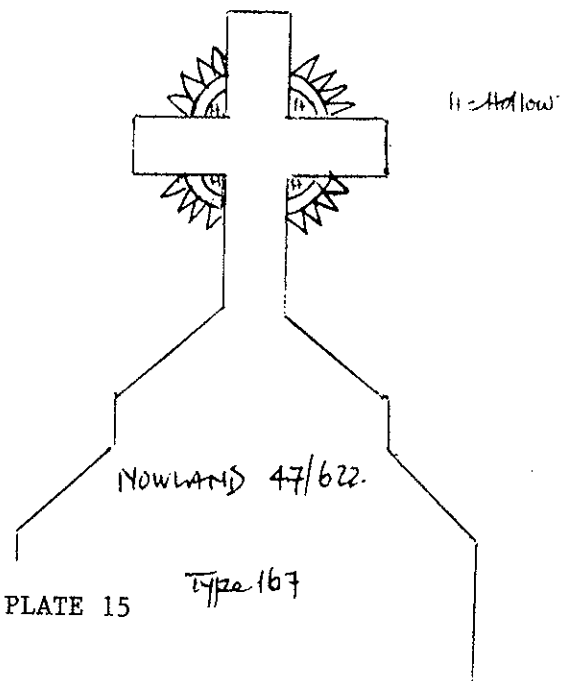
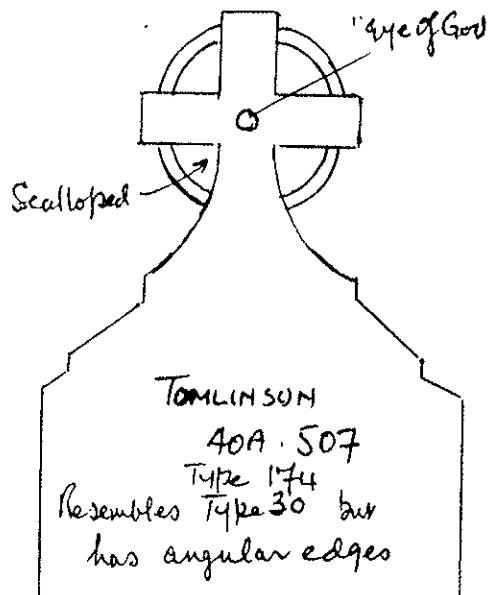
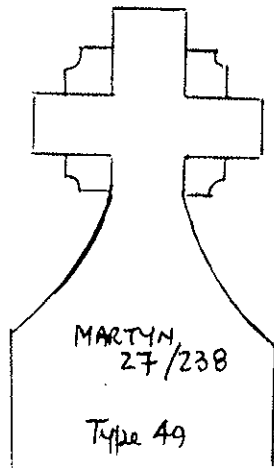
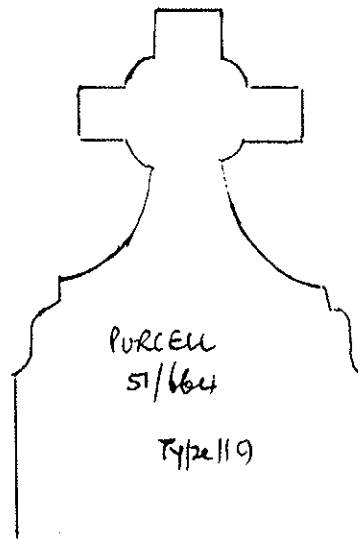
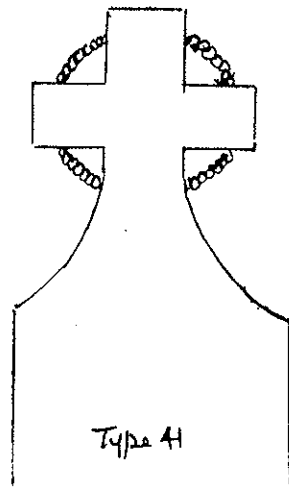
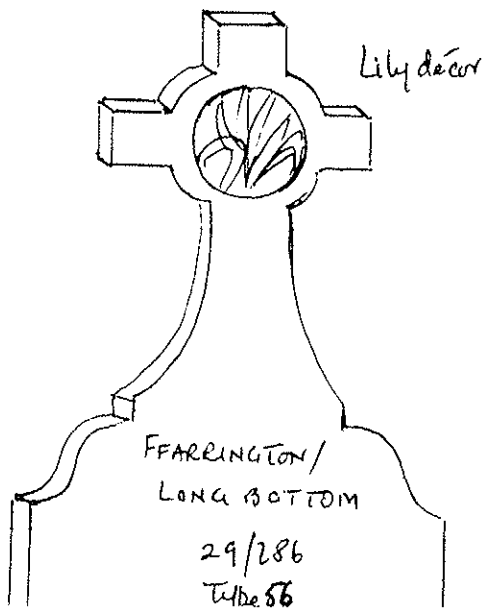
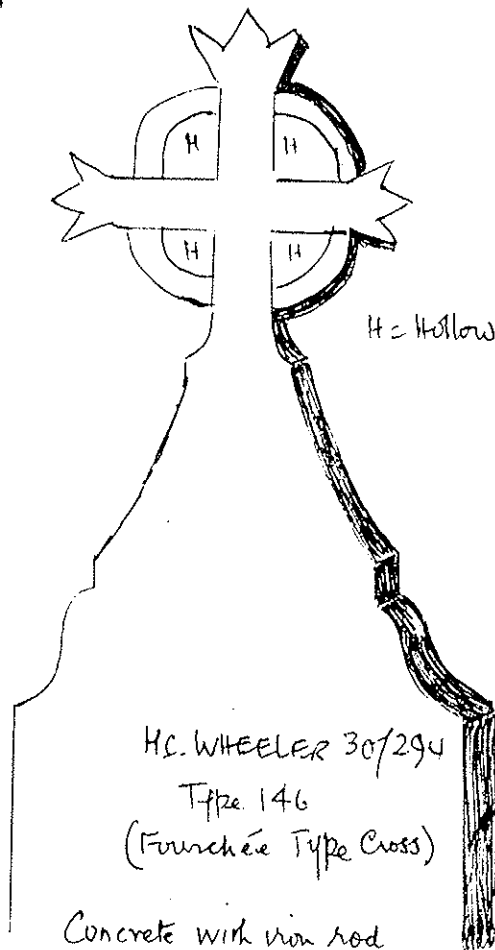
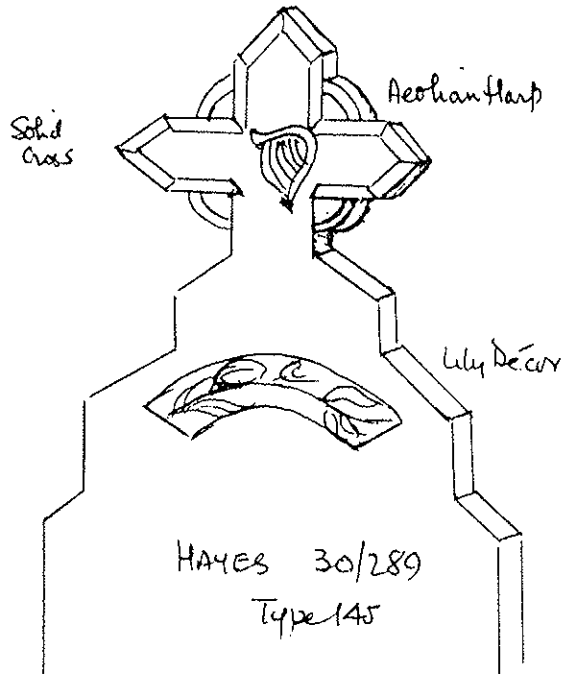
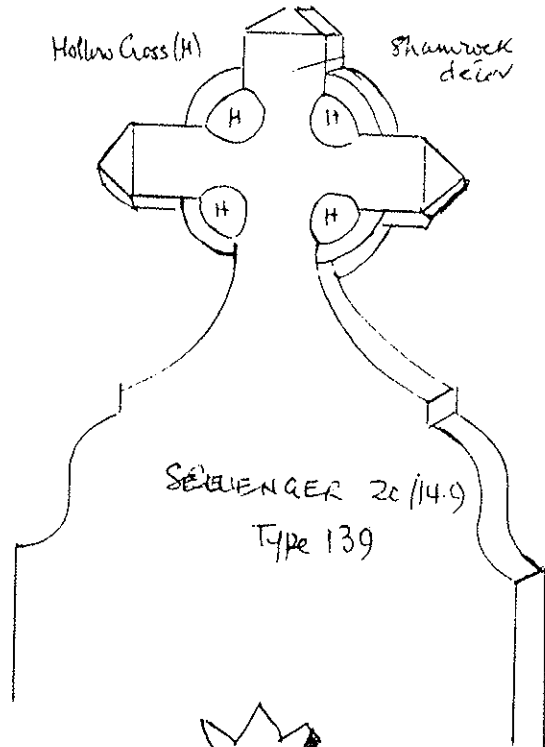
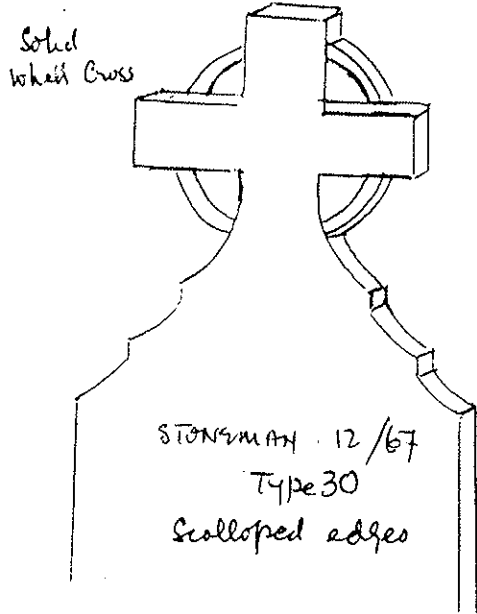

PLATE 15

CELTIC CROSSES -



CROSSES ON SLABS

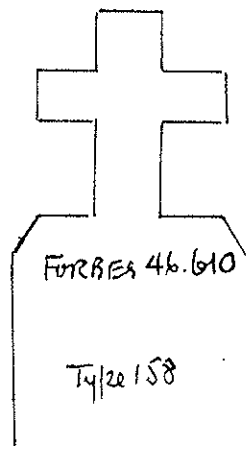
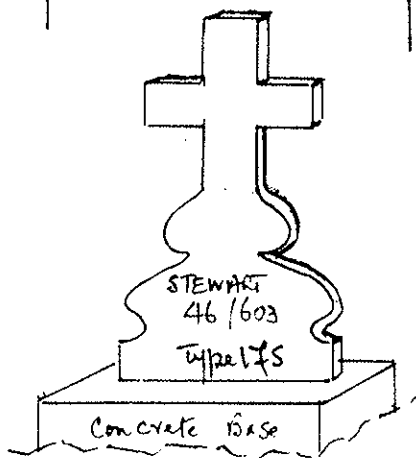
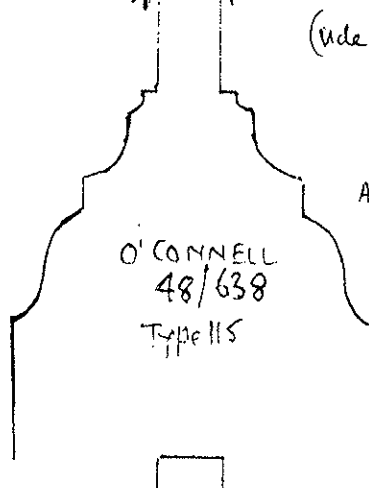
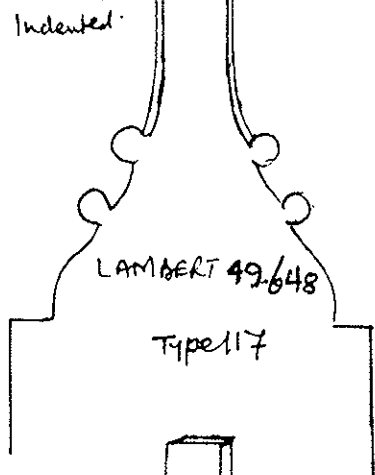
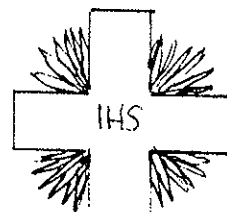
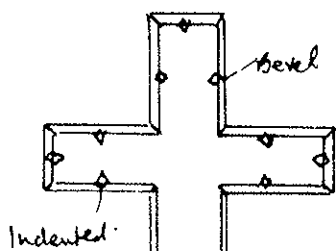
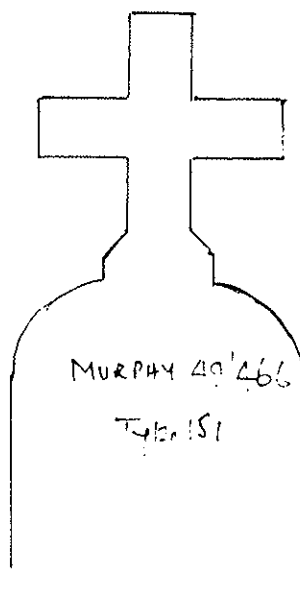
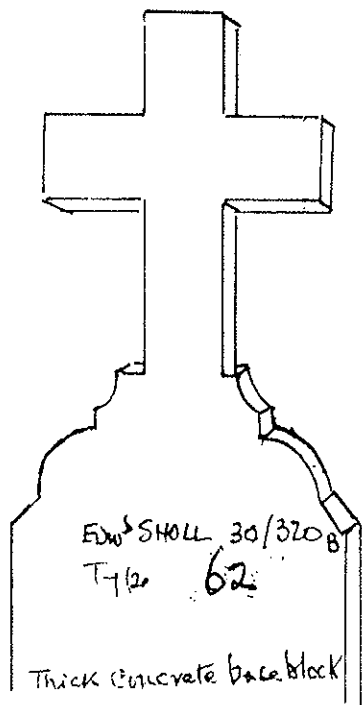

PLATE 17

CROSSES ON SLABS

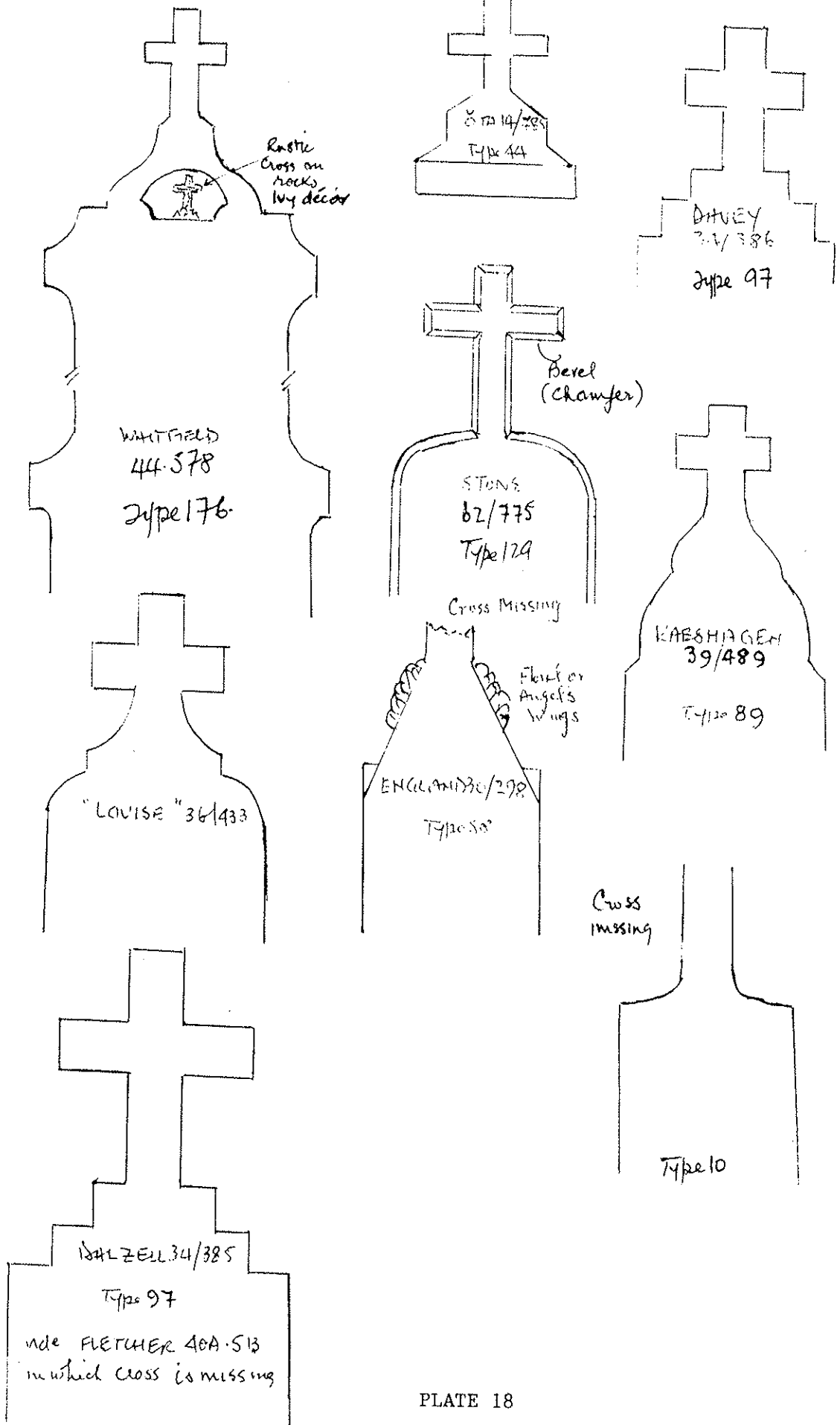
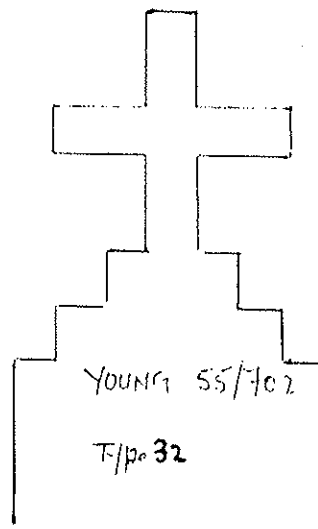
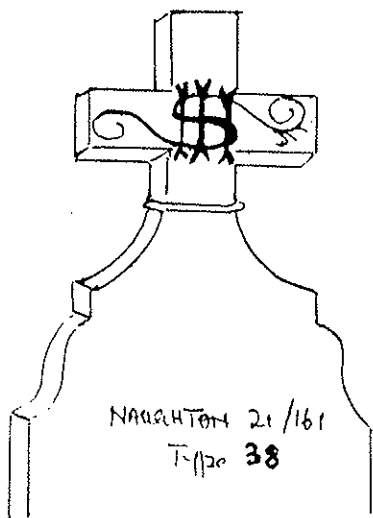

PLATE 18

CROSSES ON SLABS



Elaborate IHS with
Shamrock design
(Duplicated on West-Side)

Cross
Missing

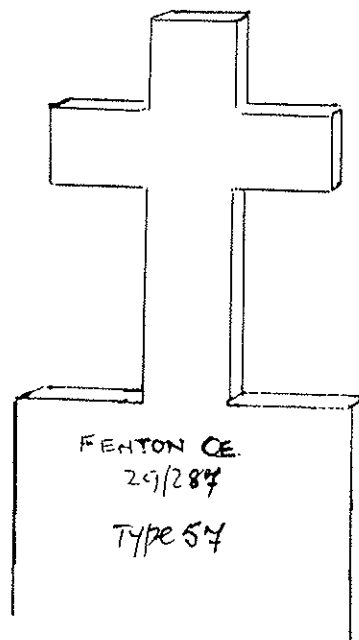
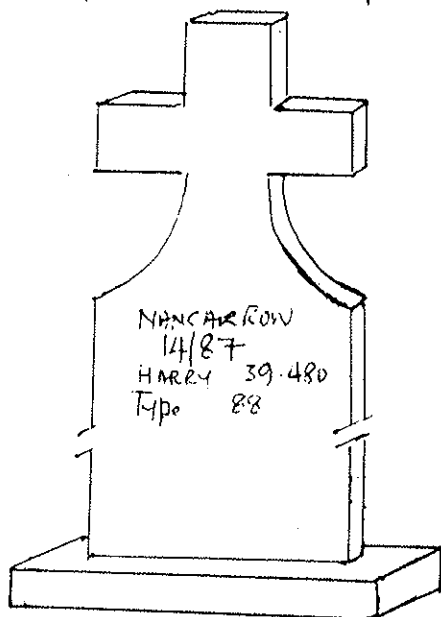
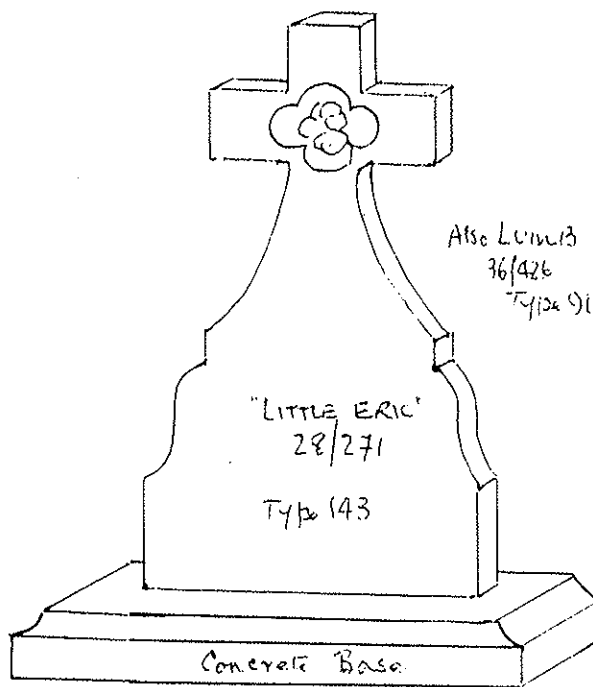
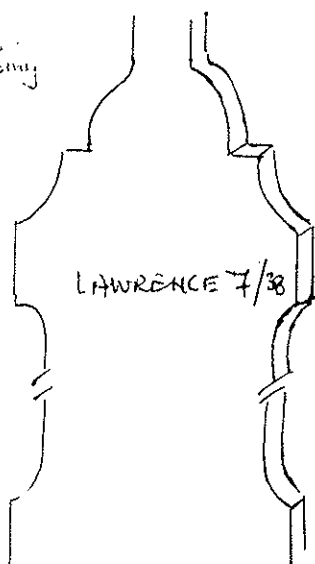

PLATE 19

(Also CAEMICHAEL 30/29)

MISCELLANEOUS CROSSES

Shamrock
Design Cross

Solid

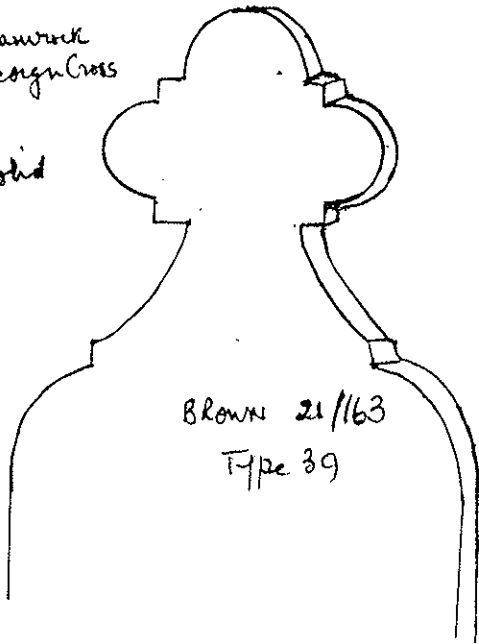

Brown 21/163
Type 39



Rustic in
white marble

Polished
white marble

Rough
marble

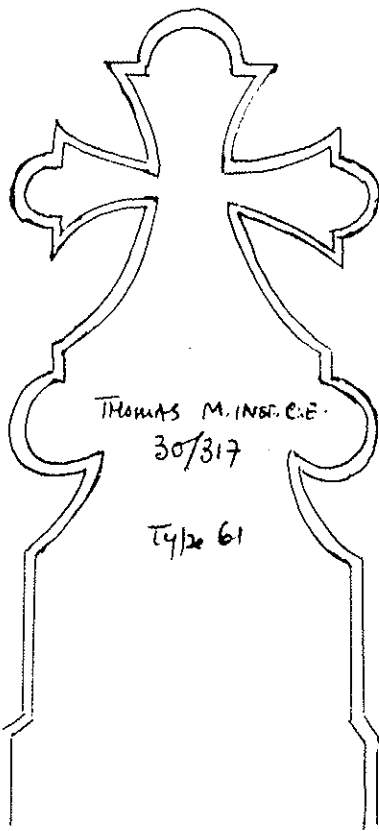
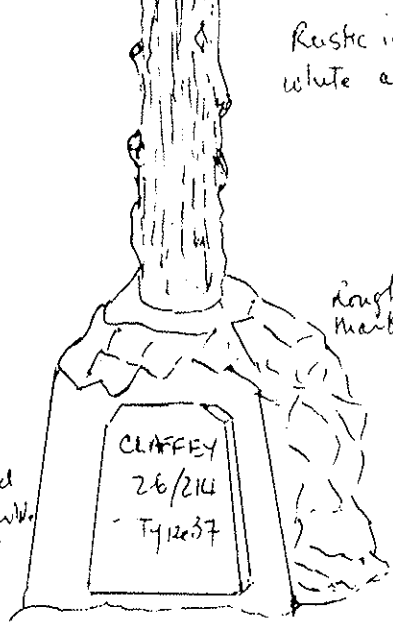

THOMAS M. INSC. C.E.
30/317
Type 61

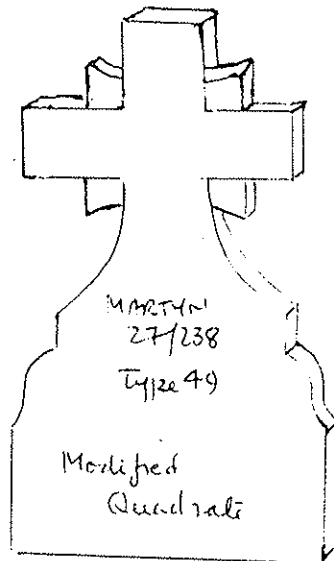

MARTIN
27/238
Type 49
Modified
Quadrangle

MISCELLANEOUS CROSSES

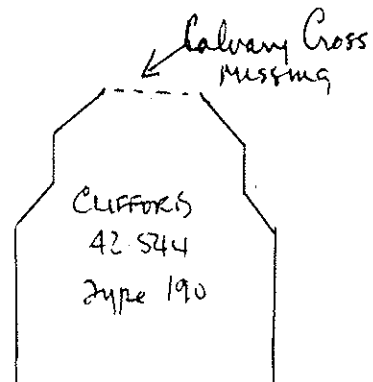
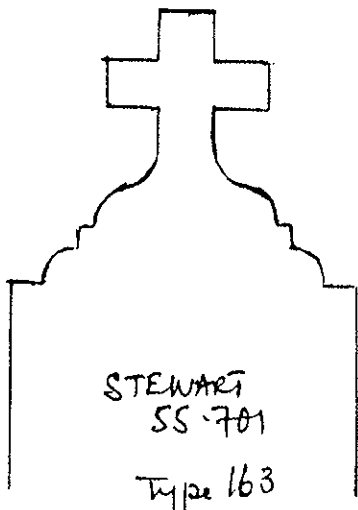
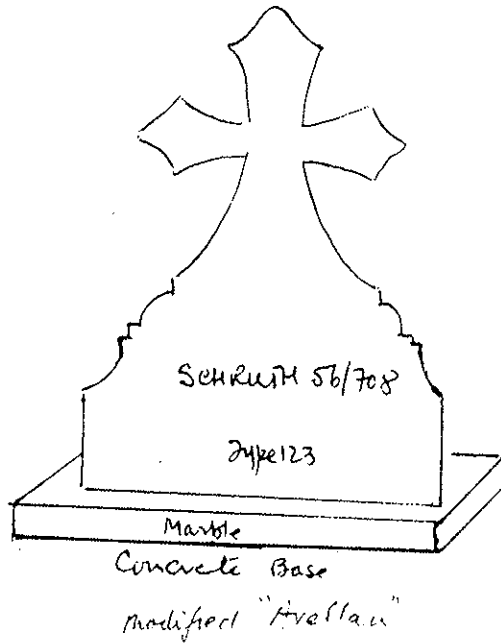
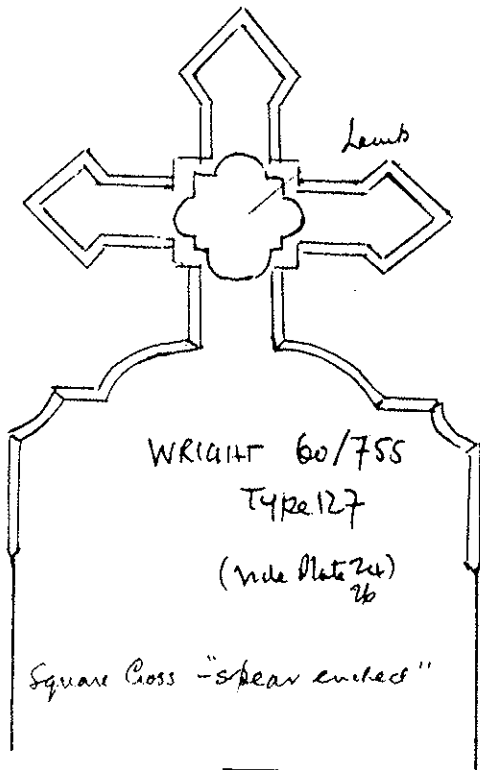
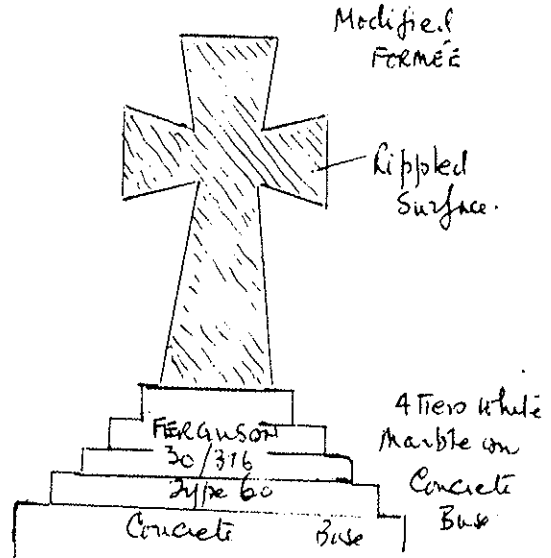
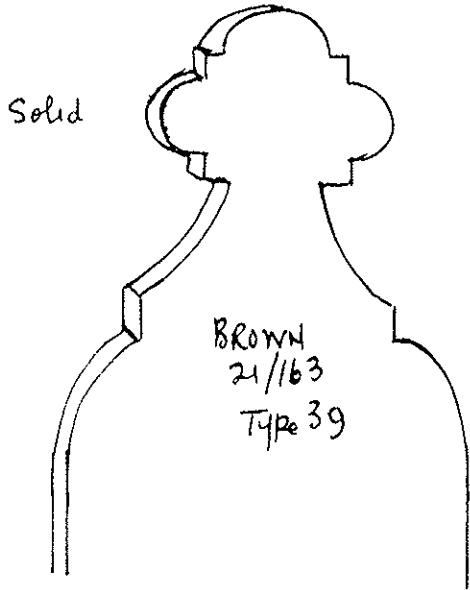

SHIELDS

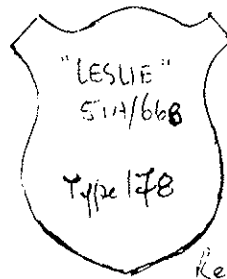

Dimensions
13" x 12 1/2"
Resembles type 120
but is narrower

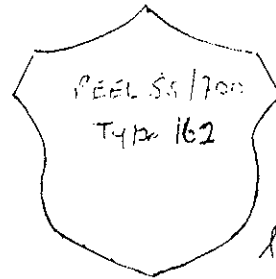
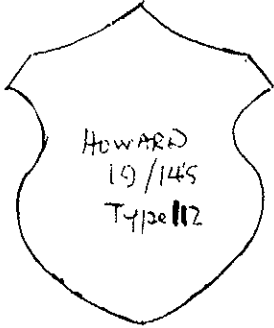

Resembles
type 112 but
less indented

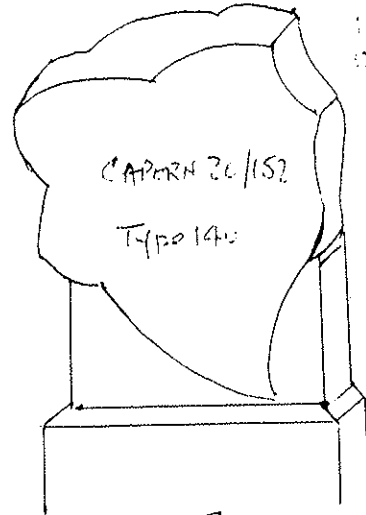
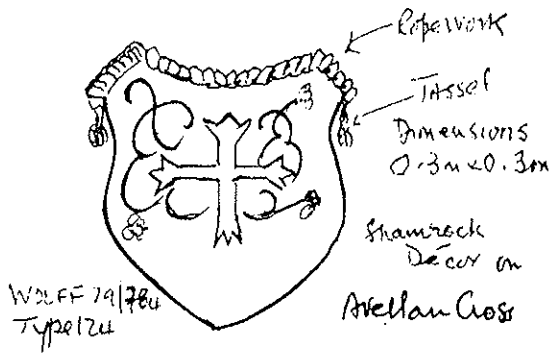

IVY LEAF
Decorations

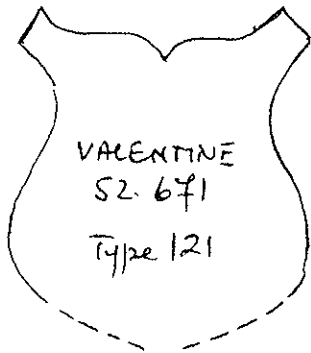

Base
Burned

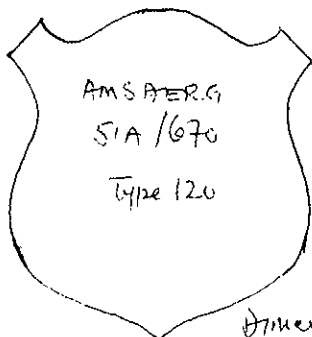

Dimensions
13" x 20"

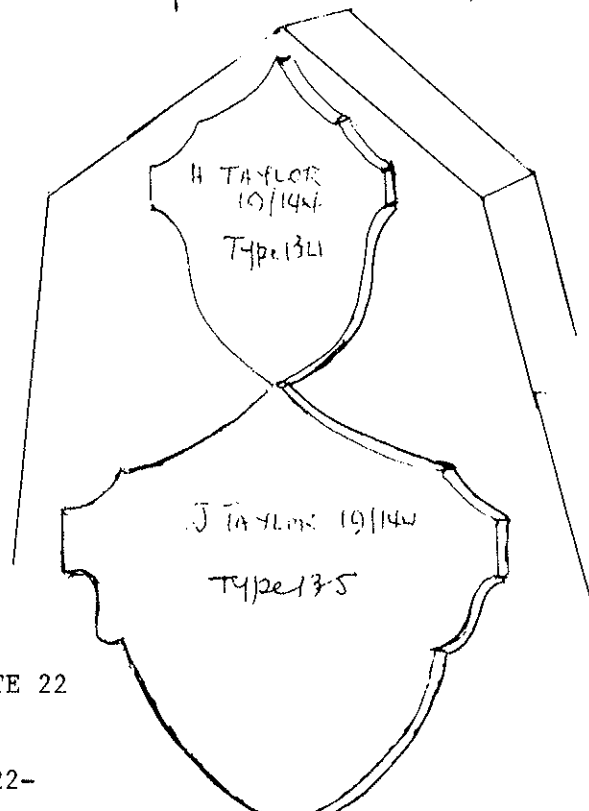
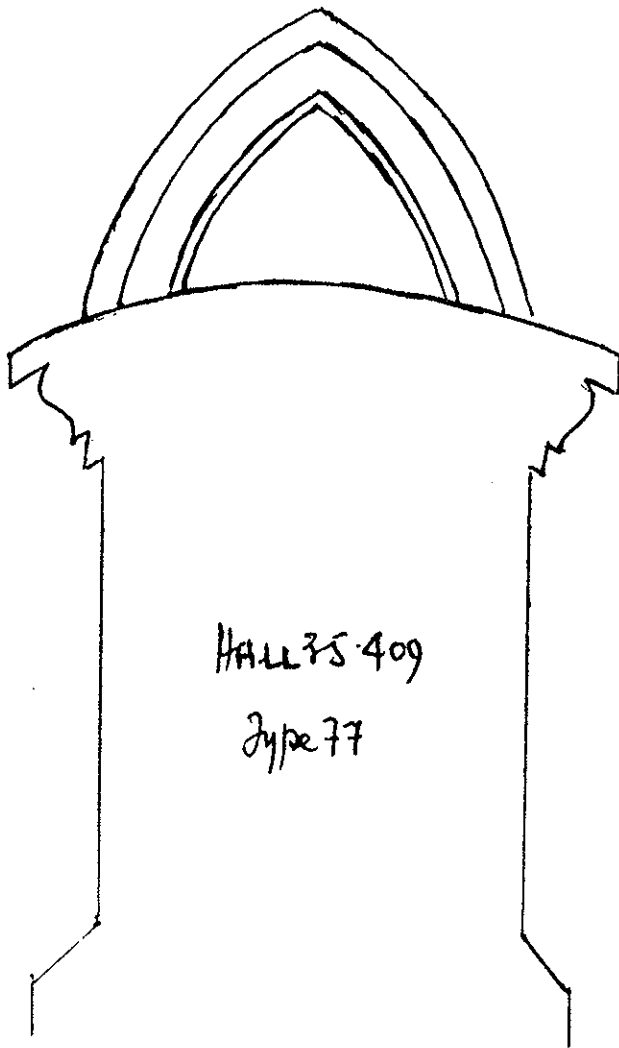
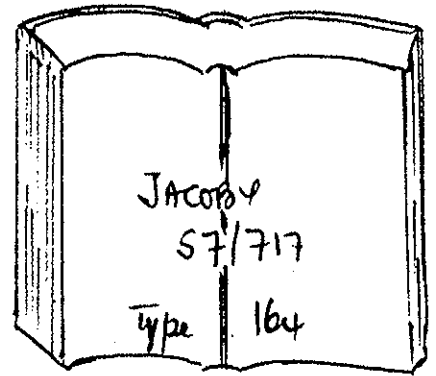

PLATE 22



HALL 35-409

Type 77



JACOBY
57/717

Type 164

Book lying Flat.

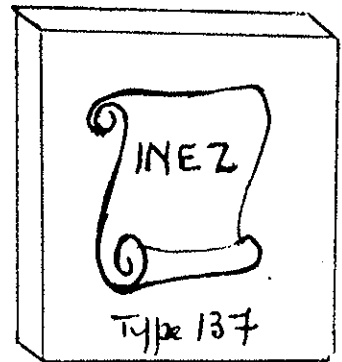

INEZ

Type 137

INEZ 18.125

White
Marble Block
"Rocks"

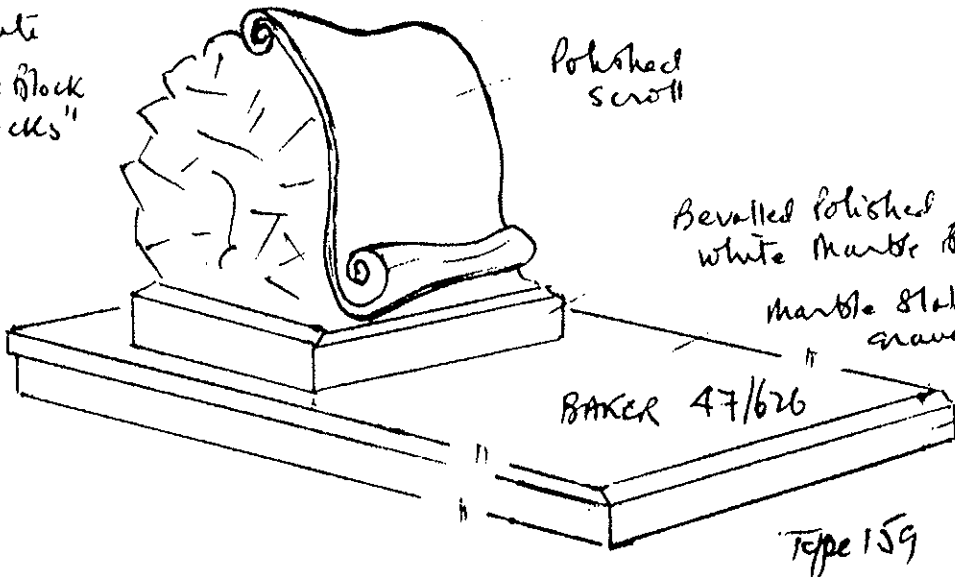

Polished
Scroll

Bevilled Polished
white Marble Block

Marble Slab on
grave (Cracked)

BAKER 47/626

Marble Edging (slab)

Type 159

PLATE 23

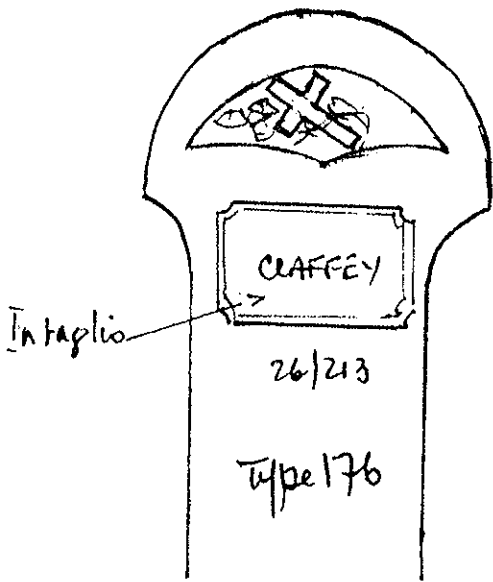

Intaglio

CRAFFEY

26/213

Type 176

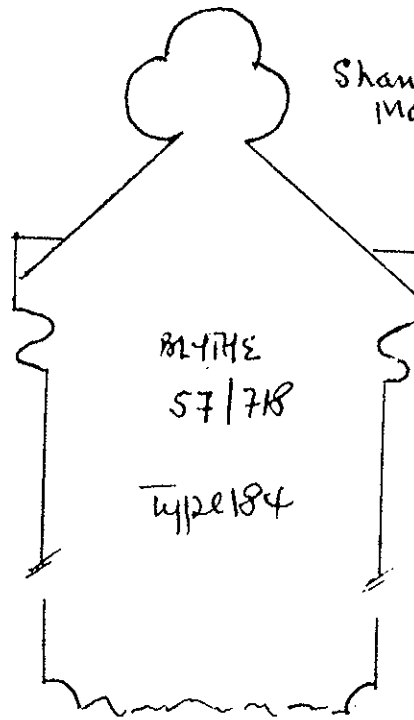

Shamrock Motif on Peaked Slab

BLITHE

57/718

Type 184

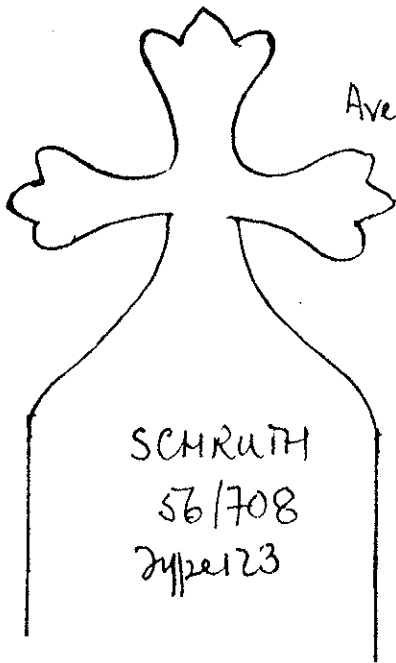

Avellan

SCHRUITH

56/708

Type 123

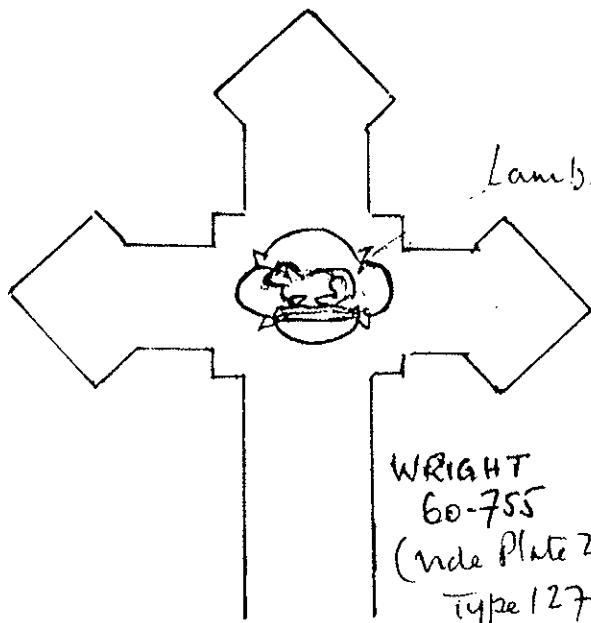

Lamb.

WRIGHT
60-755
(vide Plate 21, 26)
Type 127

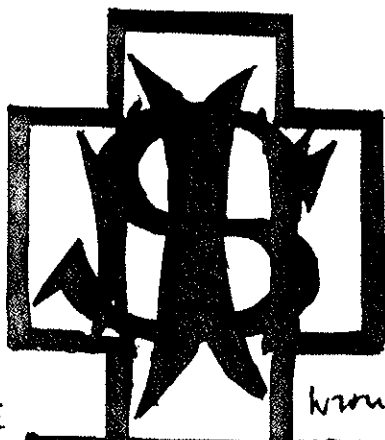

HOYLE
19/143

wrought iron
Plaque

Type 35

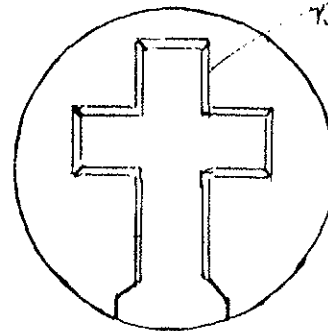

Reval.

Top Panel
on H.S.

O'CONNOR 22/176

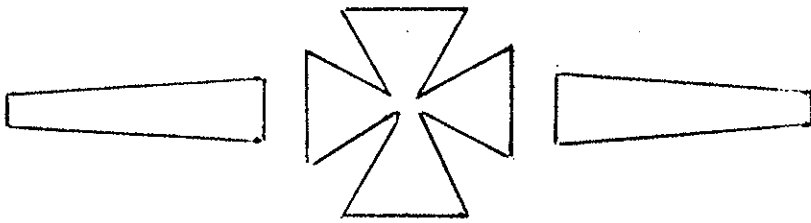

TIDDY 15/92
Modified Patee

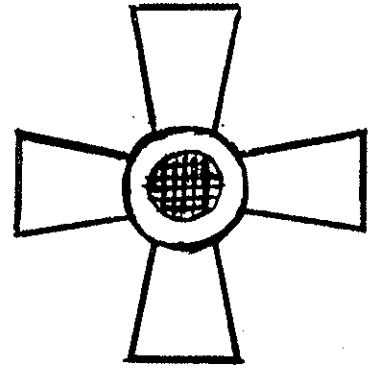

MORONEY 46/604
"Eye of God" Motif
ON PATEE CROSS

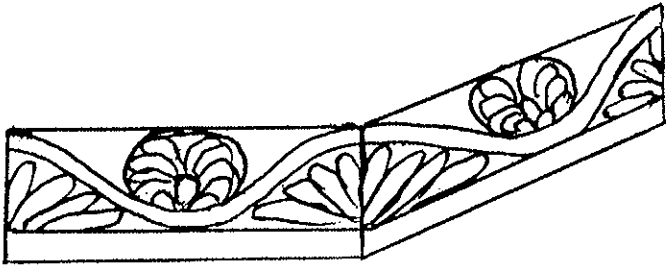

CLARKSON & KEY 20/151
Plinth below Broken Column with
Floral Garland
(Possible Flame Motif)

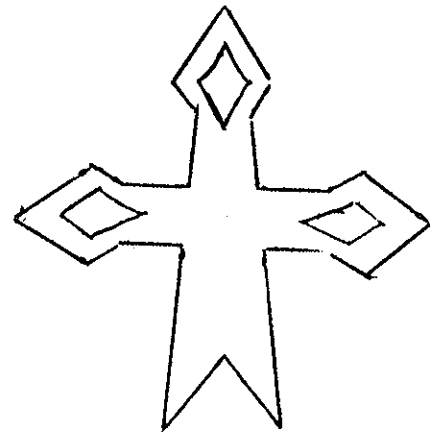

CONNELL 47A/780

Sunrise 13 Rays



Rising Sun
(each side)
2x13 rays



WILLOW
Garland
IHS
ROBINSON 31/324
(see Plate 58)
Type 182

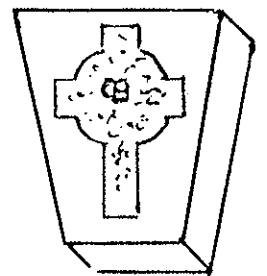

STEWART 46/603
Plaque on Grave top
Cross filled with
Sea-shells

MISCELLANEOUS

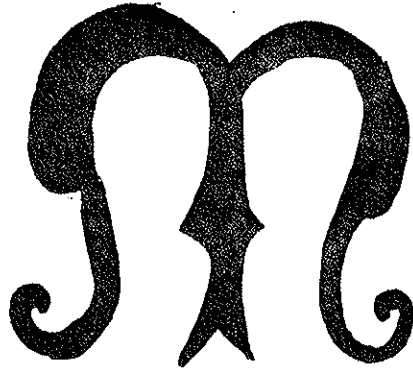
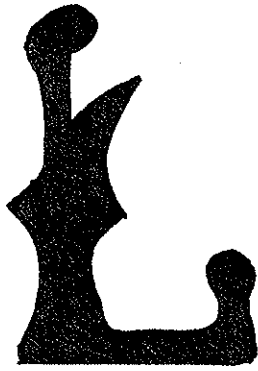

MEARES 56-710

Part of "IN LOVING MEMORY"

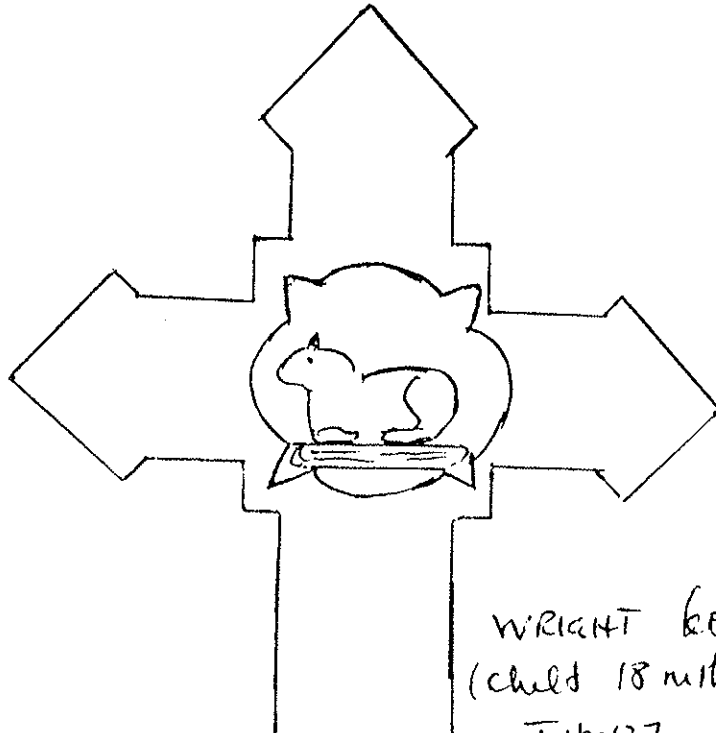

WRIGHT 60-755
(child 18 mths).

type 27

Lamb Kneeling

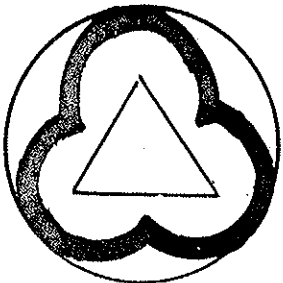

HILLAS 1-4
Eternity Symbol
in Panel

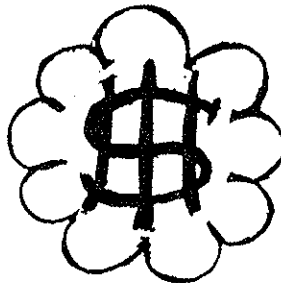

RANFORD 30-310

MISCELLANEOUS

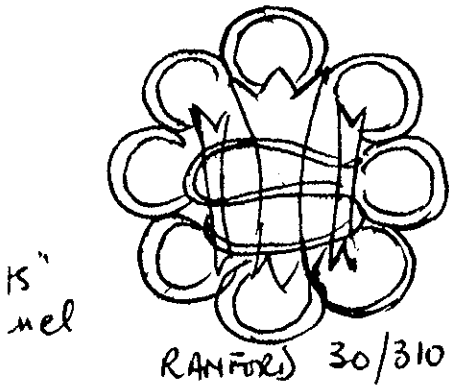

15" nel

RANFORD 30/310

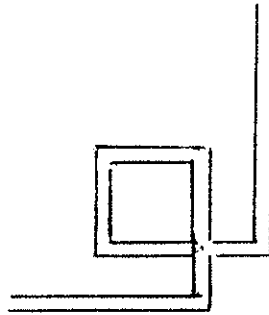

MANN 33A/677
Rebated Moulding in
corners of headstone

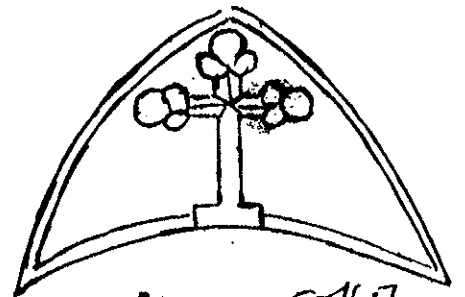

MORRIS 50/656
Panel with
Shamrock Cross
Type 161 (Panel)

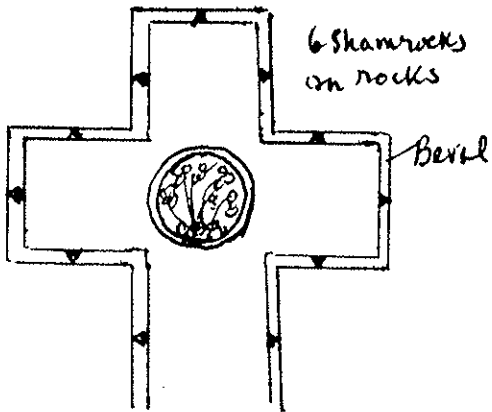

LAMBERT 49/648

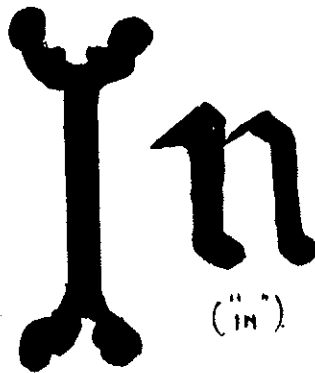

("in")

MURPHY 49/646

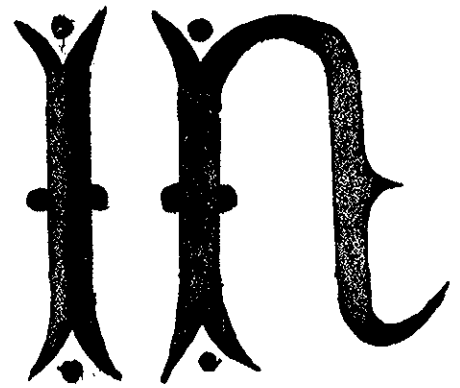

BOLADERAS 24/211



DEARBEN 22/203

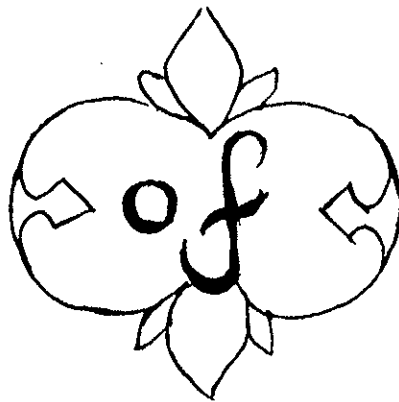

McMAHON 24/211

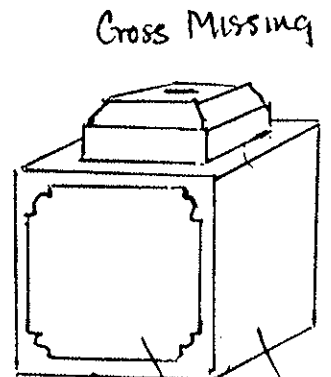

White Marble Plaque
Concrete Block

12-68 SCHILDT

CALLIGRAPHY



Wm SMITH 36/460



Frederick GATWOOD 30-297.

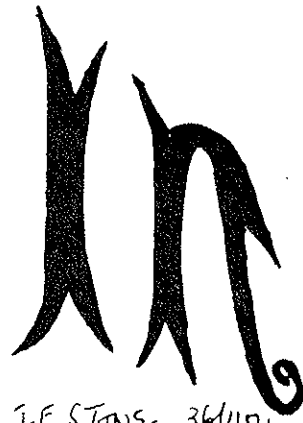

J.F. STONE 36/454.

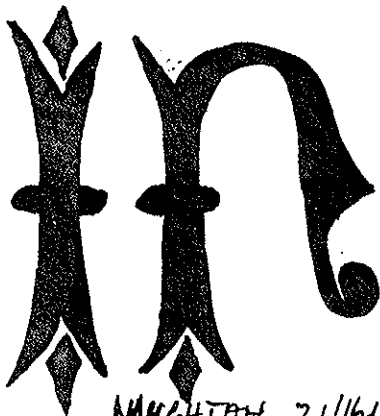

NAUGHTON 21/161. (No  over n)
McGRATH 41/522

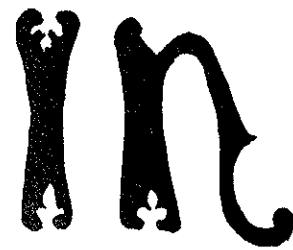

COL. FINNERTY 30/300

CALLIGRAPHY



(IN)

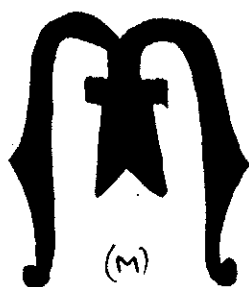

(M)



(F)

HUTCHINSON 47/630

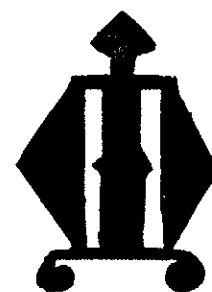

(M)

GAME 44/580



LILLIS 42/541 (IMS)



DICKSON 27/219 (M)



(M)

REGAN 20/148

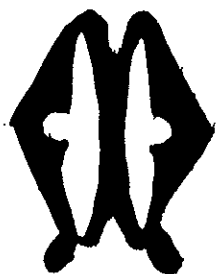

(M)

SPENCER 35/418

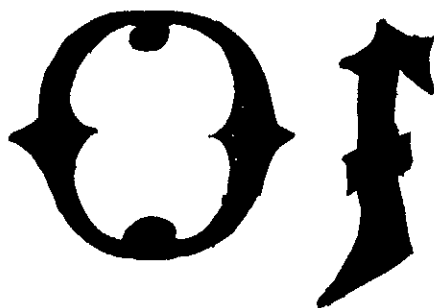

M. HOYNE 39/486



(M)

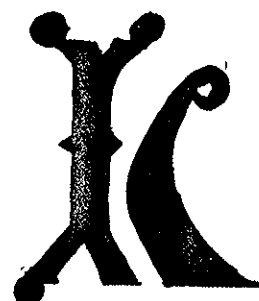

(IN)

CALLIGRAPHY & DECOR



114
Shamrock

McARBLE 35/401

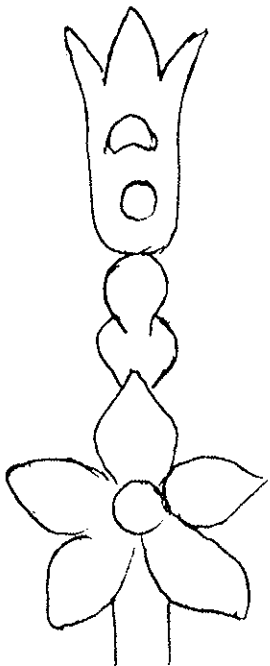

Decoration on Shoulders of Headstone
McARBLE 35.407

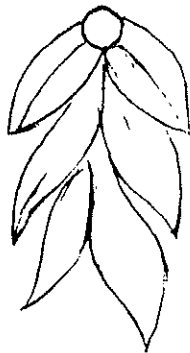

Sunrise decor

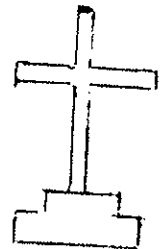

Latin Cross on each
Shoulder of H.S.

SMITH 34.384

(note Plate 10)
Type 183

PLATE 30

WROUGHT IRON FENCING

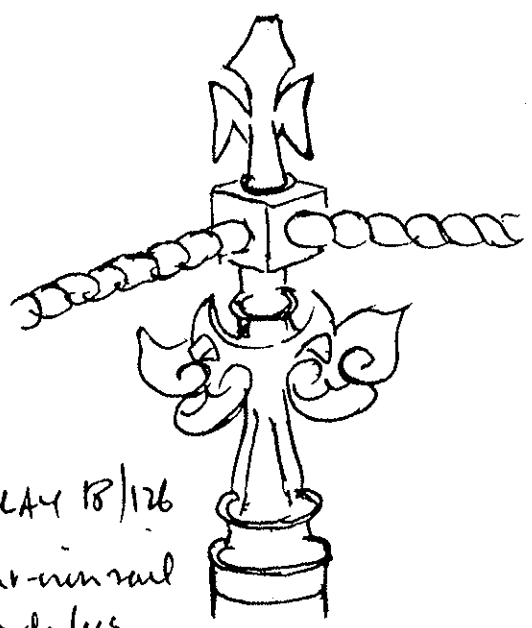

CLAY 18/126
Wrought-iron rail
+ fleur-de-lys
paling.

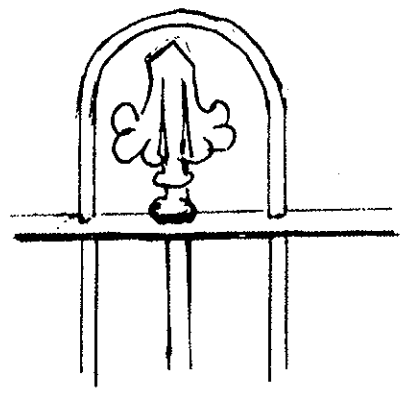

MORRISON 36/461

Hoop + paling wrought iron
Fence.

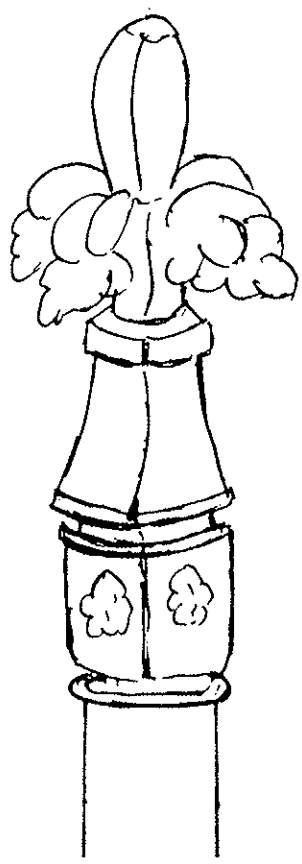
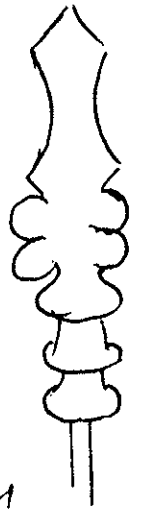

GATWOOD
30/297
wrought iron
fencing

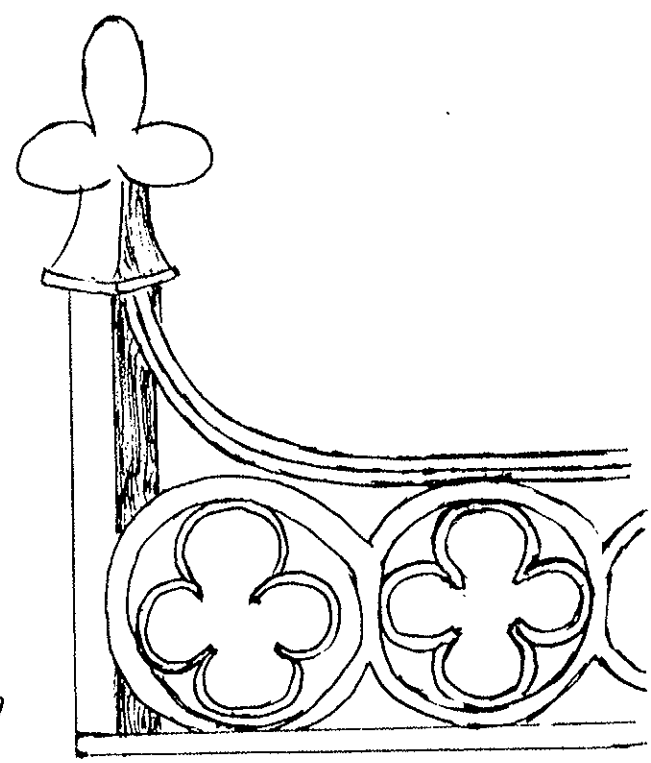

elaborate design

WROUGHT IRON FENCING

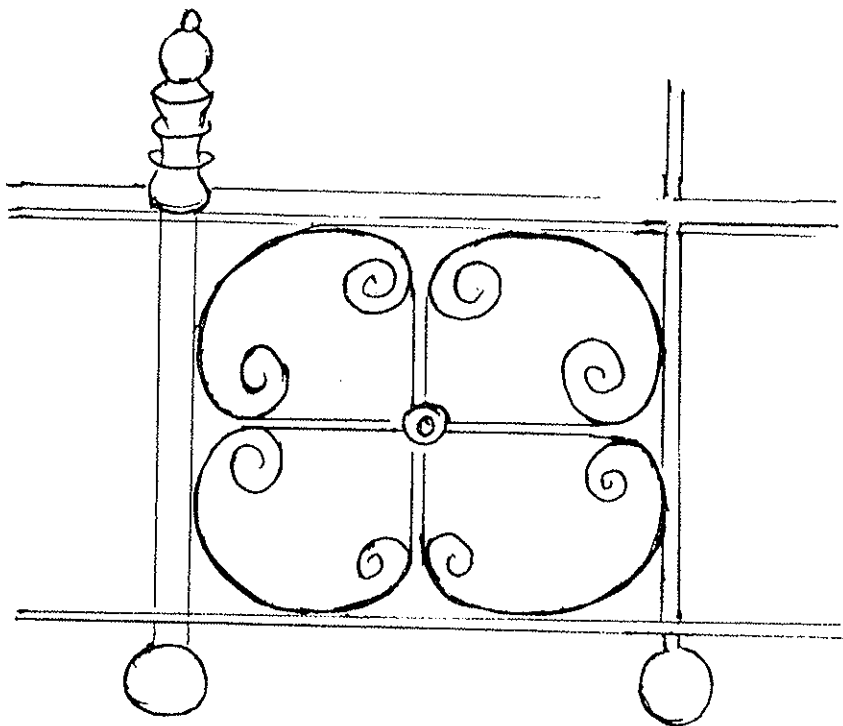
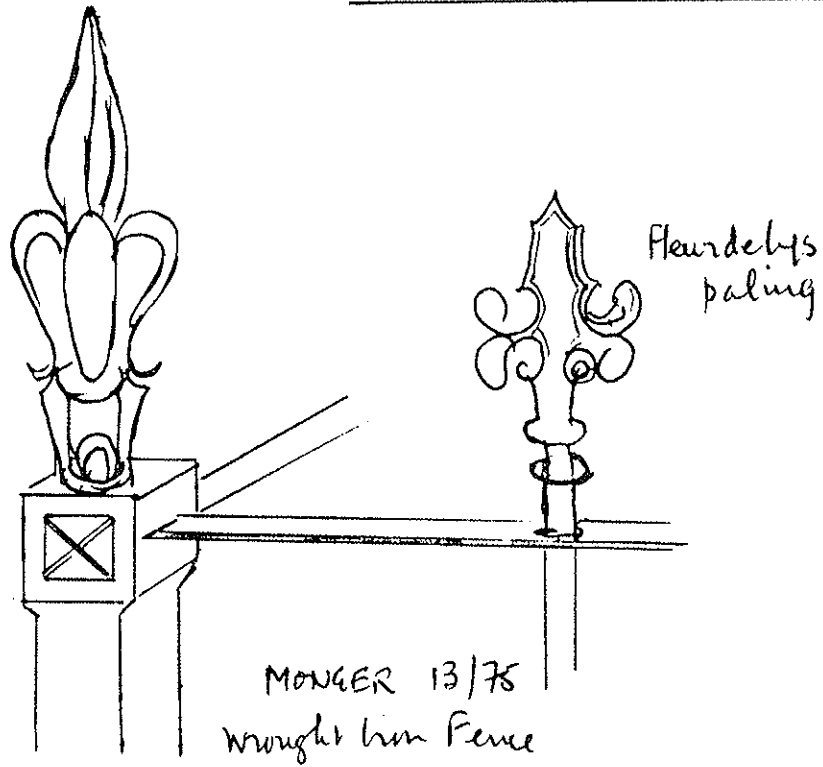
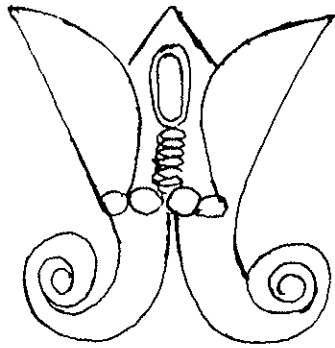

PLATE 32

ORNAMENTAL SLABS



Fleur-de-lis
on Norman
Arch

GRIGSON 44-582



REGAN 20-148
M in Memoriam



MORRISON 36-461
rustic Cross with Ivy
on rocks
type

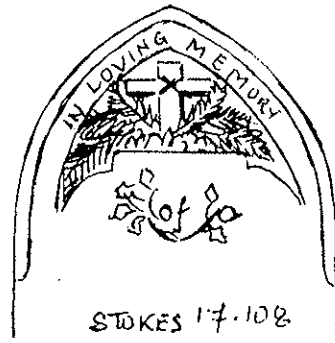

STOKES 17-108
FERN & Ivy Décor
type 8

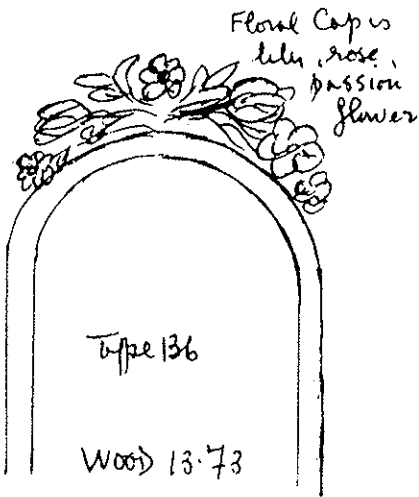

Floral Cap is
lily, rose,
passion
flower

Type 136

WOOD 13-73

Floral Capping on
Norman Arch.
Rose or Poppy

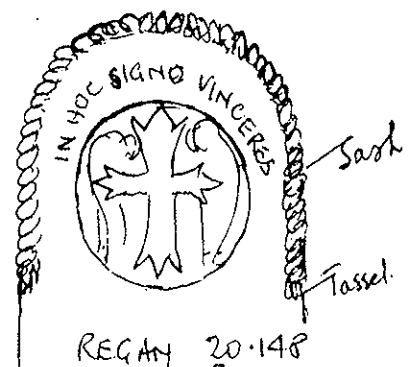

REGAN 20-148
Type 138
Sash around Norman Arch
Two Angels against
Avellan Cross

ORNAMENTAL SLABS



Detail
vide Pl. 33

GRIGSON
44-582
Type 1

Fern + Fleur de lis
on Norman slab

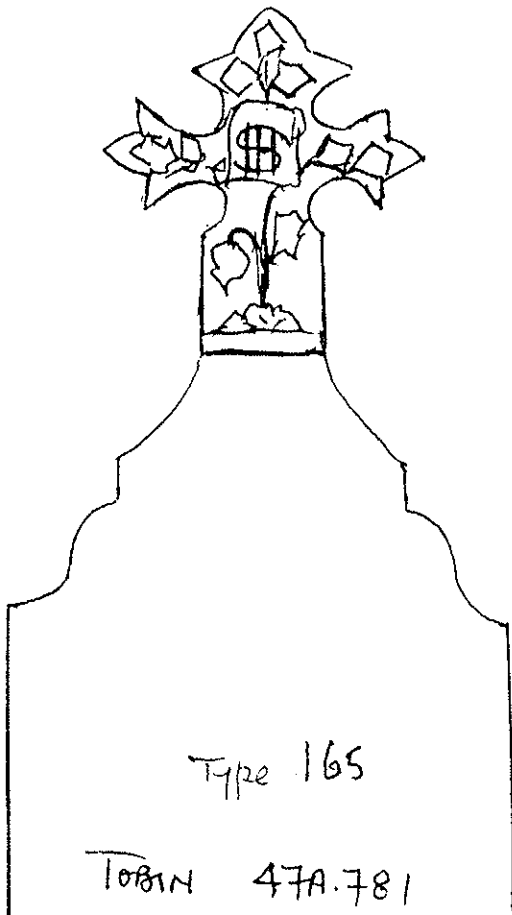

Type 165

TOBIN 47A-781

Avellan Cross with Ivy

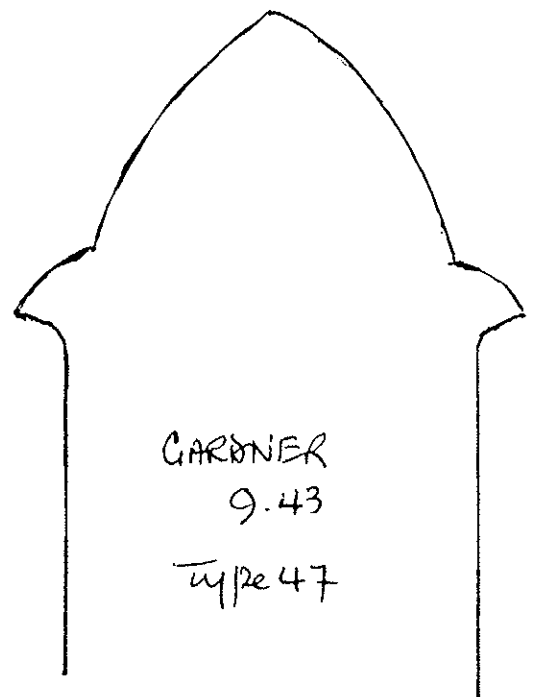

GARDNER
9-43
Type 47

ORNAMENTAL SLABS

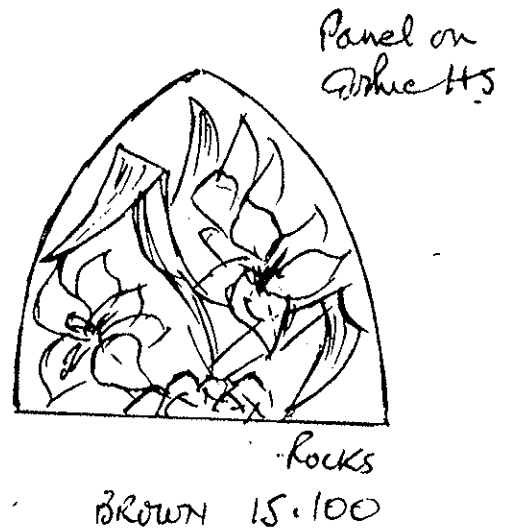
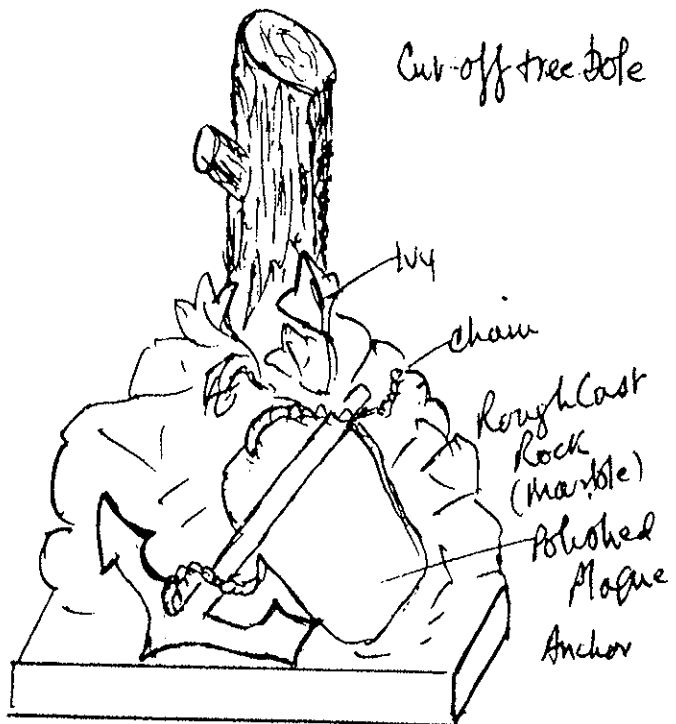
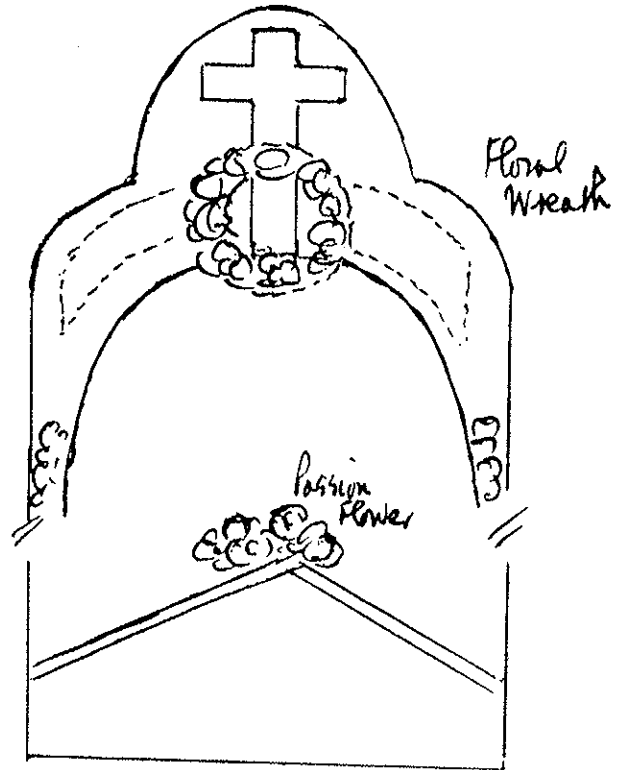
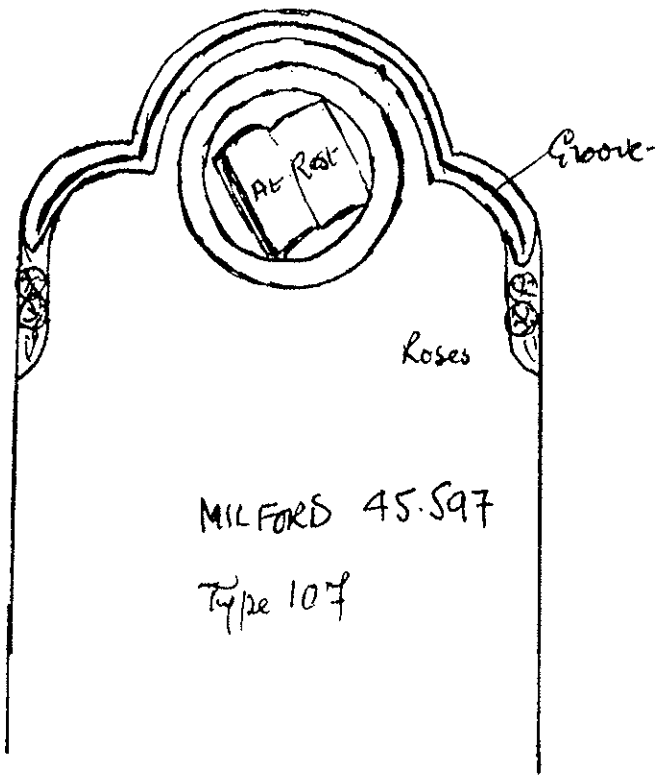

CHEST & HEADSTONES

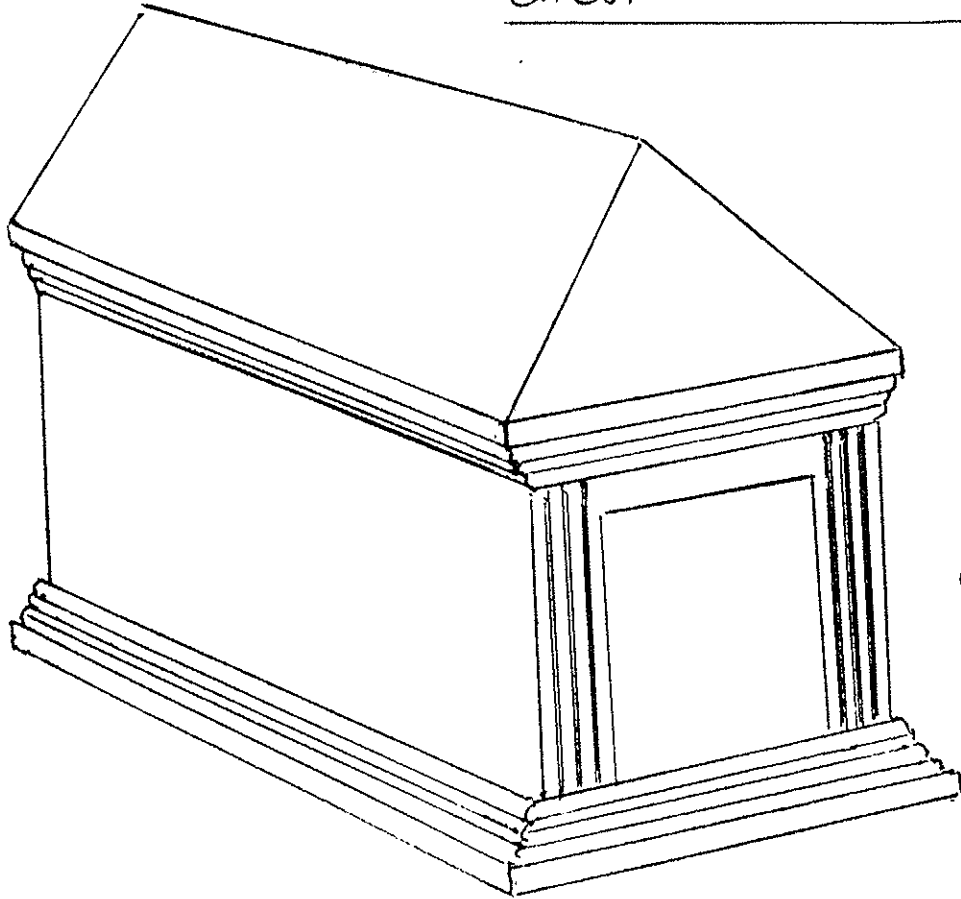

Peaked chest
SMENTON 15.94
Type 22

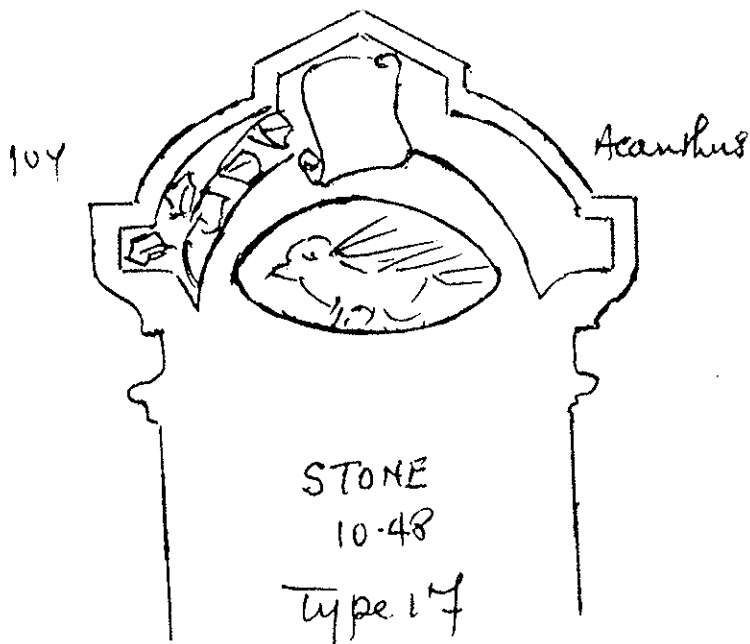
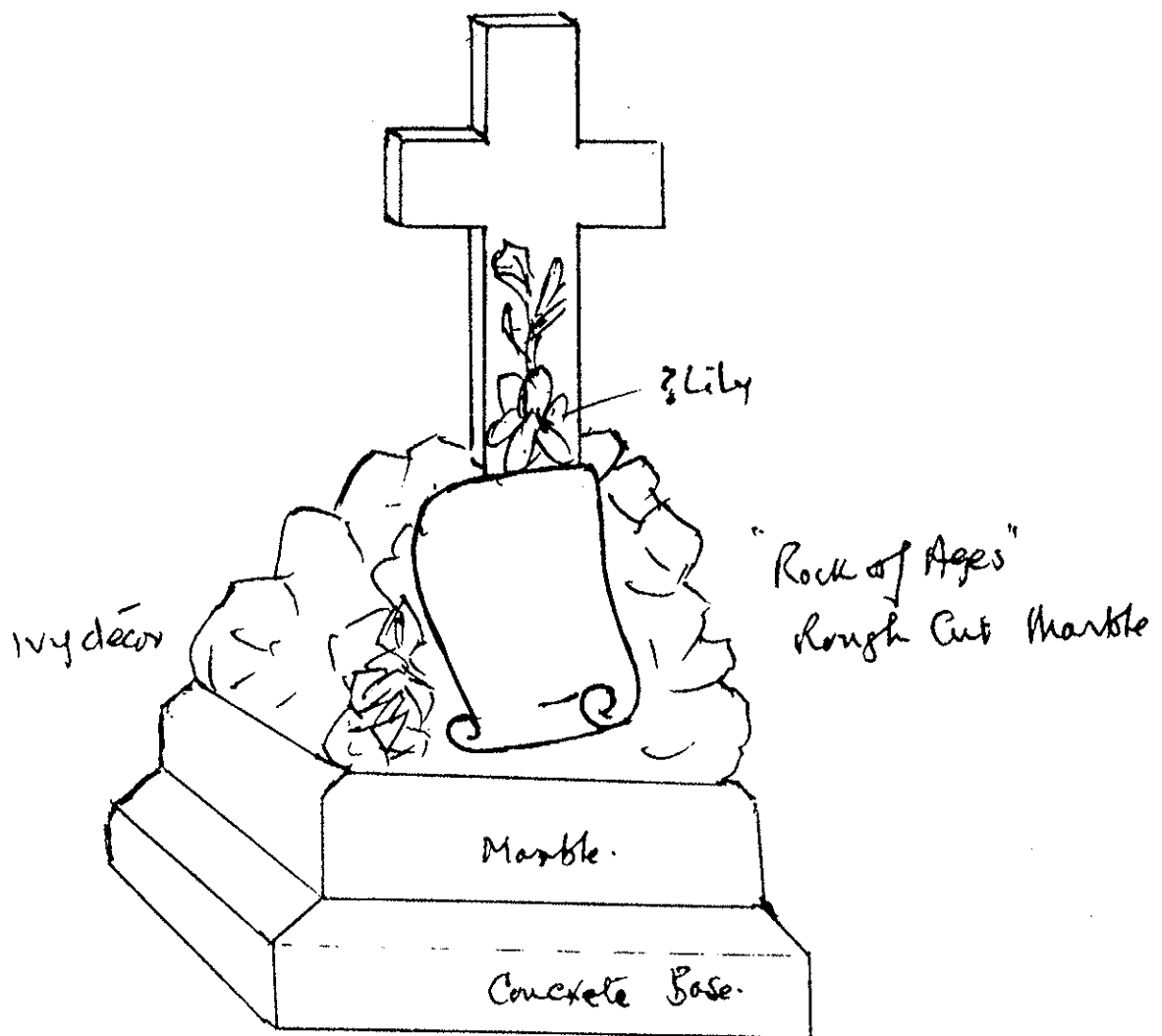

PLATE 36

Cross on Rock with SCROLL



MACLAGAN 27-226

SYMBOLS & CALLIGRAPHY

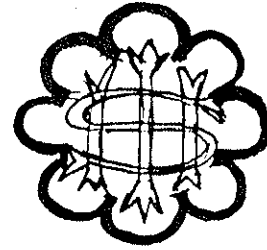
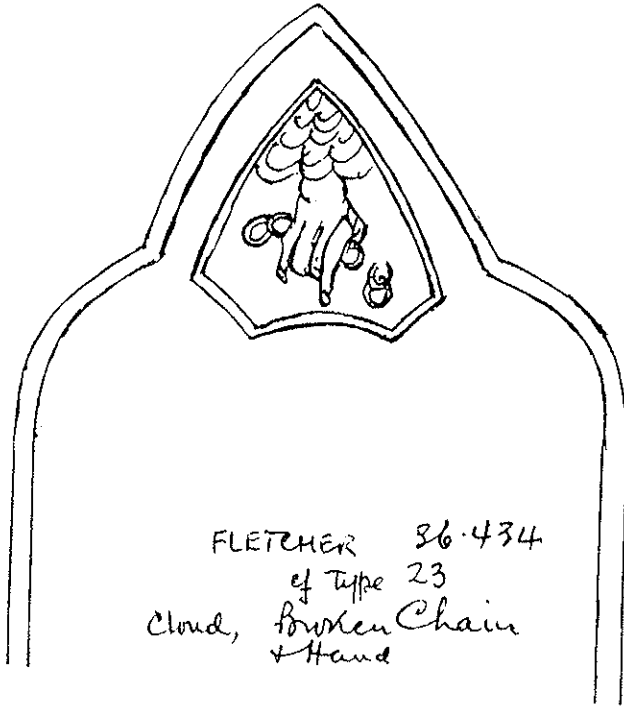

"In Hoc Signo"



Hearts &
 Cross

RANFORD 30.310



BULLEN 35.407

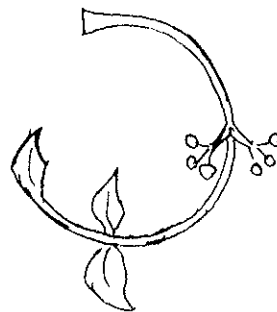

Capt. John VROUHAERT 43.560

WROUGHT IRON FENCING

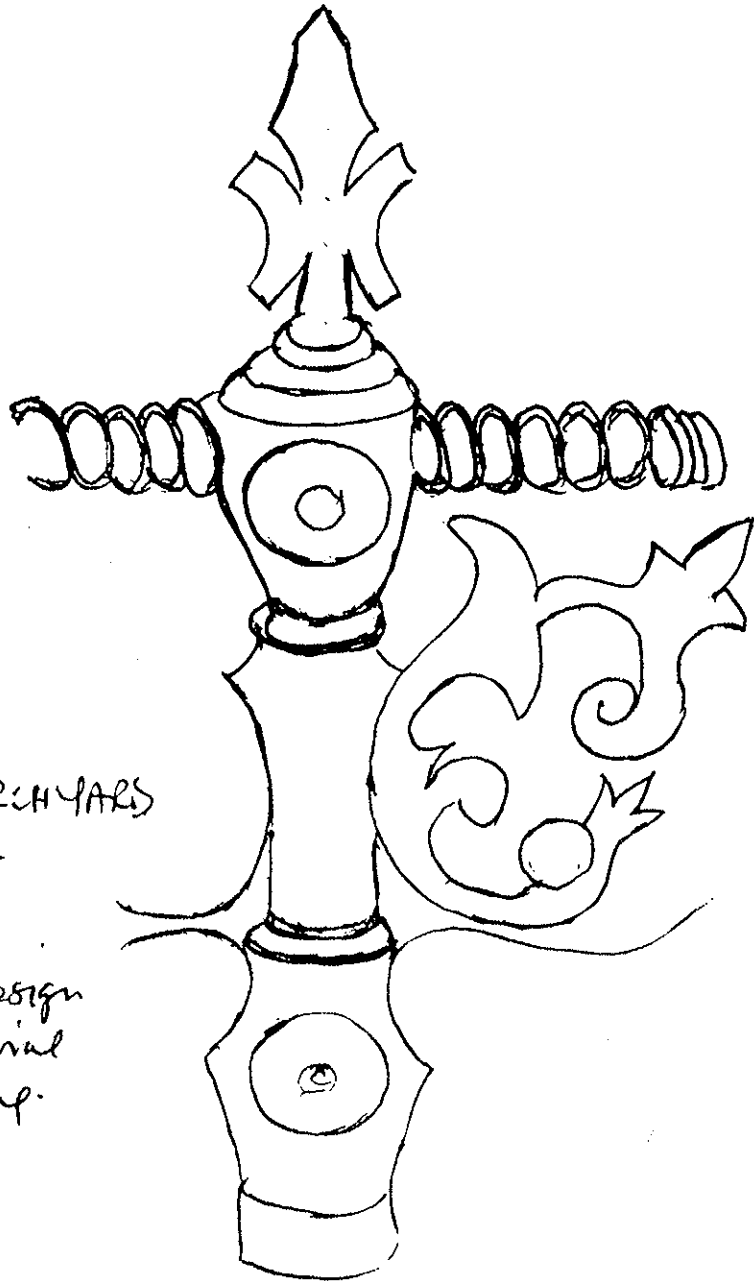

MITCHELL + CHURCHYARD
36.457

Fleur de Lis design
Wrought Iron Spiral
railing.

CALLIGRAPHY + DÉCOR

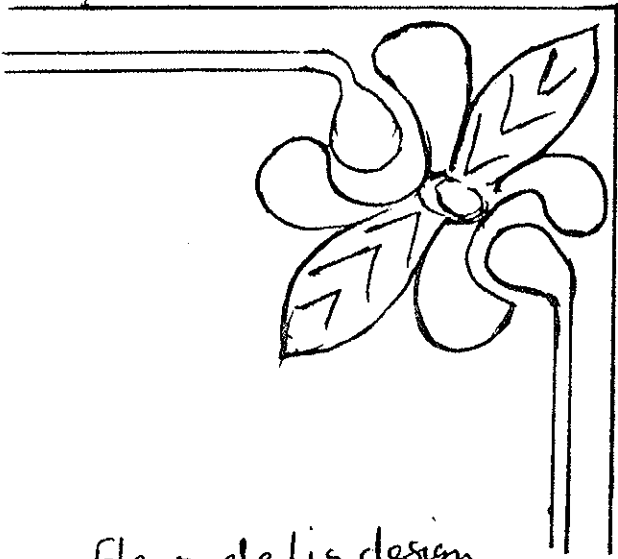

Fleur de lis design
on ledger



SUTHERLAND 32.362



Abraham WHITE 43.561

CALLIGRAPHY

WYLDRE

Joseph WYLDRE 46-612

(Carved in a smooth curve across headstone)

WYLDRE

RUFEY 45-595

CALLIGRAPHY & DÉCOR

THE A

WEDMOREY

BWENSIDE 44.572

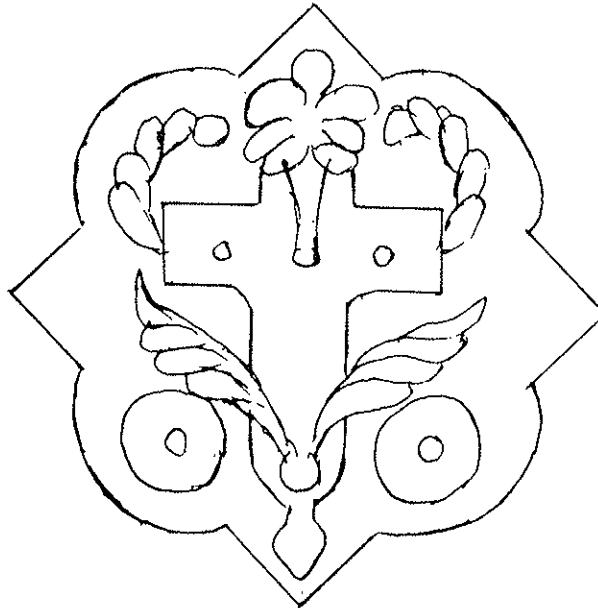

*Elaborate Page
on Heatstone
(Capital)*

DARCH 43.566

PLATE 42

CALLIGRAPHY DECOR

SACRED

KYLE
38-466

M
(M)

P
(Y)

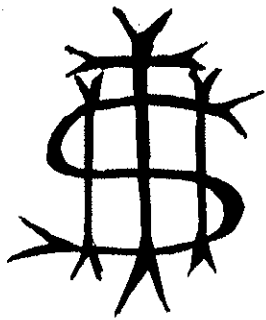

GRAY 47A-783

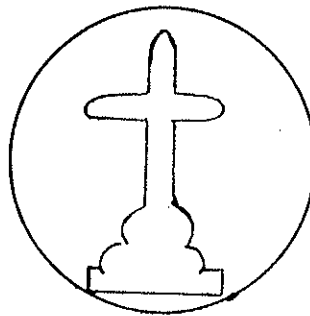

*Pencil on
leaked slab*

Mc COURT 30-290

M a g P S
their

NAUGHTON
31-322

PLATE 43

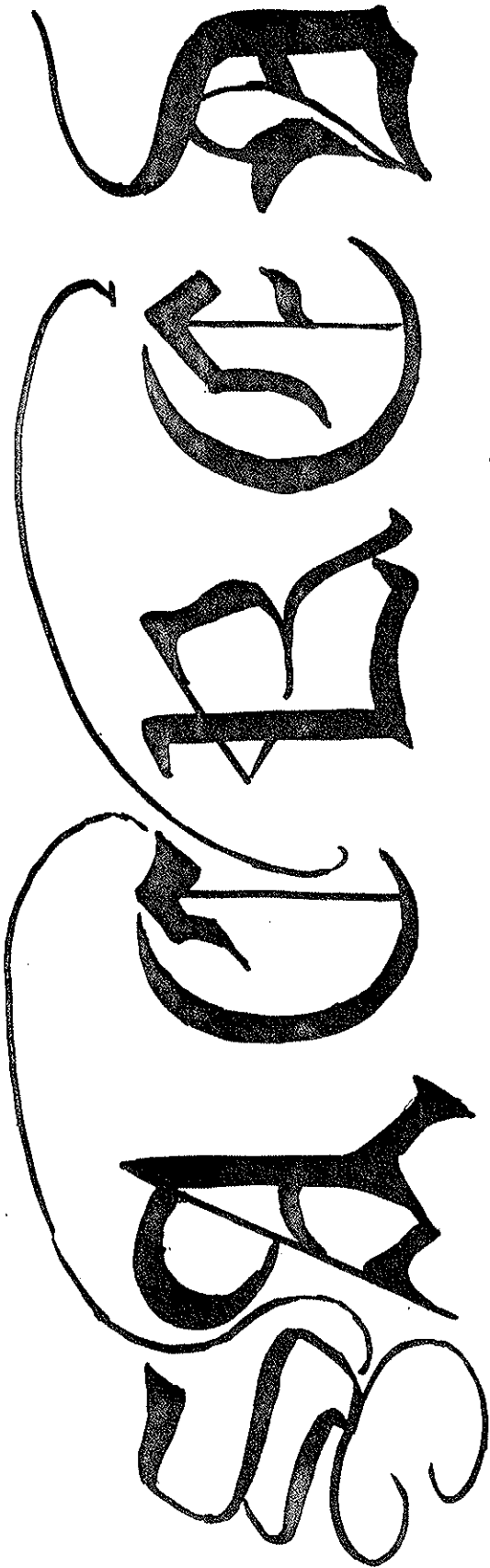

Decorated with elaborate Curlicues

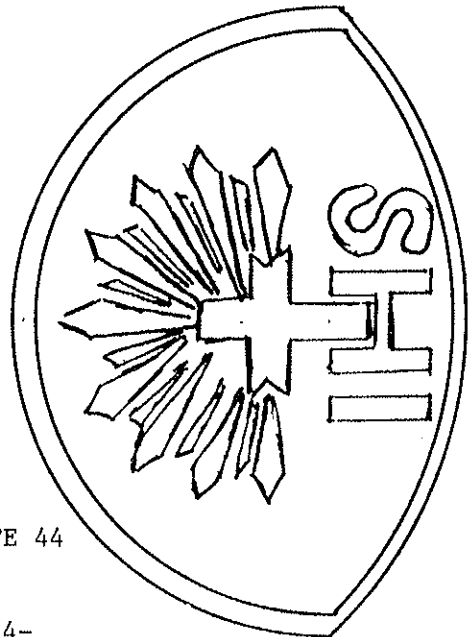

Inscribed Panel

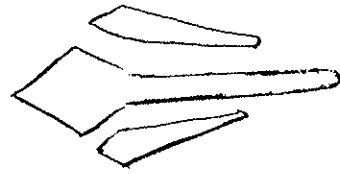

Detail of Design in Panel

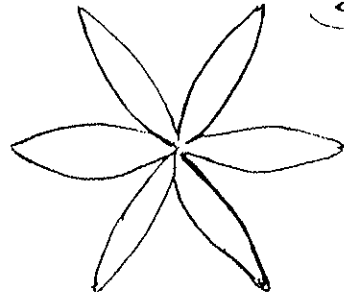

Design on R.H. Corner of Headstone

(Oldest R.C. Stone in E.P.C.)

HORAN & Mc GUNNESS

31-321

Headstone Type 63 (Plate 8)

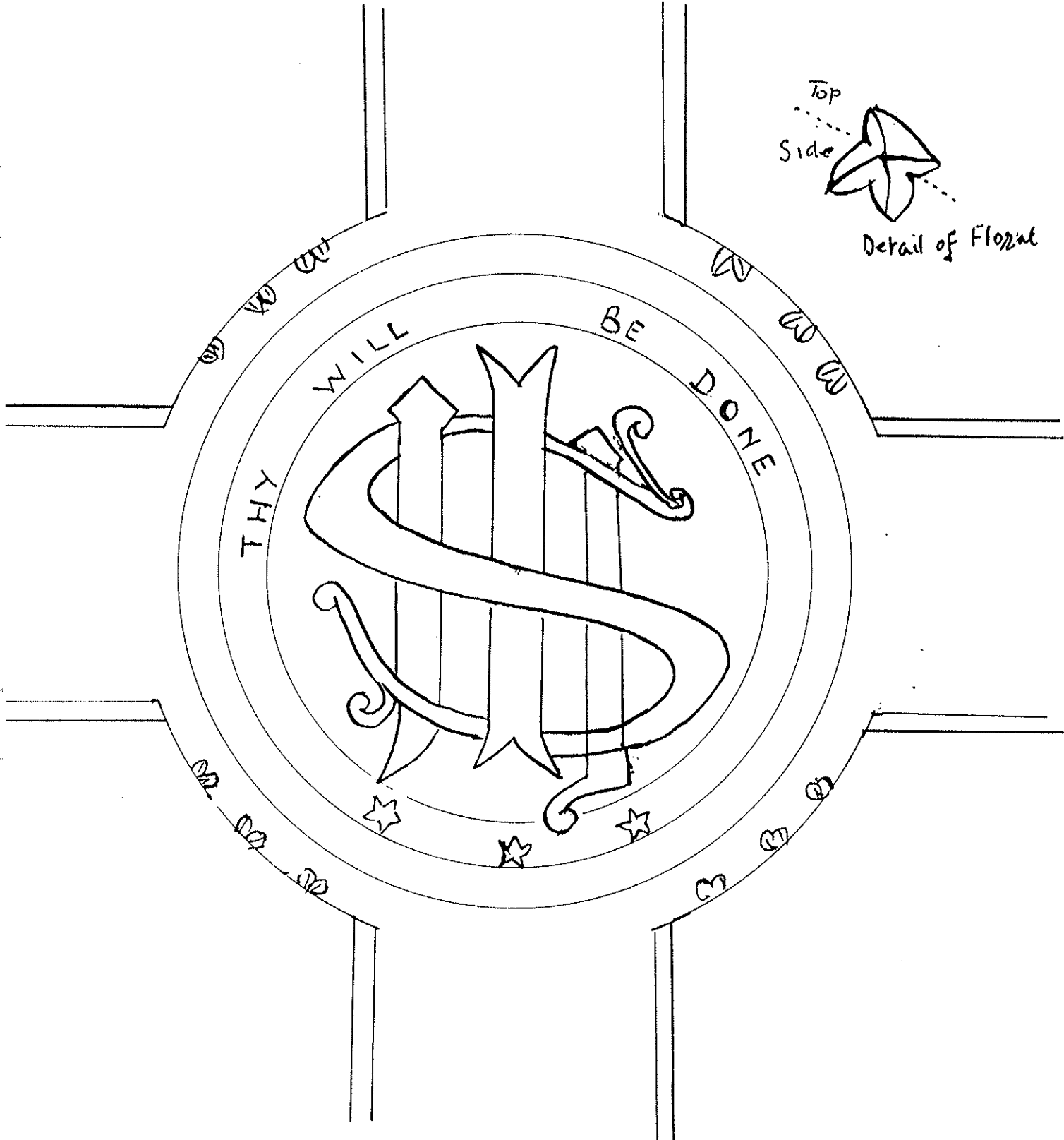

SIR ARCHIBALD PAUL BURT
30-311

PLATE 45

GEORGE LEAKE
30.304 B
END VIEW OF
SCROLL
(IVY)
WHITE MARBLE

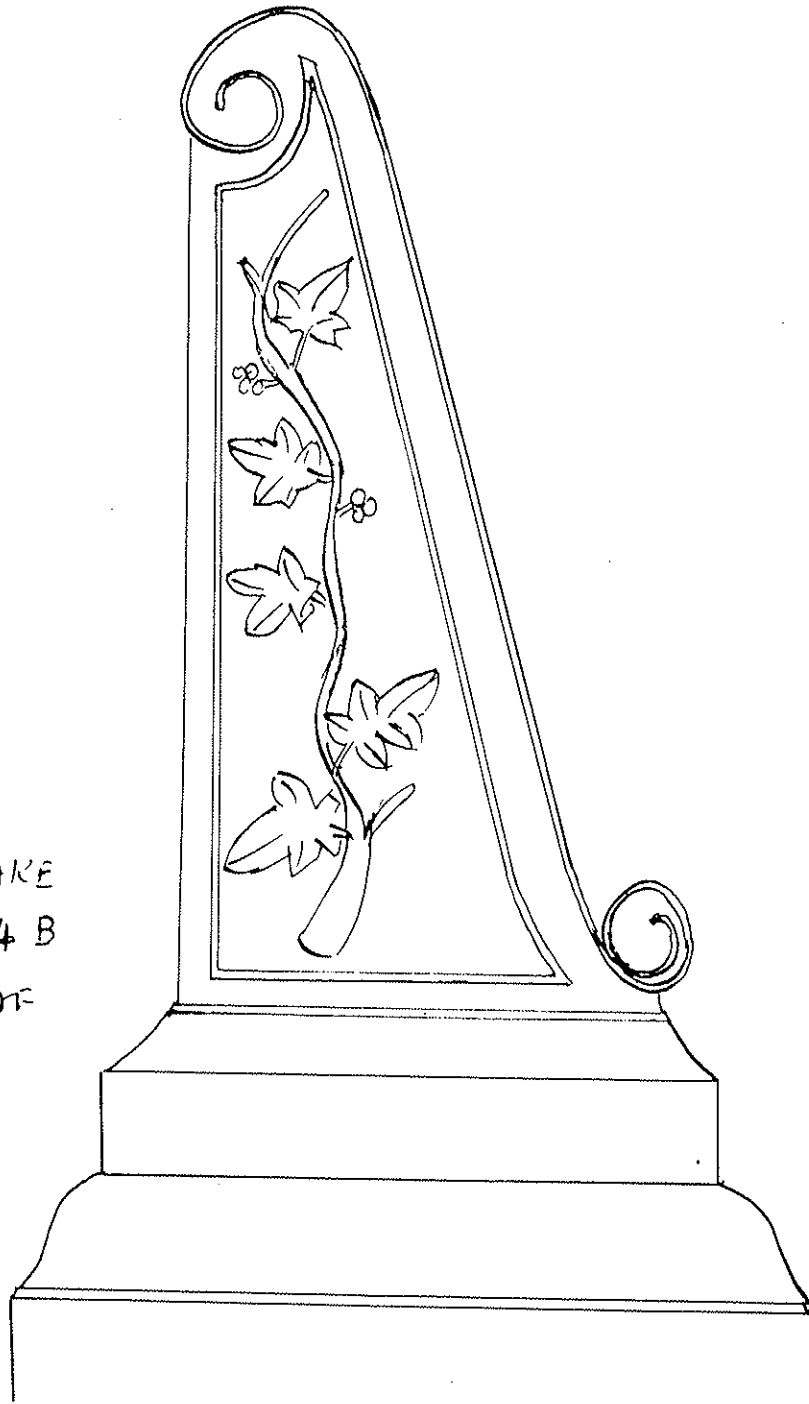

CROSSES, SLAB & LEDGER

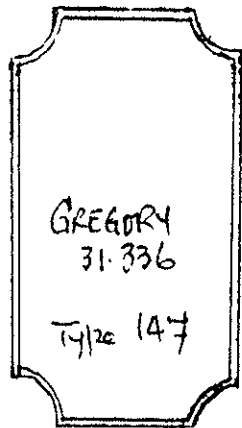
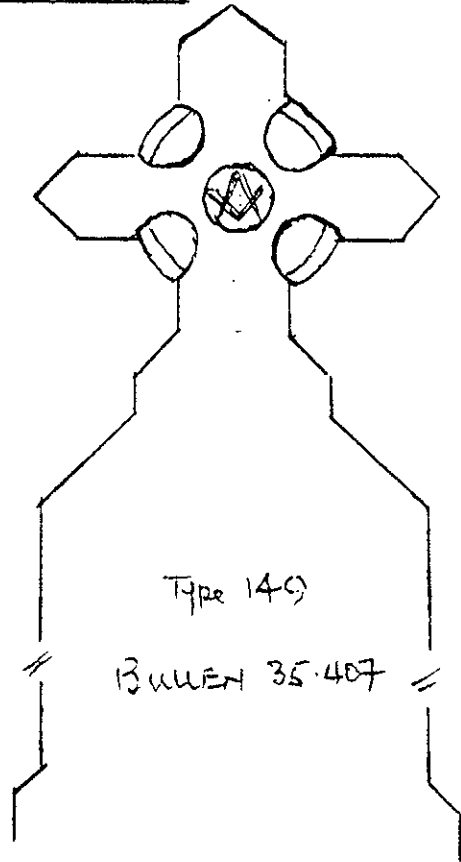
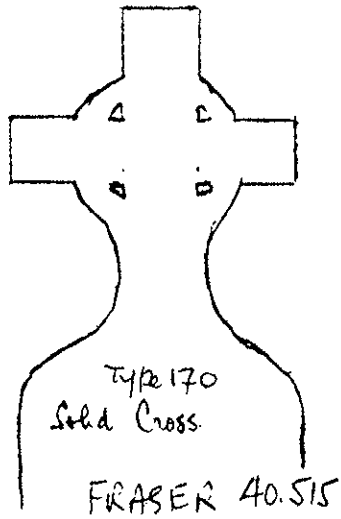

Ledger

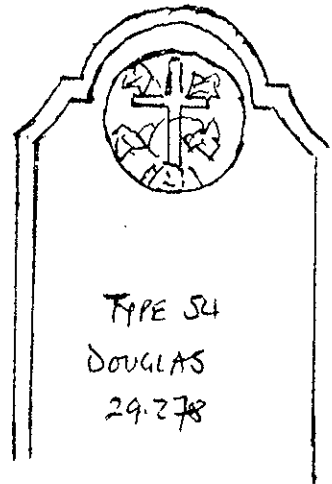
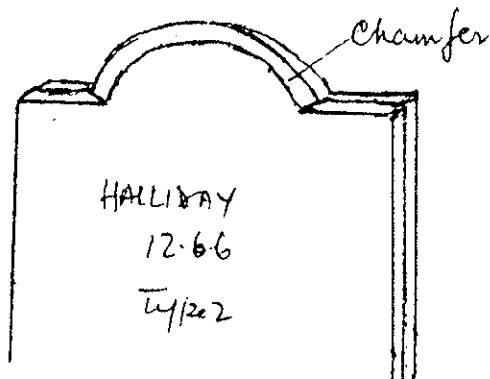

NORMAN & GOTHIC SLABS

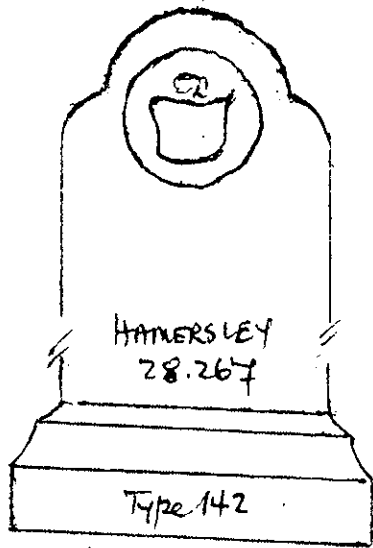

Motto "Honore et Amore"
3 goats on Shield
Winged Horse Supra



DYSON
13.78

Type 130

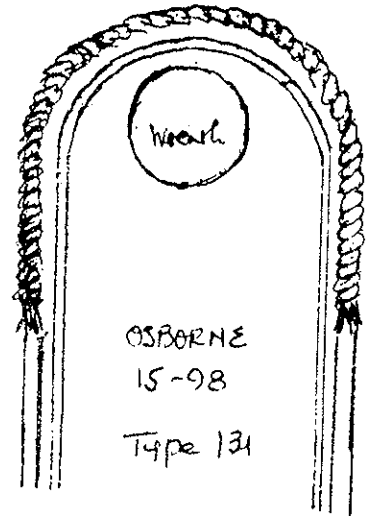

OSBORNE
15-98

Type 131

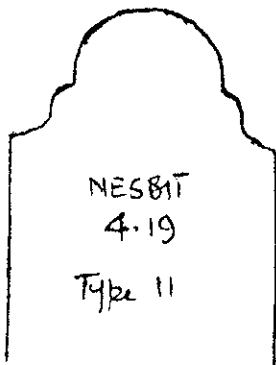

NESBIT
4.19

Type 11

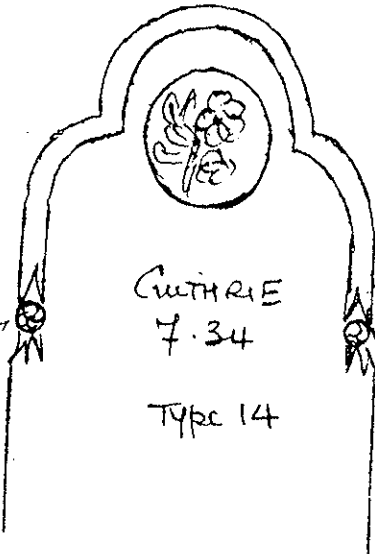

CUTHRIE
7.34

Type 14

Rose

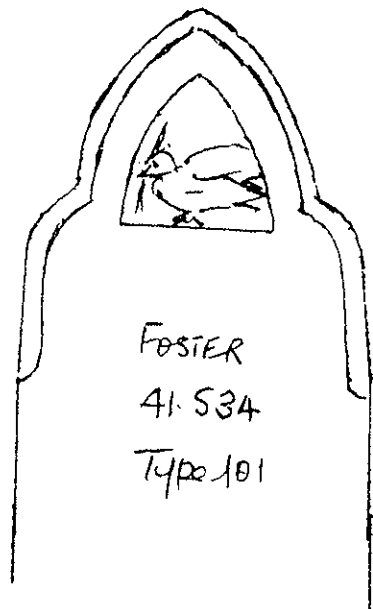

FOSTER
41.534

Type 101

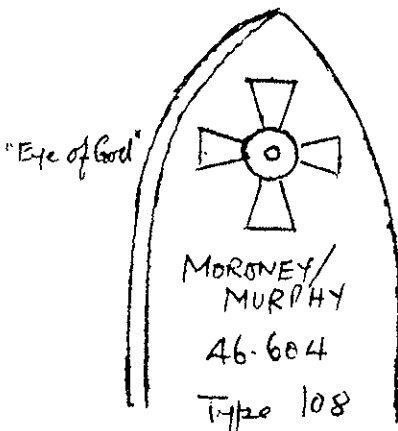

"Eye of God"

MORONEY/
MURPHY

46.604

Type 108

CROSSES

SLABS

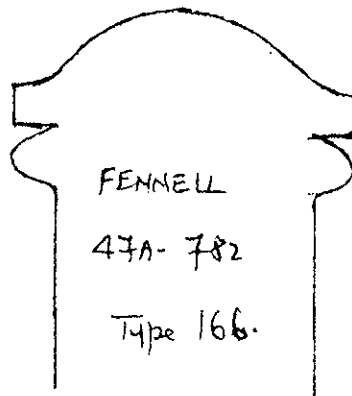
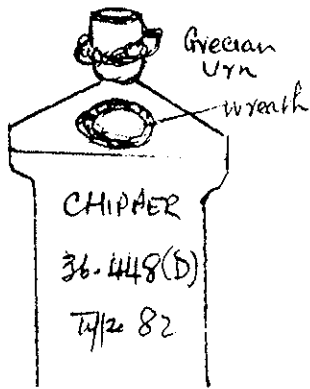
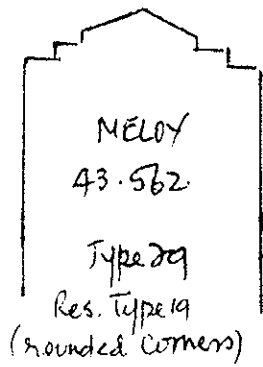
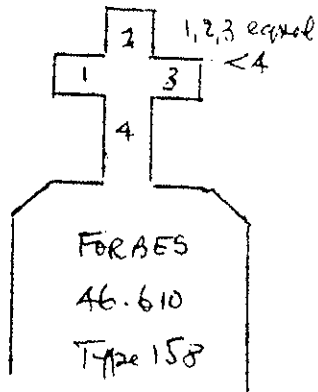
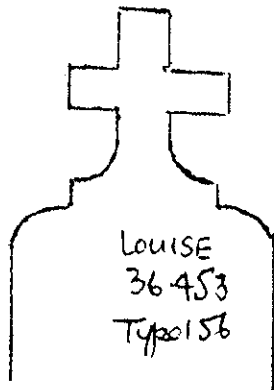
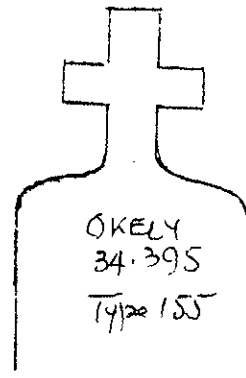
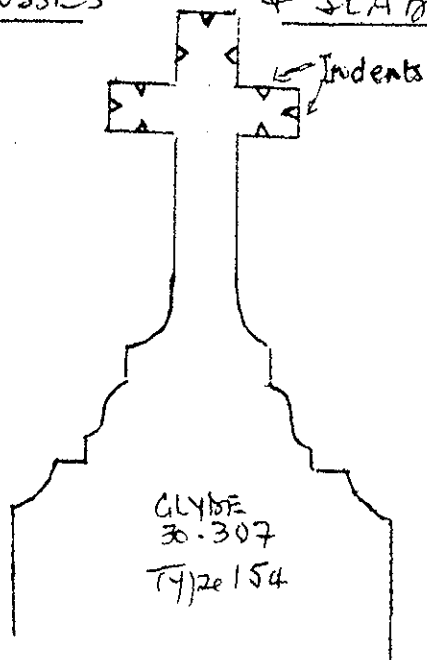
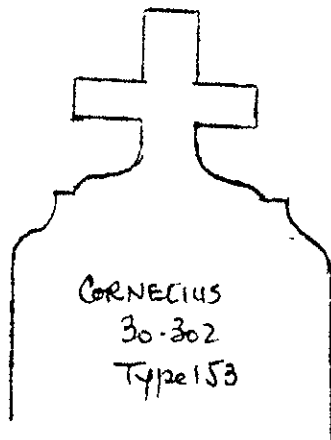

ALTAR + SLABS

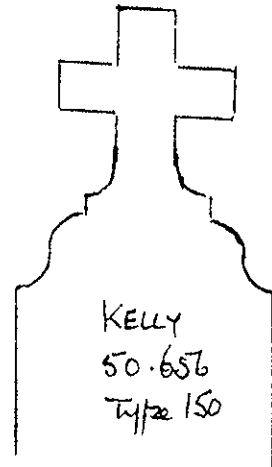
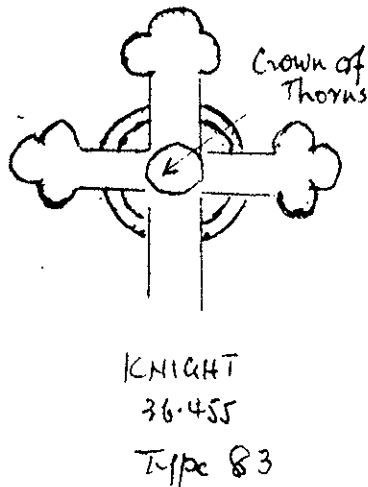
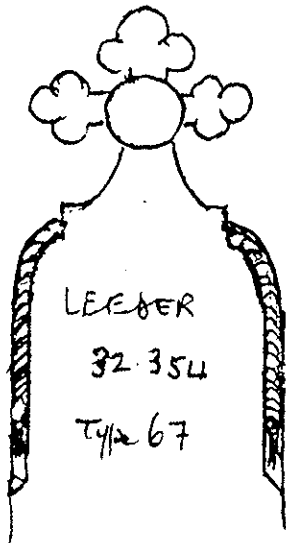
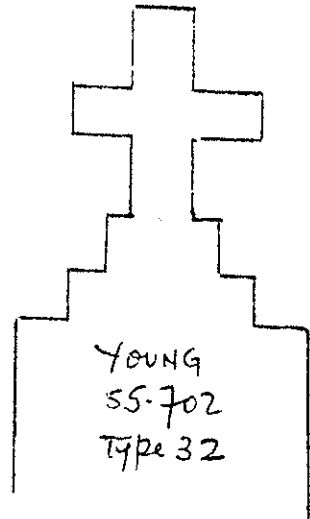
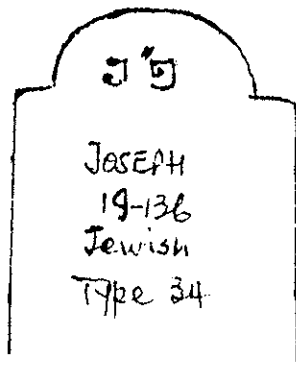
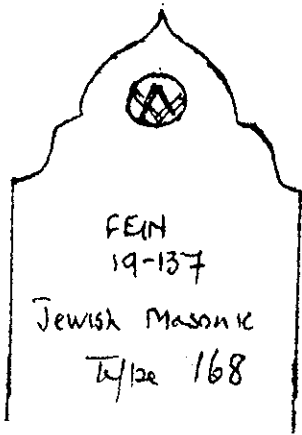
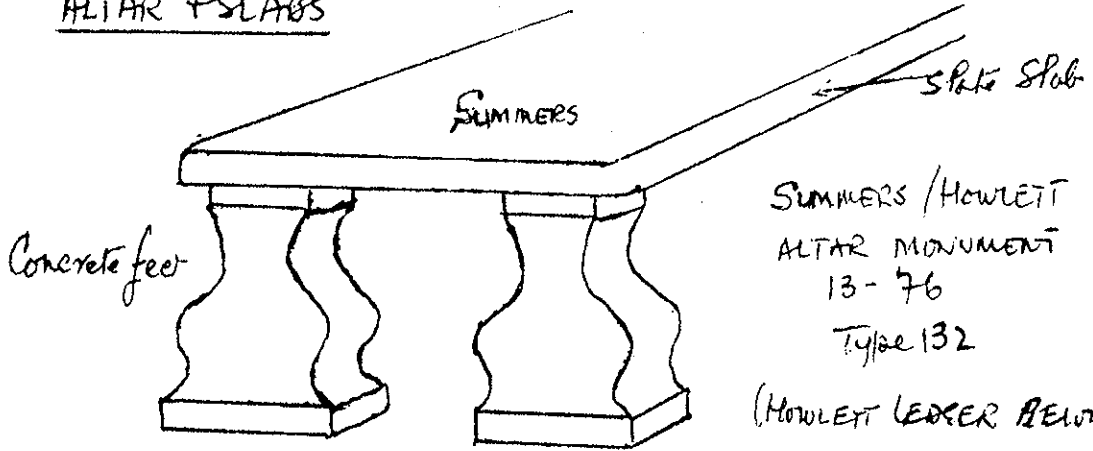

HEADSTONES + PANELS

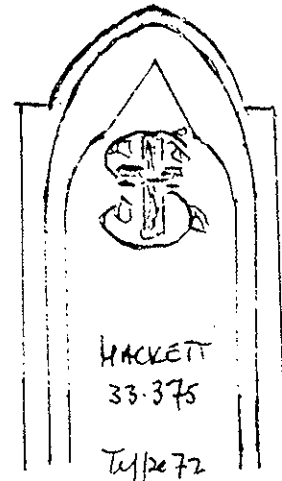
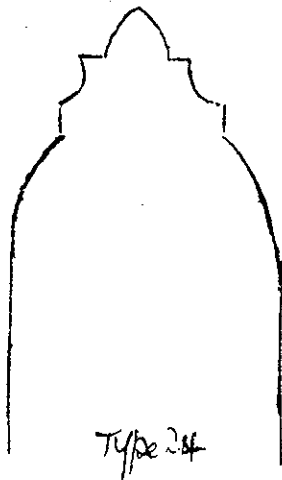
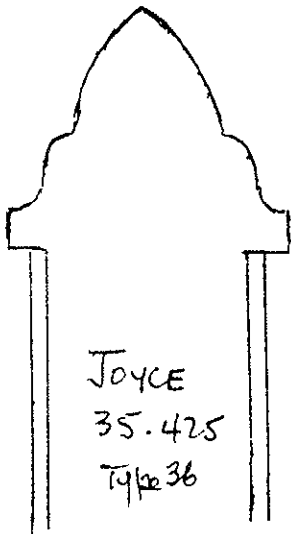
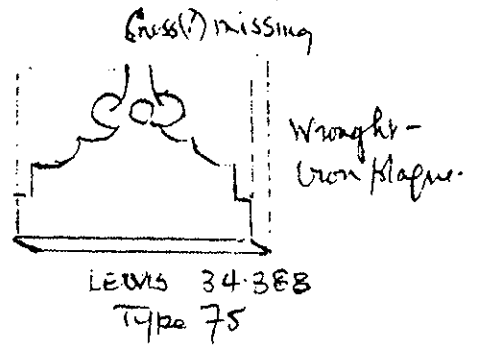
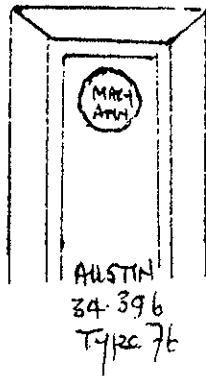
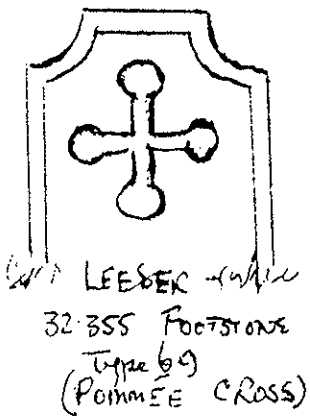
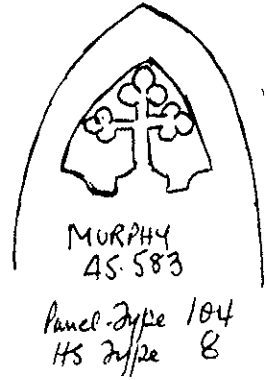
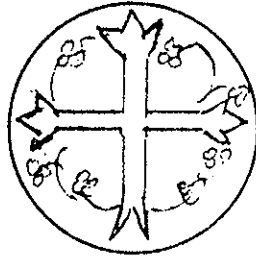
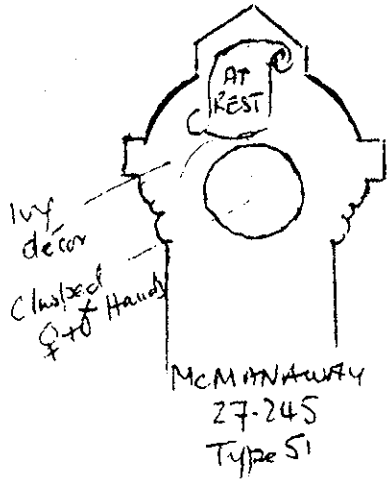

HEADSTONES

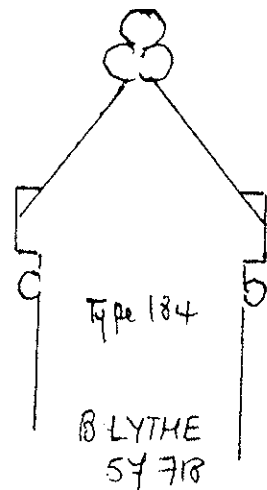
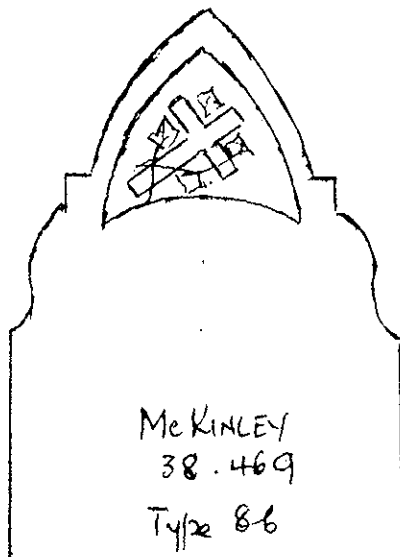
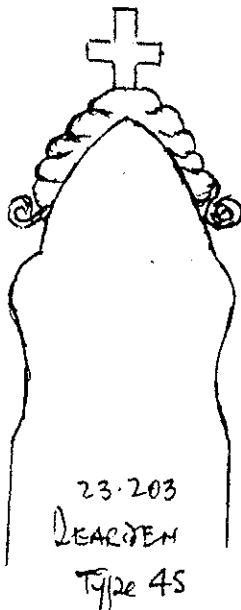
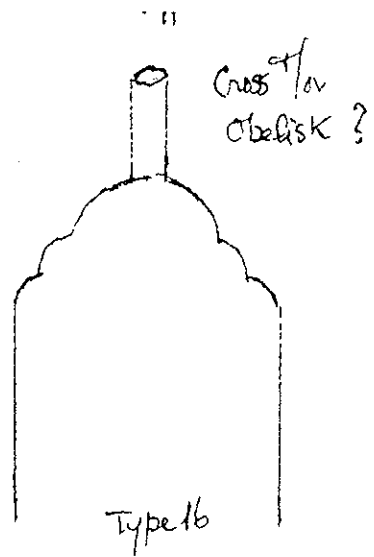
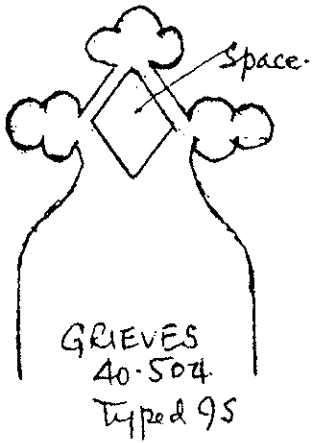
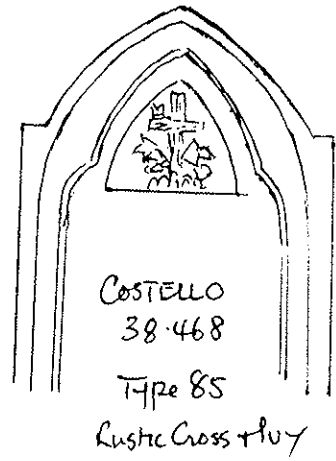
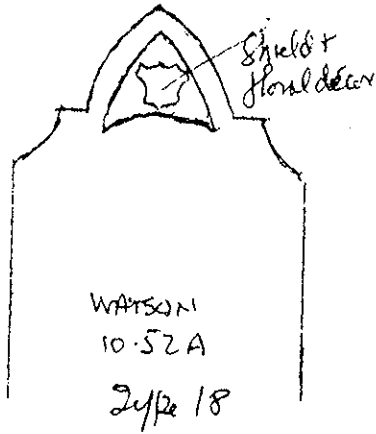
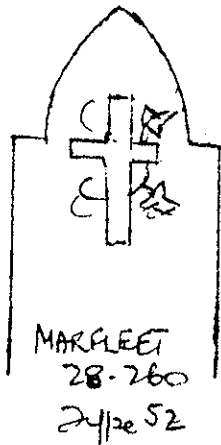

LEDGERS, SCROLL, CROSSES

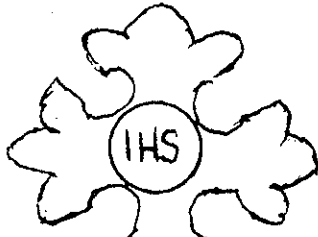

HEADSTONE
Type 94A
PARRY 40-502

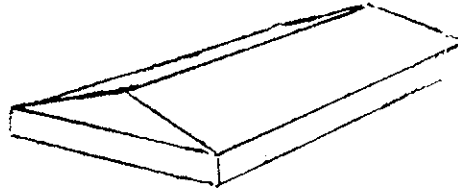

DRIFFIELD 57-723
Ledger Type 125

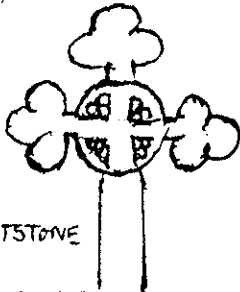

FOOTSTONE
PARRY 40-502
TYPE 94B

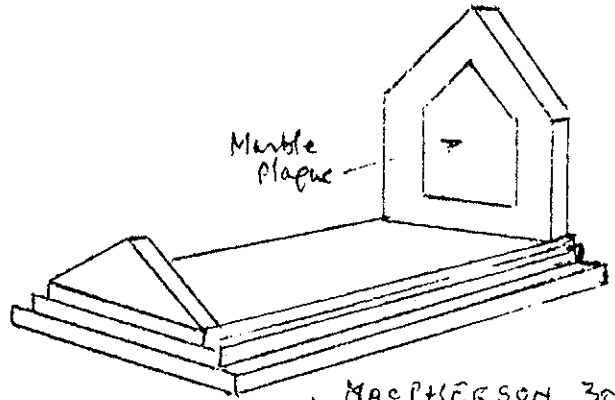

MACPHERSON 30-309
9-tier Ledger with HS + FS
Type 59

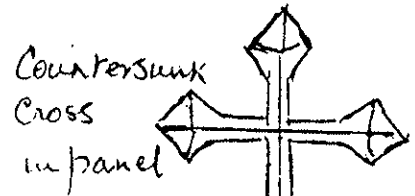
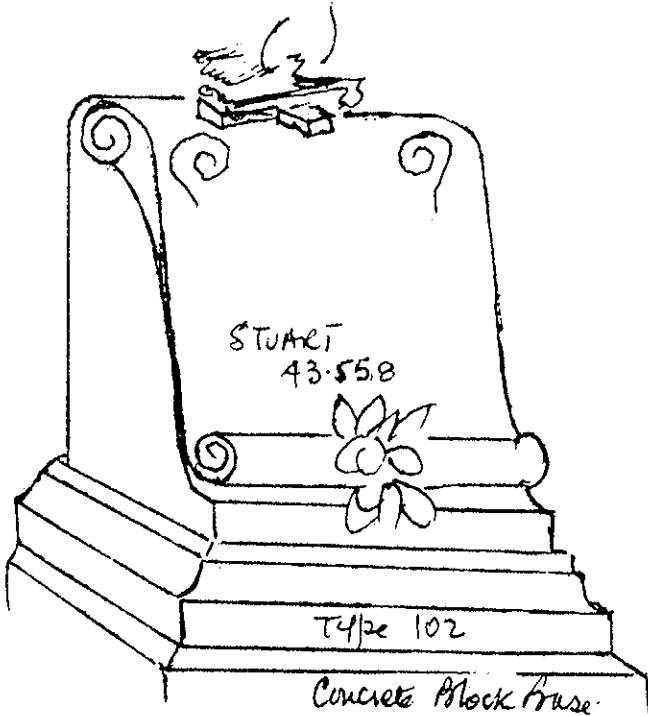

LOWE KEEVIL
48-681
Type 160



Head Missing
Wings
Cross Anchor
Dove
atop Scroll

HEADSTONES, PLAQUE, DECOR

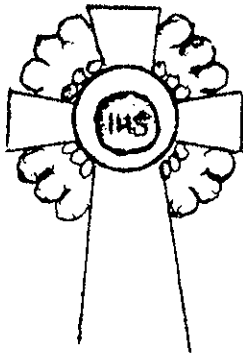

CHAPPEL 36-446

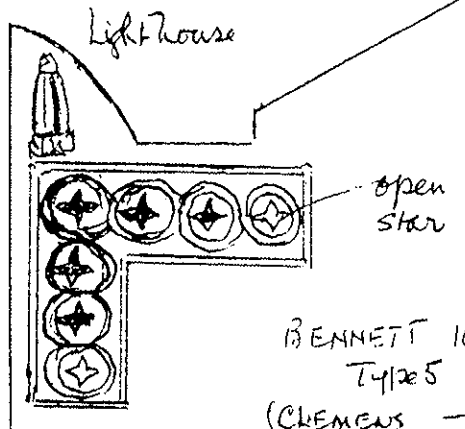

BENNETT 10-524
Type 5 (vide Plate 4)
(CREMENS - MASON)

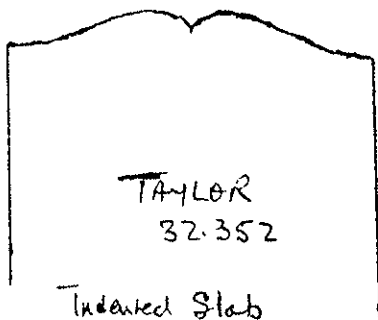

Indented Slab

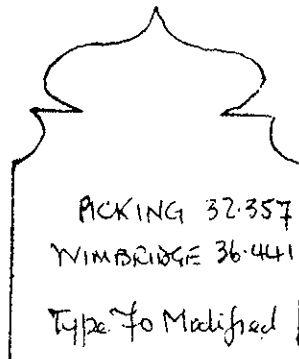

Type 70 Modified

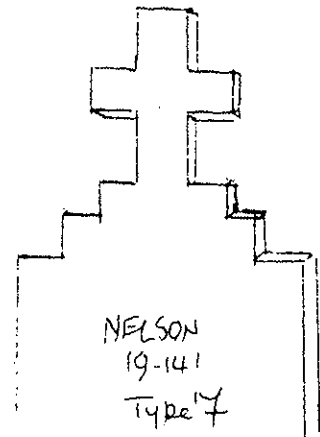

Type 7

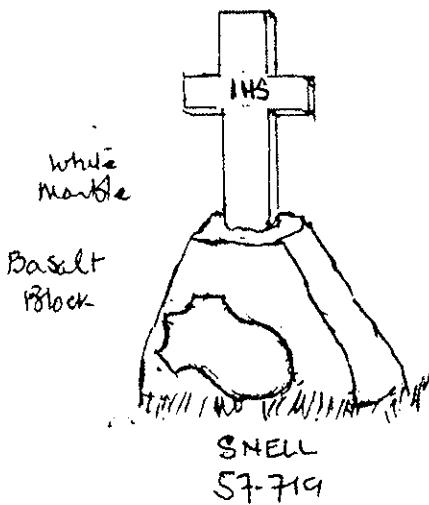

White
Marble

Basalt
Block

SMELL
57-719

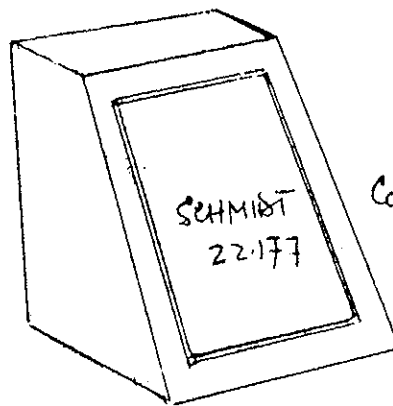

Concrete
Block
White-Marble
Plaque
Type 173

HEADSTONES

(Wm?) Cross missing

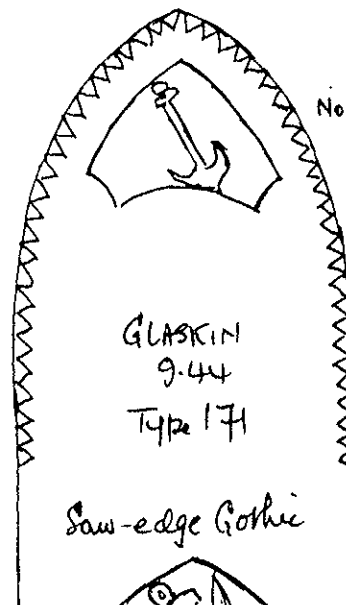
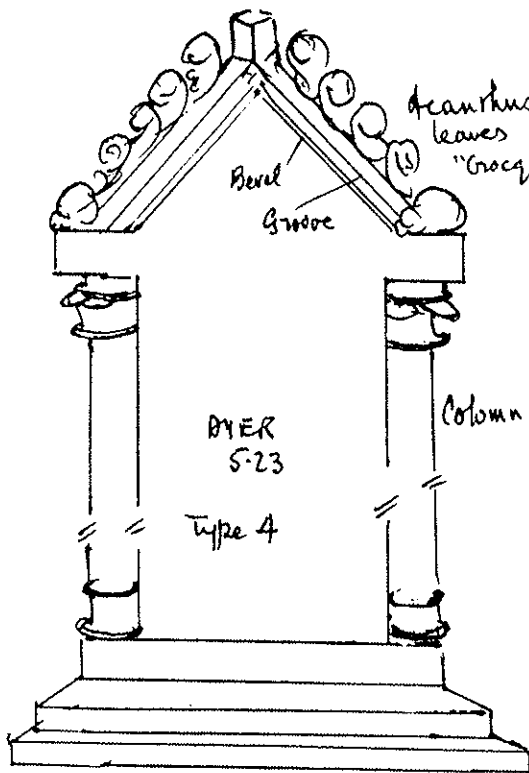

No Rope to Anchor

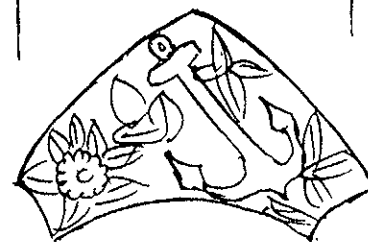

Hooked Anchor

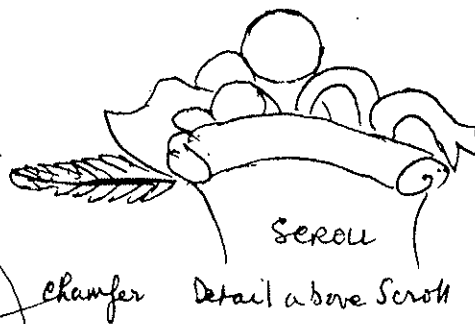
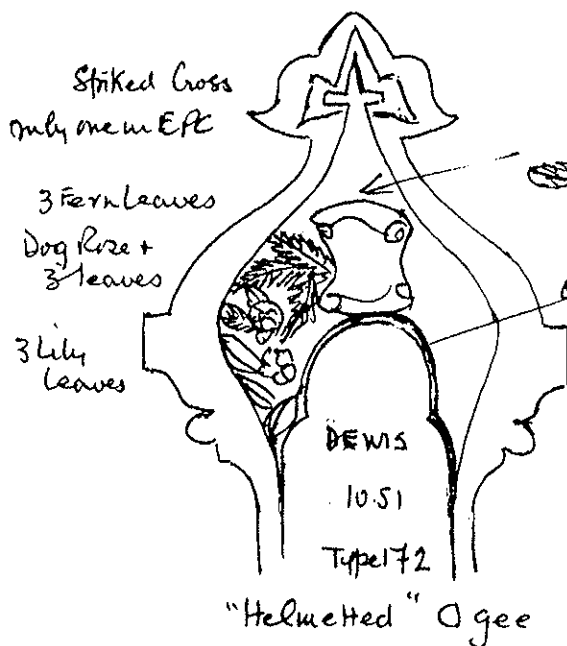

HEADSTONES

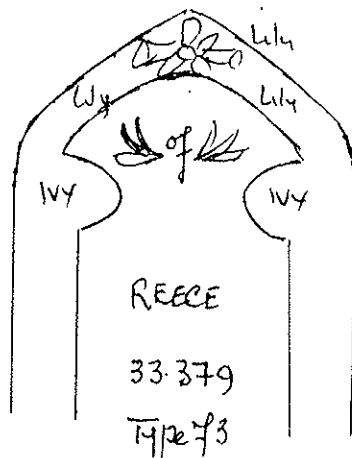
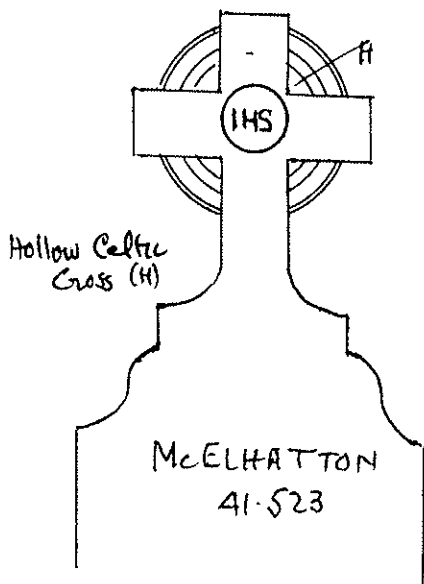
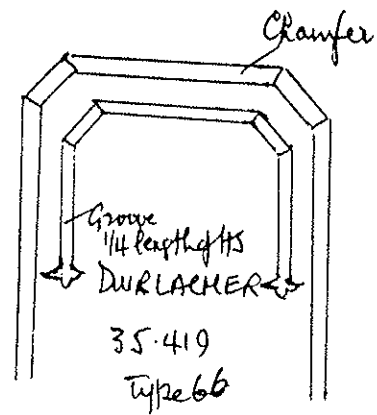
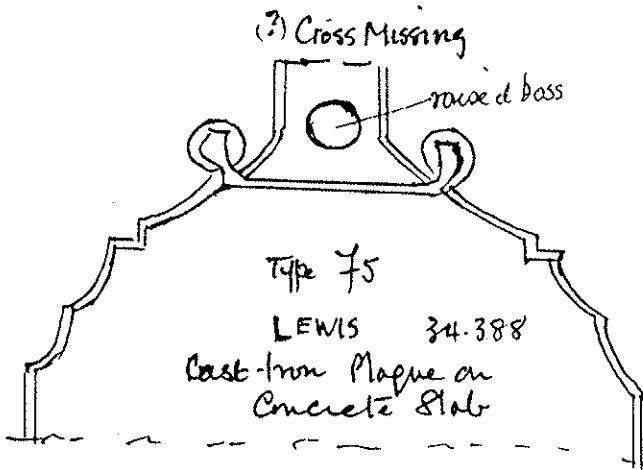
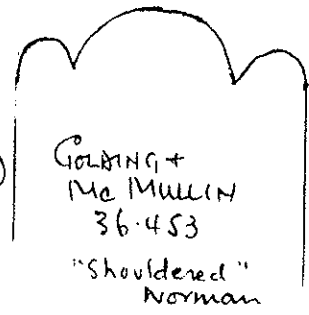
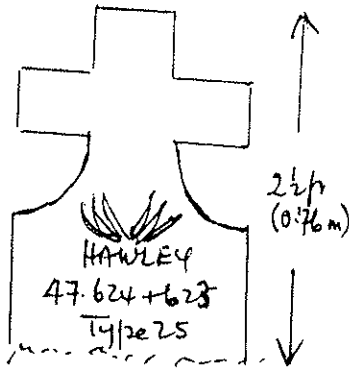
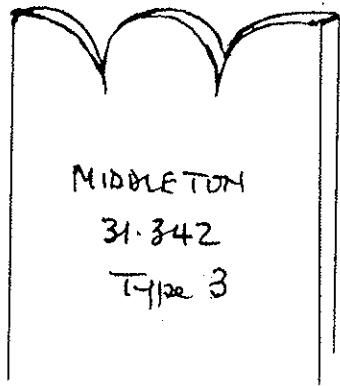
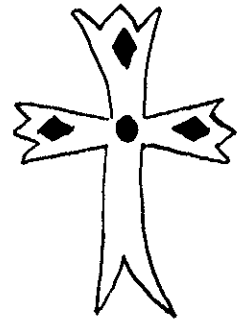
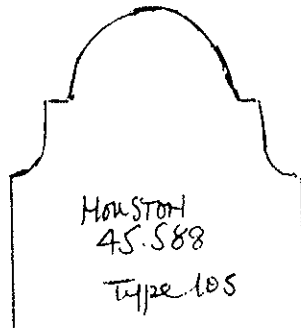
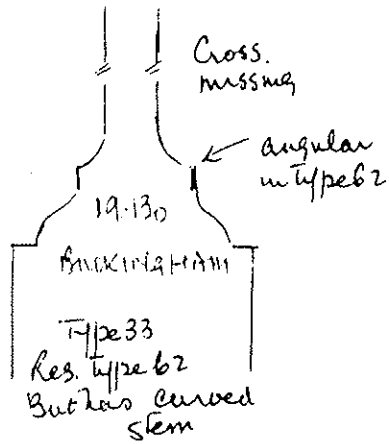
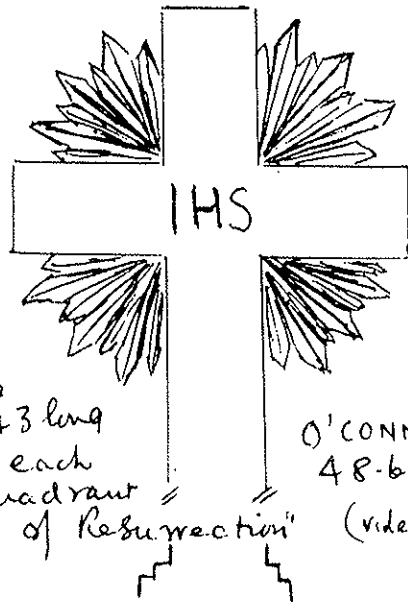
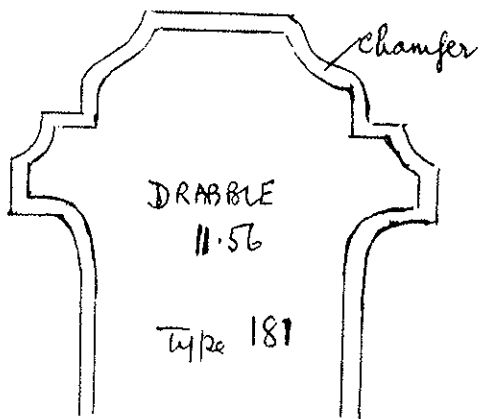

PLATE 56



Avellan Cross on HS
CURTAIN
48.636



Sunrise
4 short + 3 long
rays in each
quadrant
"Dawn of Resurrection" (vide Plate 17)
O'CONNELL
48.638

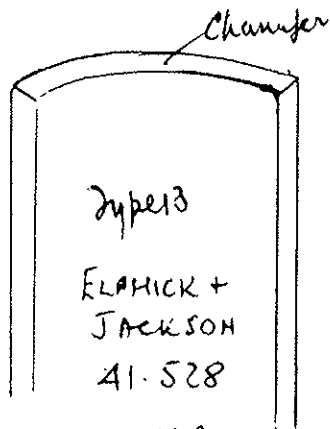

Rounded Oslong

Solid Celtic
Cross

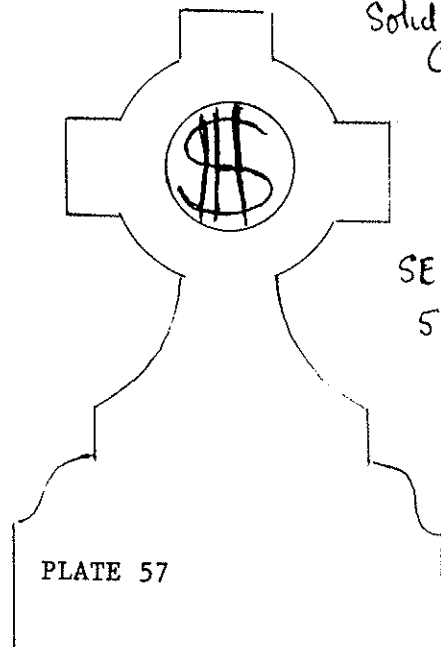

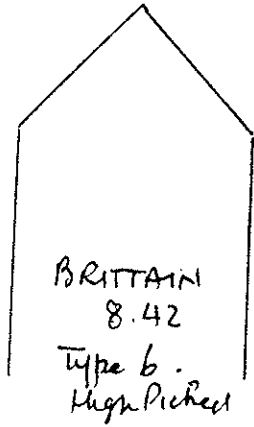

BRITTAIN
8.42
Type 6.
High Picket

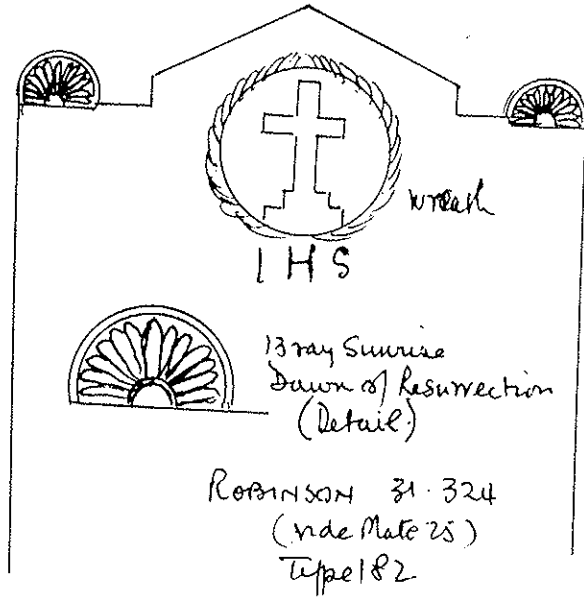

wreath
IHS

13 ray Sunrise
Dawn of Resurrection
(Detail)

ROBINSON 31.324
(vide Plate 25)
Type 182

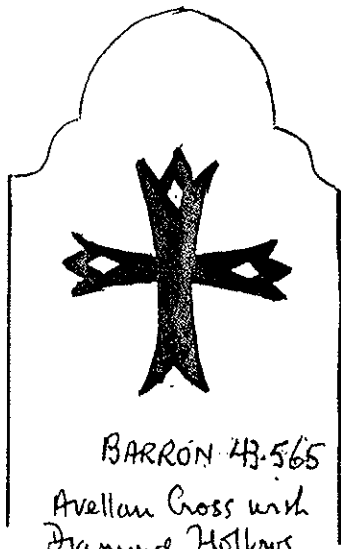

BARRON 43.565
Avellan Cross with
Diamond Hollows
Type 192.

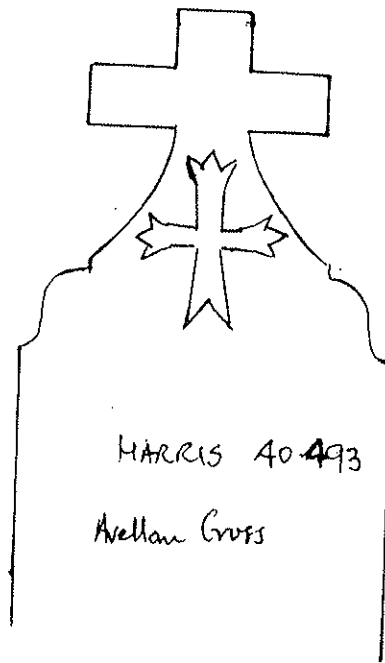

HARRIS 40.493
Avellan Cross

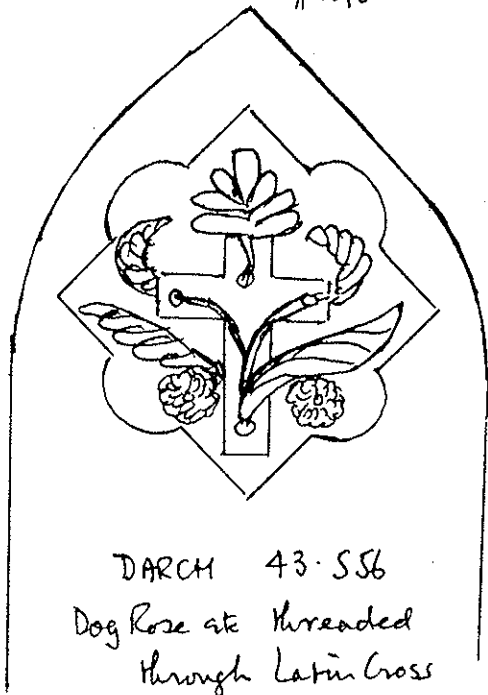

DARCH 43.556
Dog Rose etc threaded
through Latin Cross

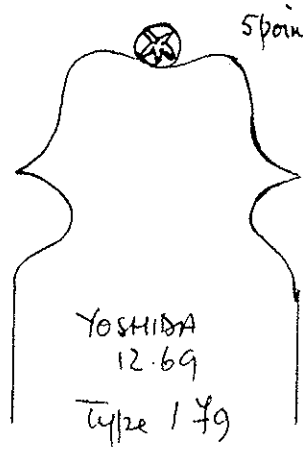

5 point star

YOSHIDA
12.69
Type 179
Only 43 of this form in EPC

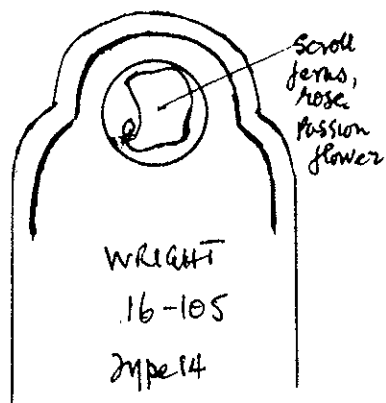
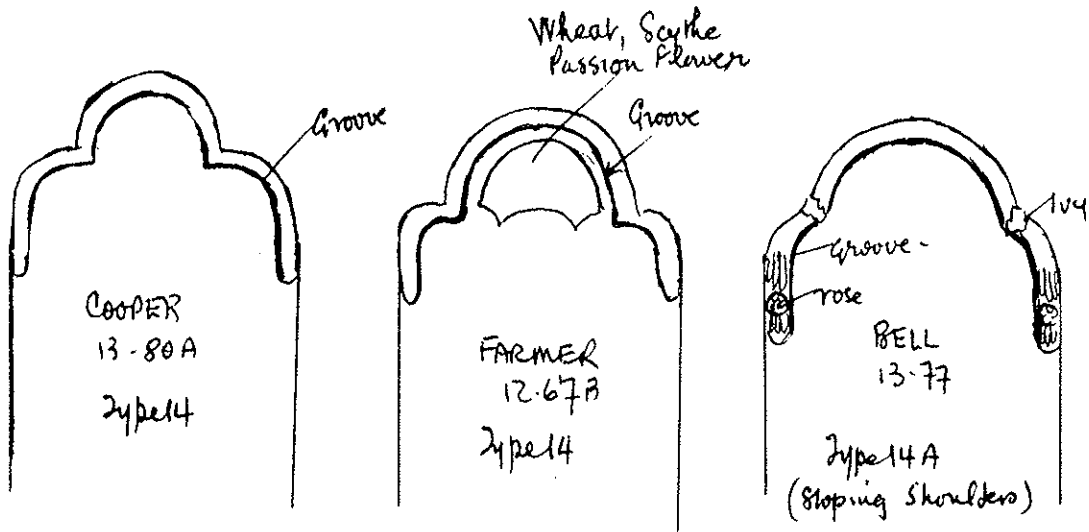

VARIATIONS ON "SHOULDERED"
NORMAN SLABS: ONE
IMPRESSION OF BEING ANTHROPOMORPHIC

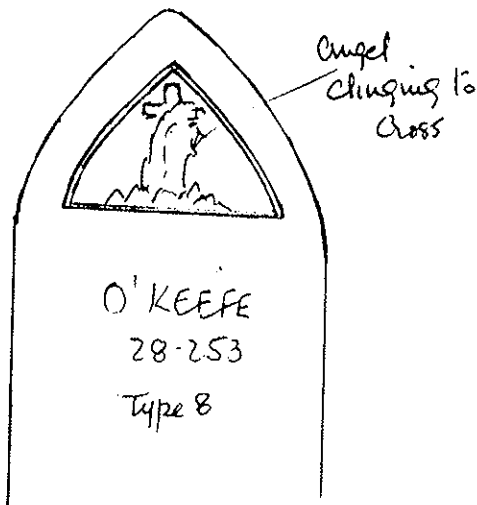
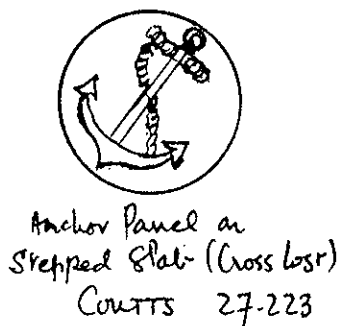
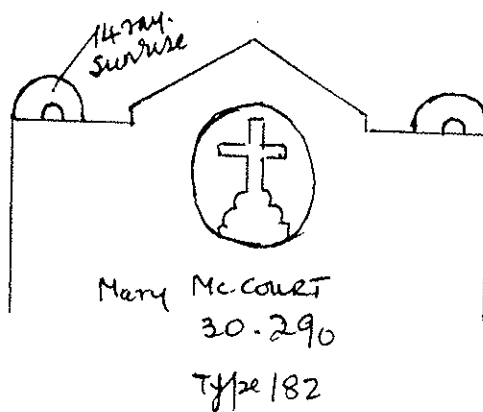

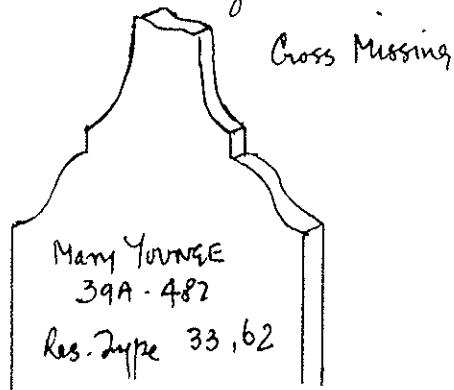
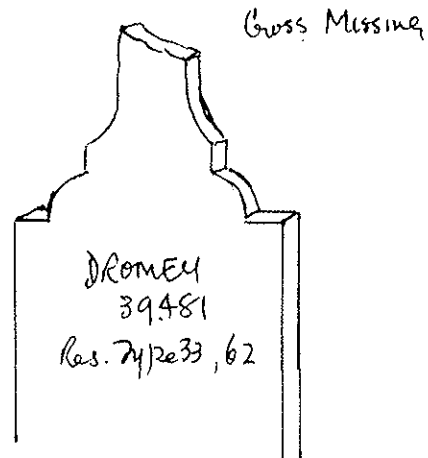
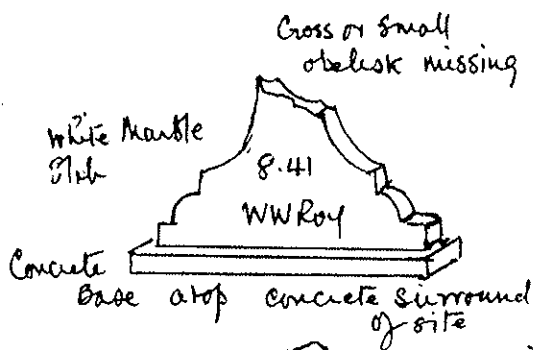
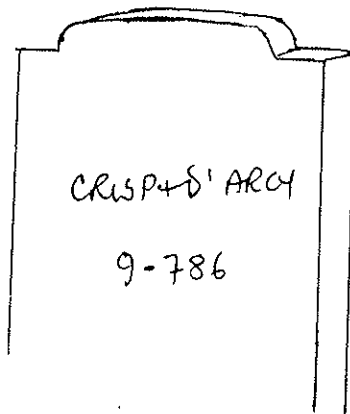
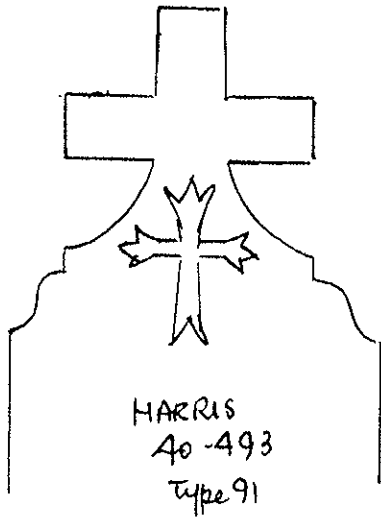
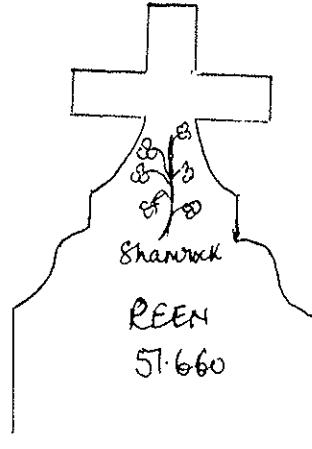
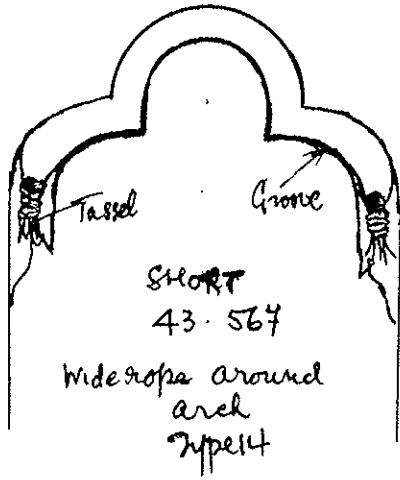

PLATE 60

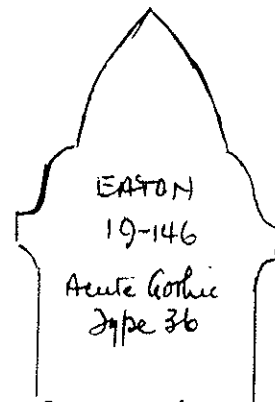
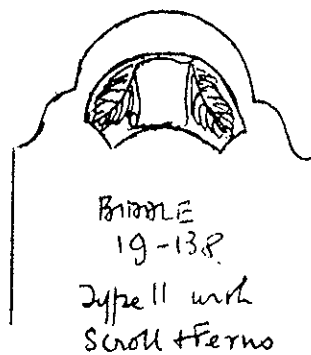
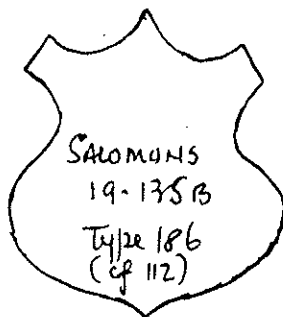
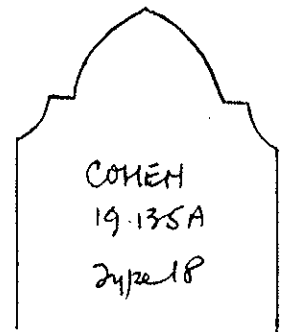
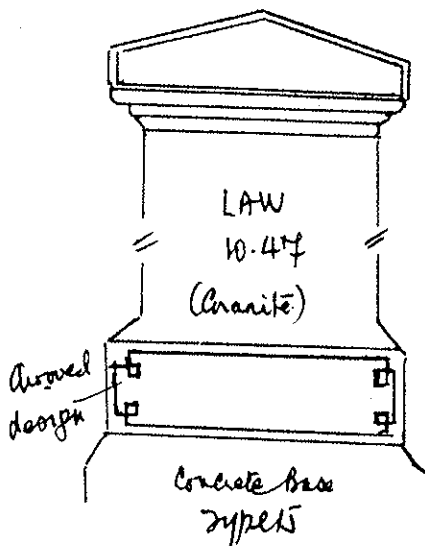
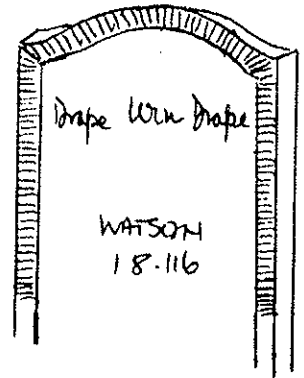
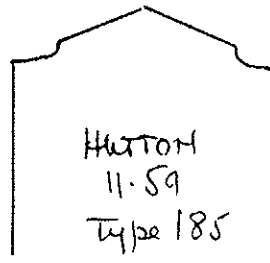
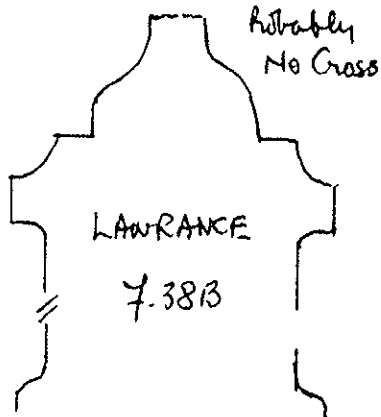
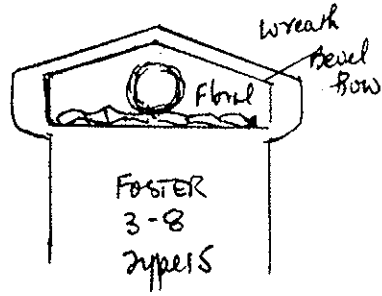
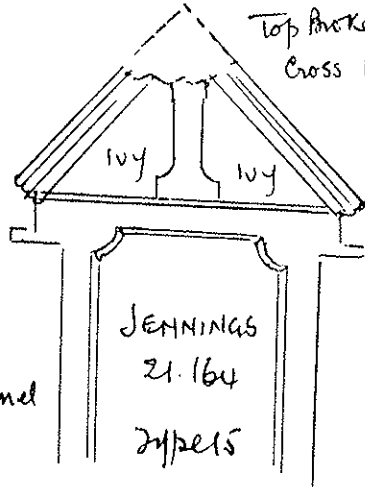

PLATE 61



St. Andrew's
Cross + ivy



Top Broken Off
Cross missing

HS composed
of "Coke -
concrete"

Raised Panel

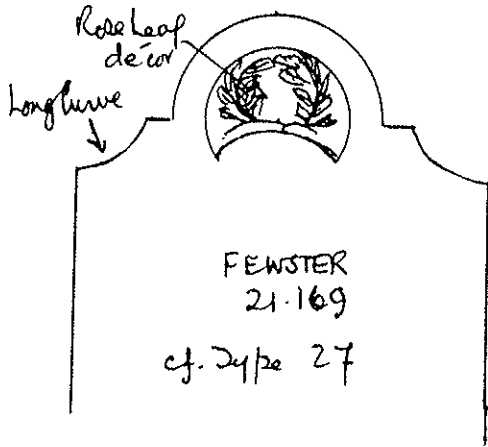

Rose leaf
decor
Long curve

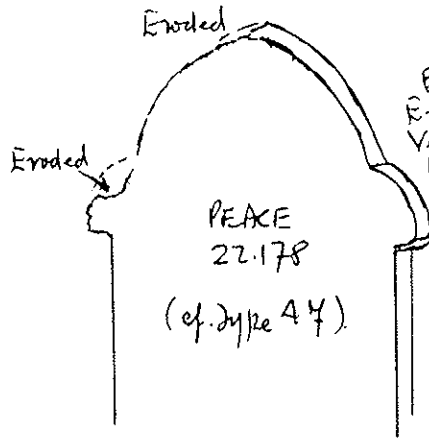

Eroded

Eroded

Badly
Eroded
Veined
Marble
(Poor
Stone)

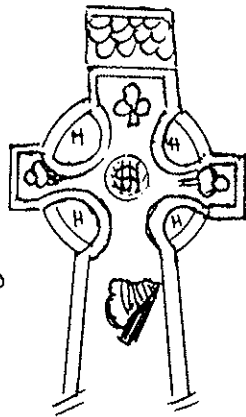

H = Hollow

QUINLAN
22.175A

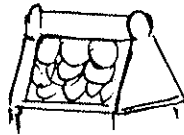

Lych Gate
on 22.175B
CONNOR

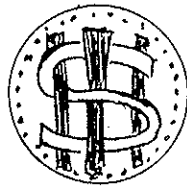

Hollow Celtic Crosses
Capped by Small
Lych Gate.

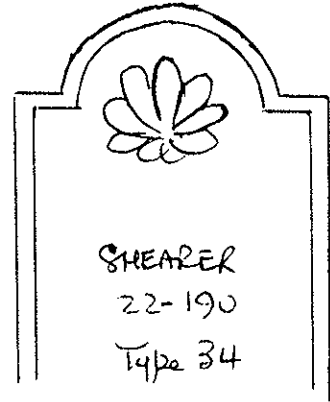
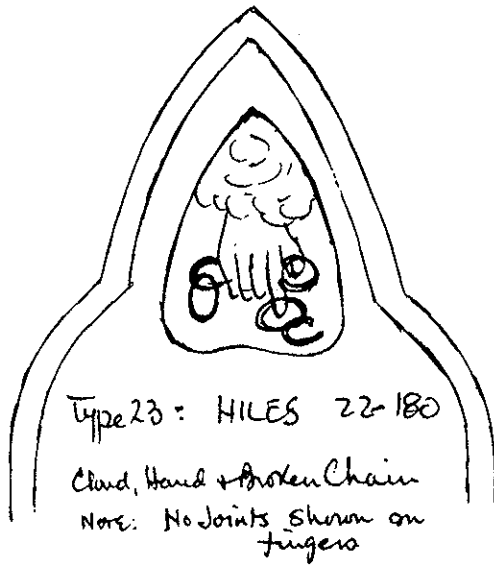

Broken Stem
 Madonna Lily
 on rocks

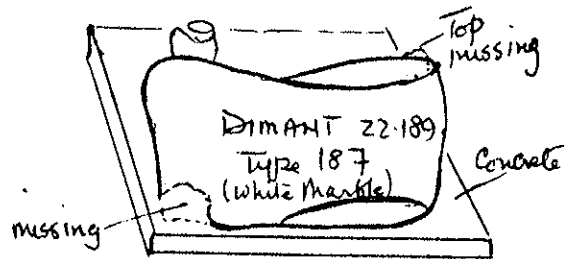
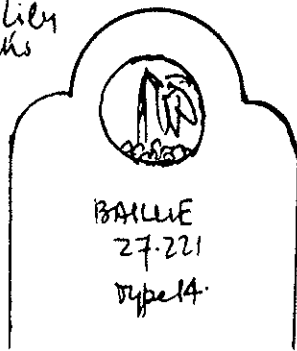

Horizontal Scroll: Only
 one in EPC
 Additional to Gothic H.S. Type 23

Cross Missing

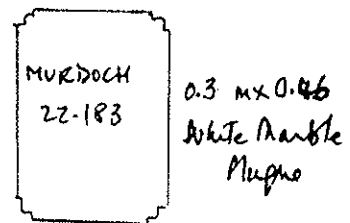
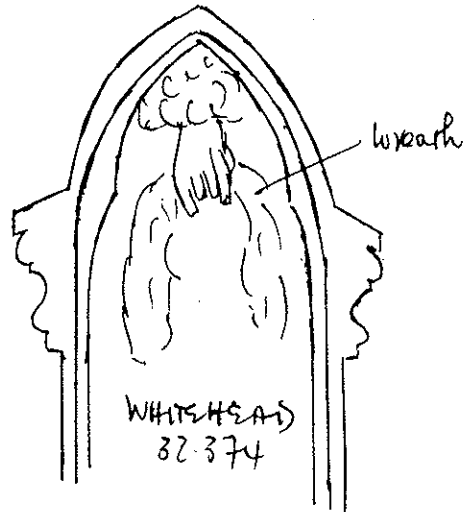
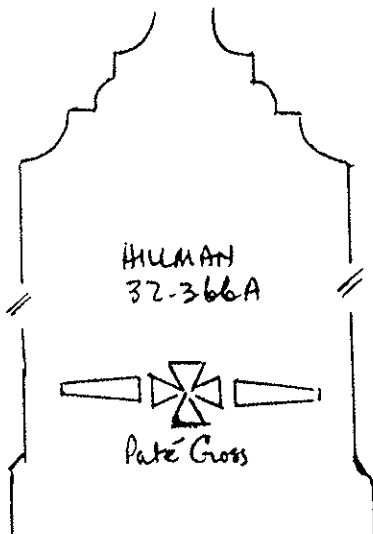

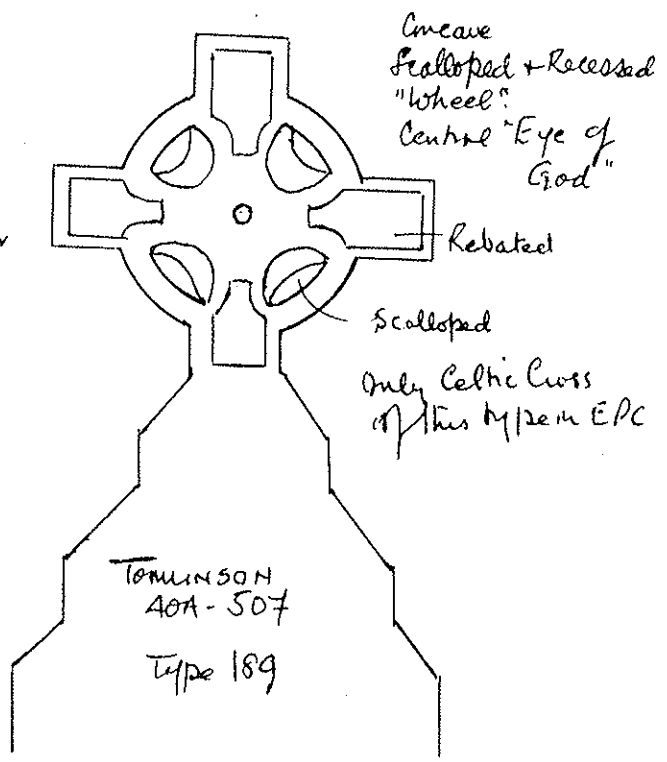
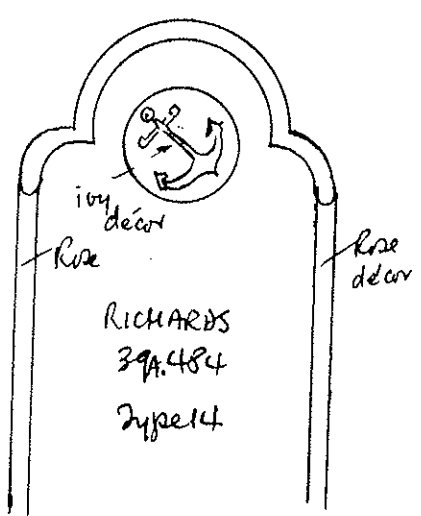
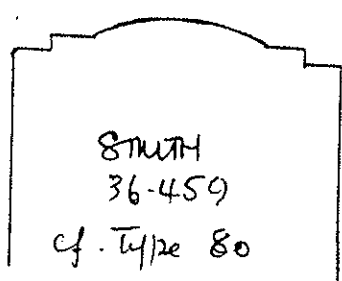
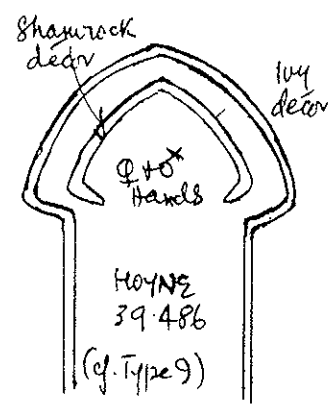
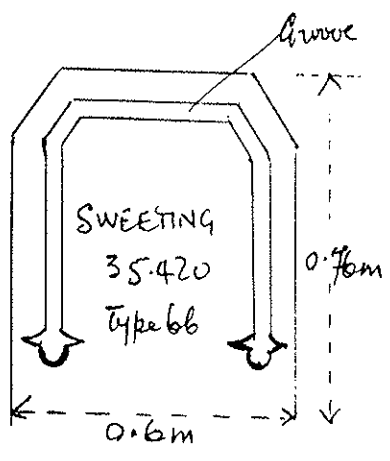
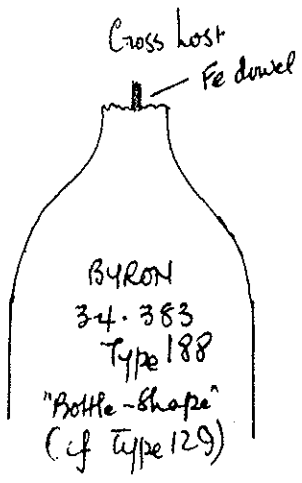
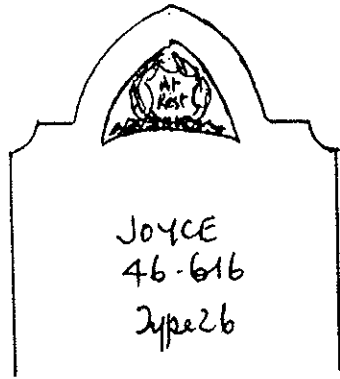
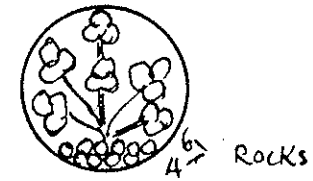

PLATE 64



JOYCE
46-616
Type 26



Shamrock panel on
Cross Type 117
LAMBERT: 49-648

Detail of
Panel
Laurel
wreath

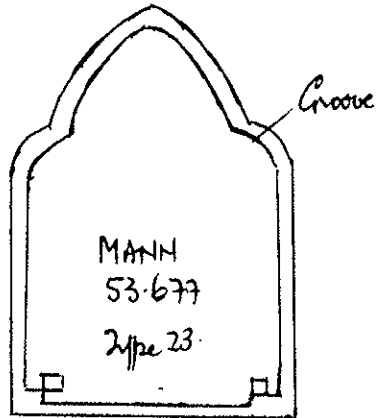
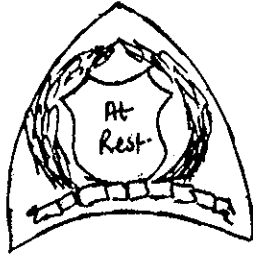

MANH
53-677
Type 23

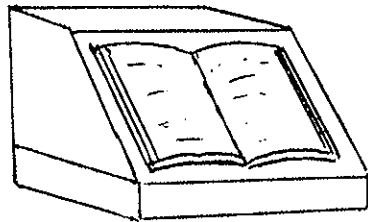

MATLAND 56-686
Book - White Marble on
concrete block

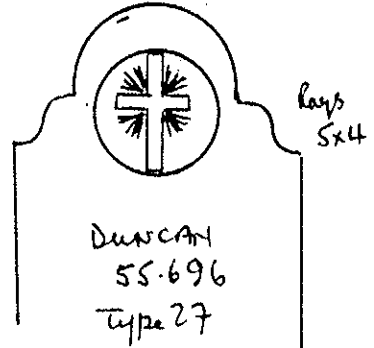

DUNCAN
55-696
Type 27

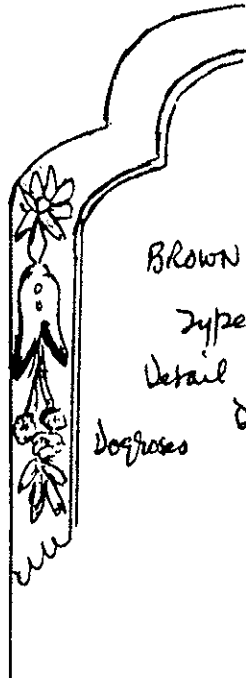

BROWN 59-740
Type 14A
Detail of Floral
Decor

Dog roses

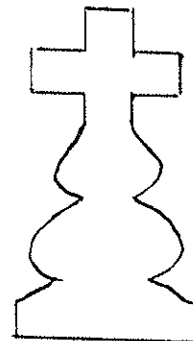

FLOSSIE
STEWART
46-603
(wide Plate 25)

Only H.S. of this type in E.P.C.

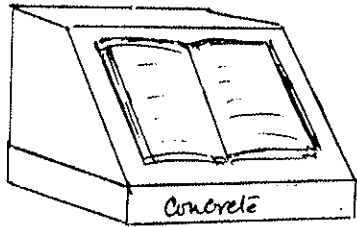

White Marble Book
on Concrete Block
MATLAND 56.686.

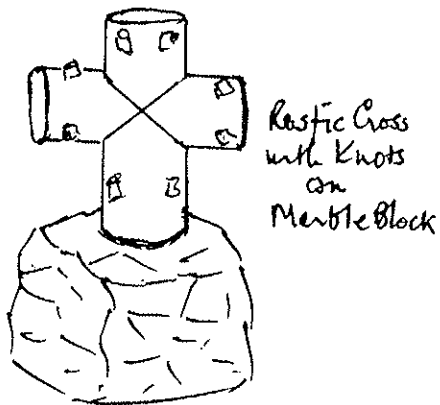
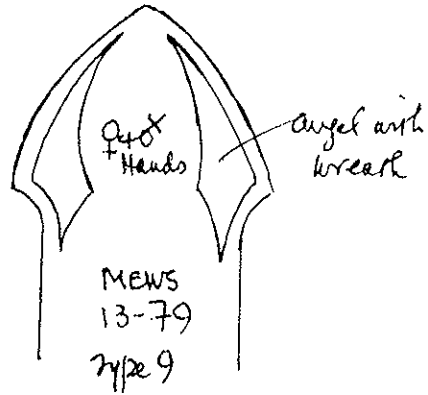

KROSS 13-8013
Type 37

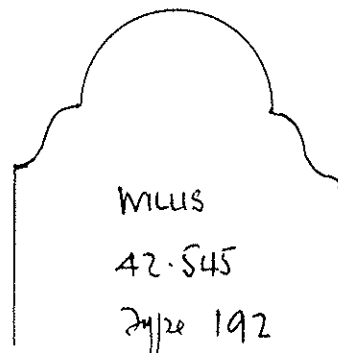
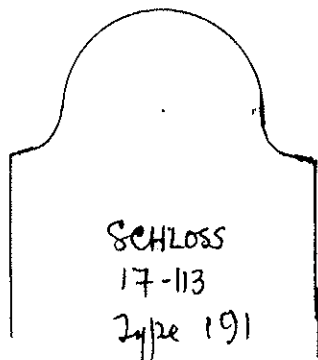
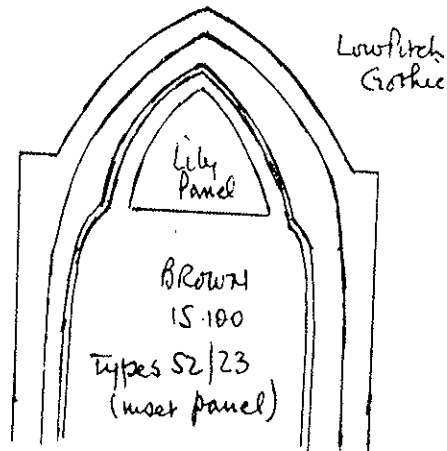
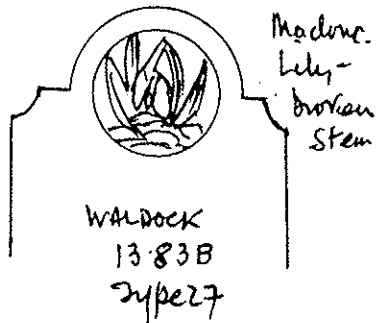
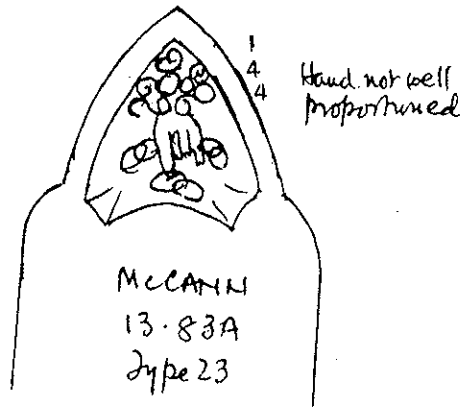

NORMAN SLABS : POPULAR DESIGNS

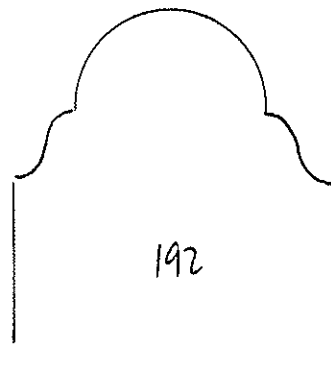
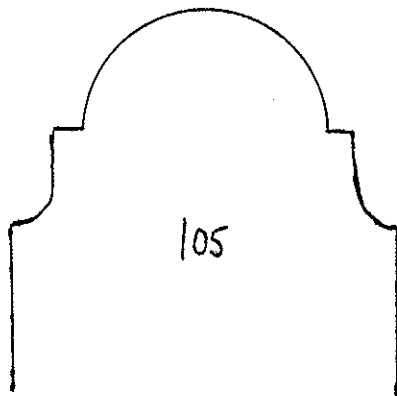
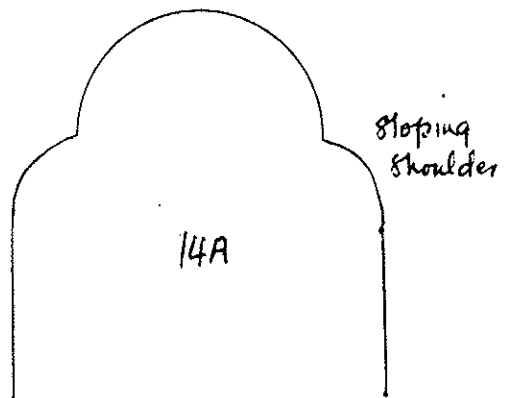
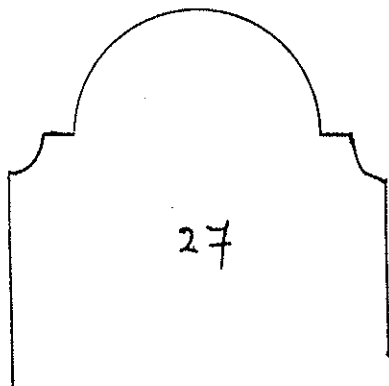
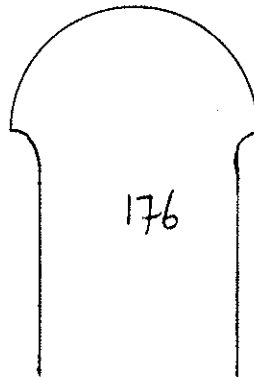
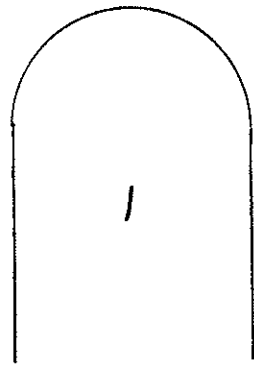
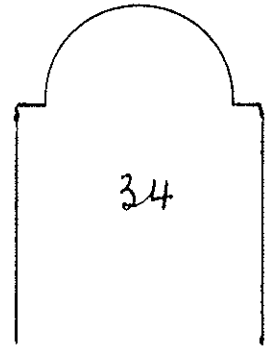
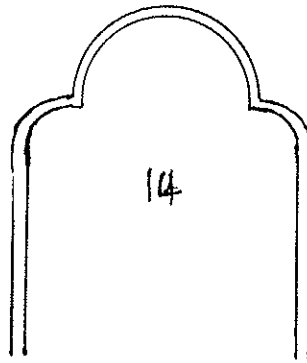
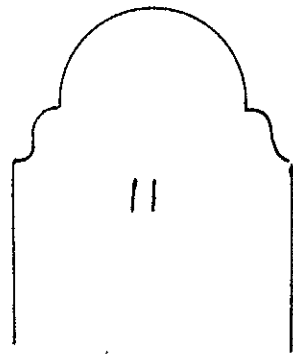

PLATE 67

GOthic SLABS : POPULAR DESIGNS

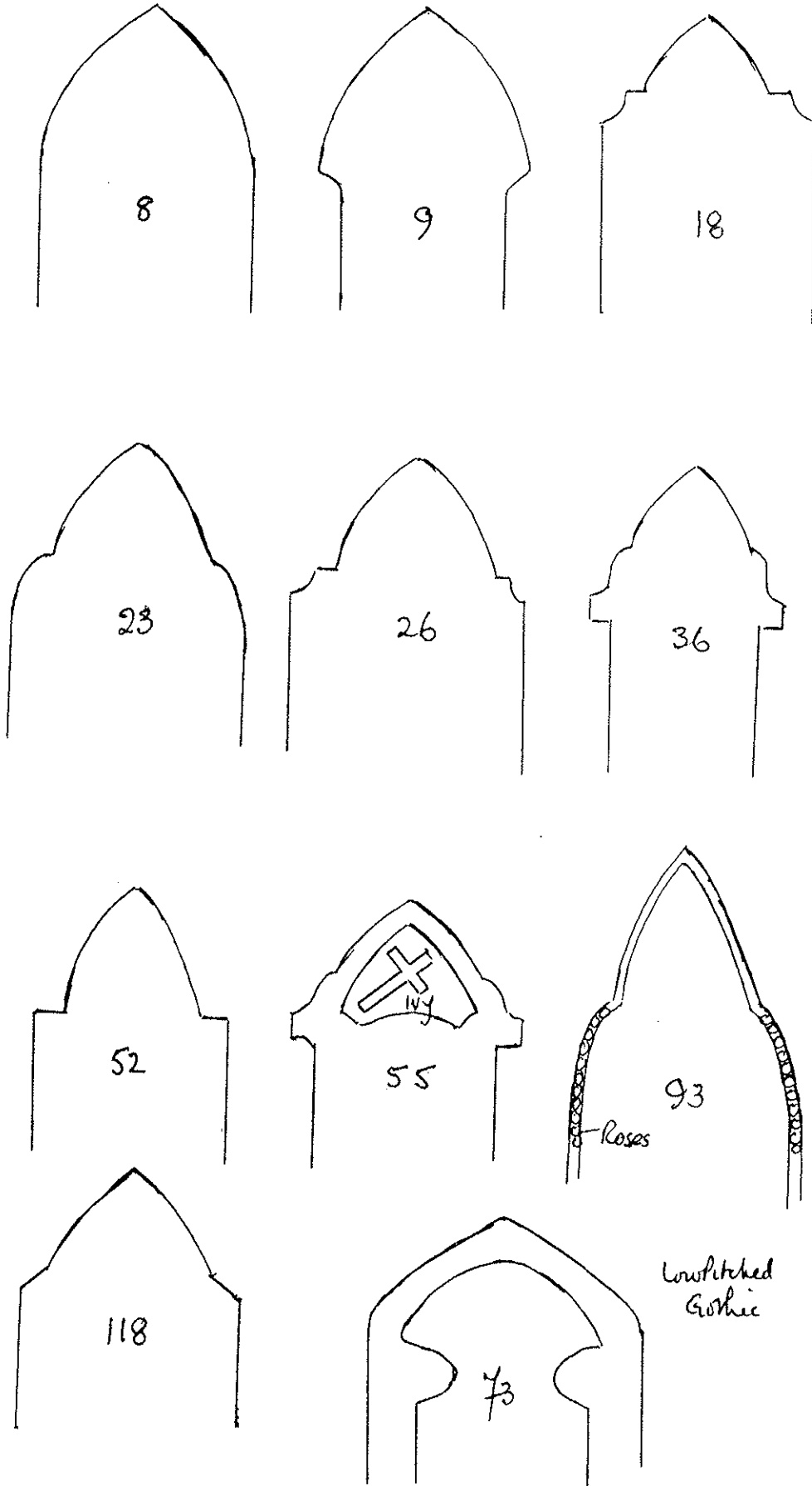

PLATE 68

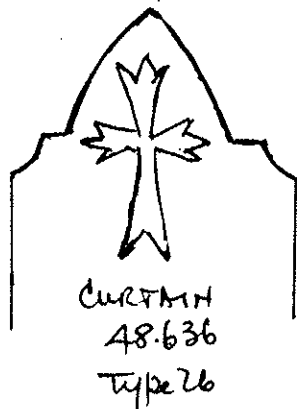
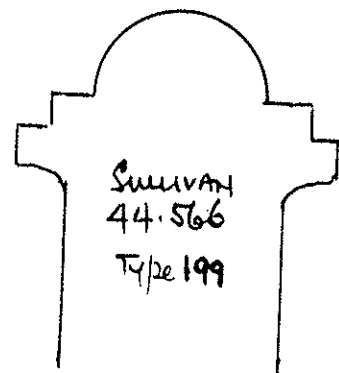
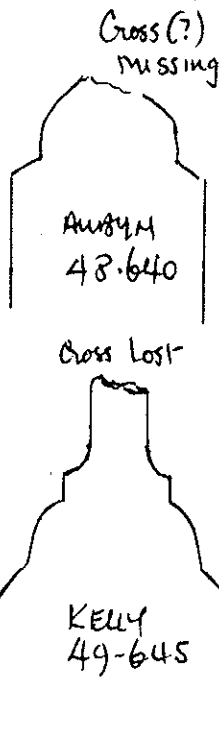
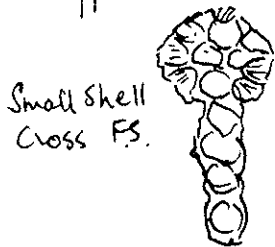
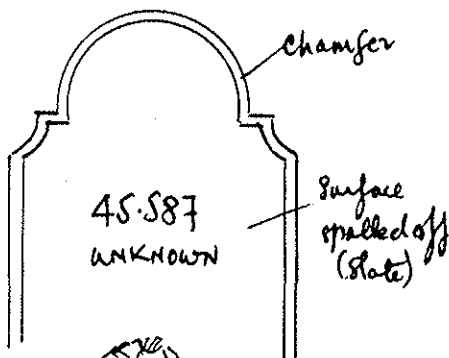
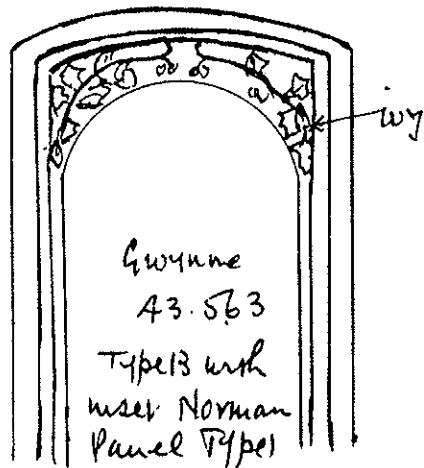
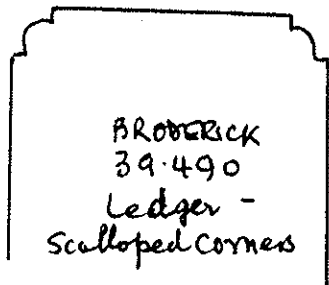
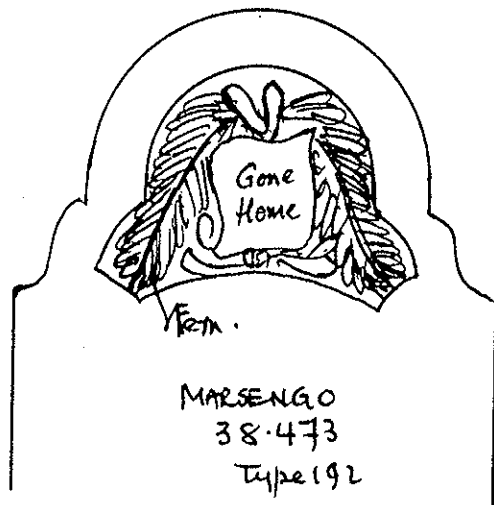
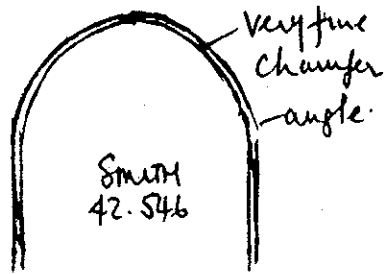
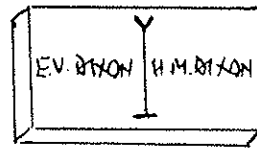
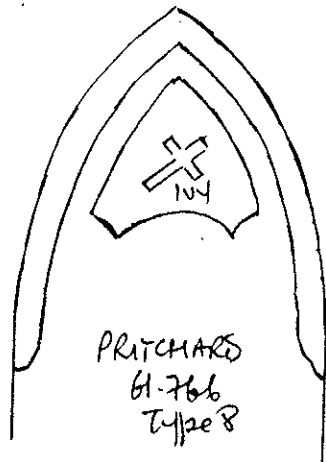
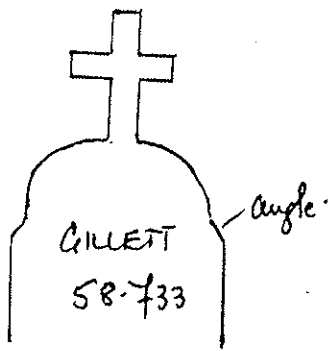
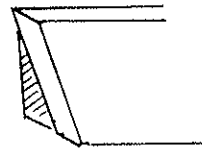

PLATE 69



61-767

White
Marble
Slab &
Block.



Top Broken

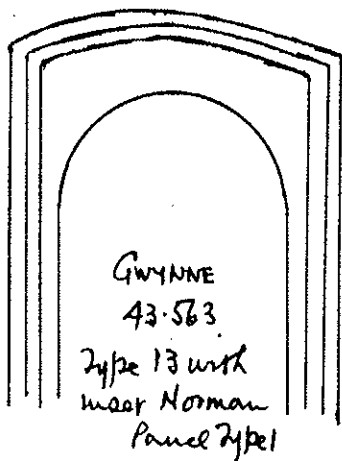
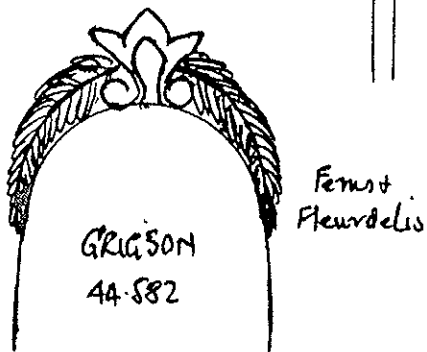
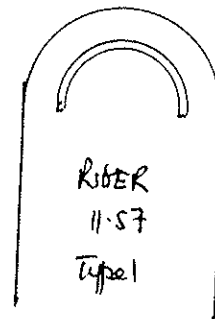
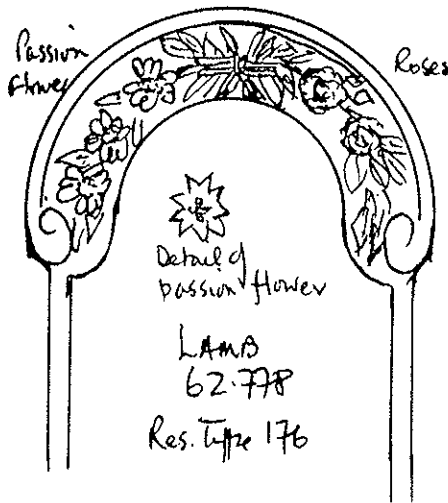
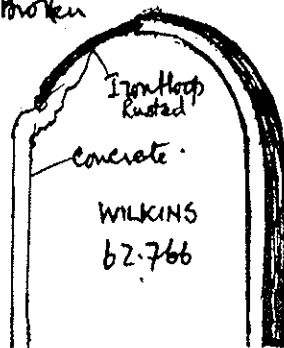
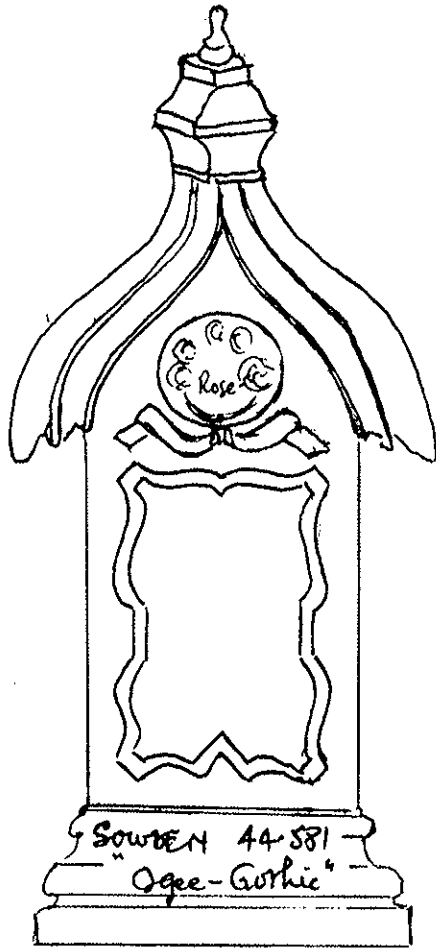
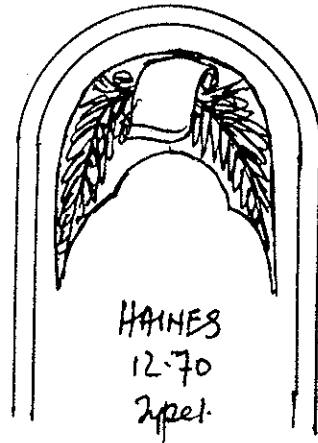

PLATE 70



SOWDEN 44-581
"Ogee-Gothic"



HAINES
12-70
Type 1

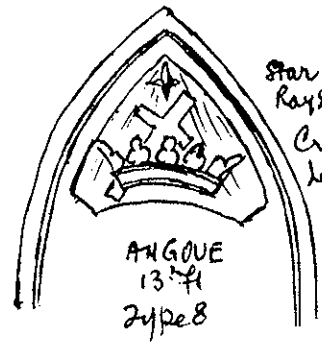

Star
Rays of light
Crown +
Latin Cross

ANGOVE
13-71
Type 8

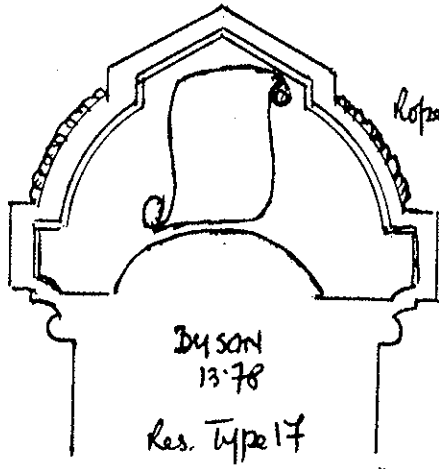

Kopfenwerk

DYSON
13-78
Res. Type 17
"leaked Norman"

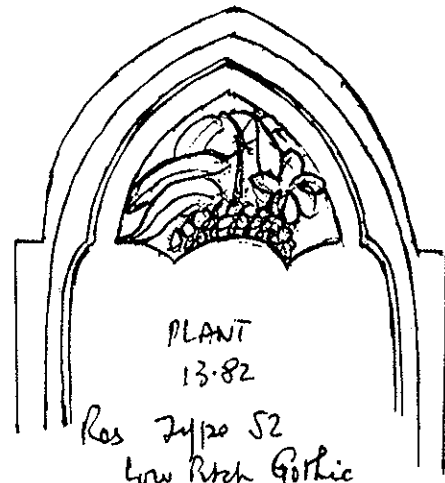

PLANT
13-82
Res Type 52
low Pitch Gothic

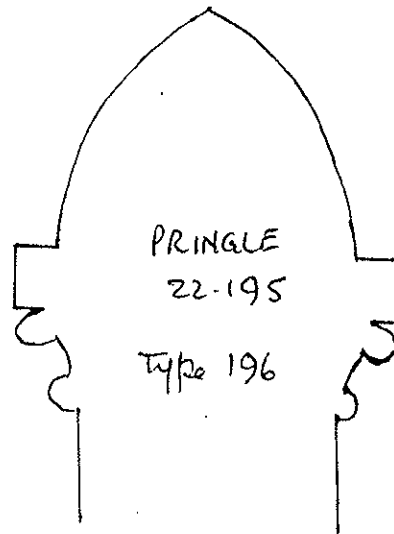
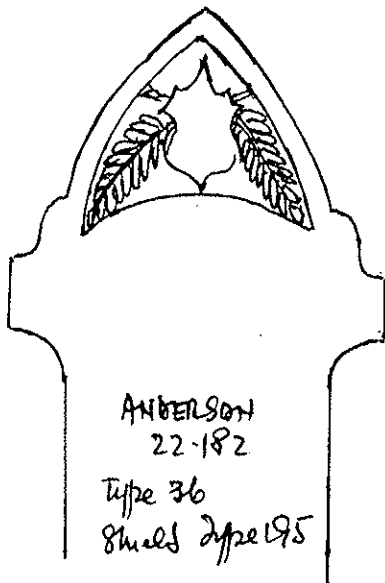
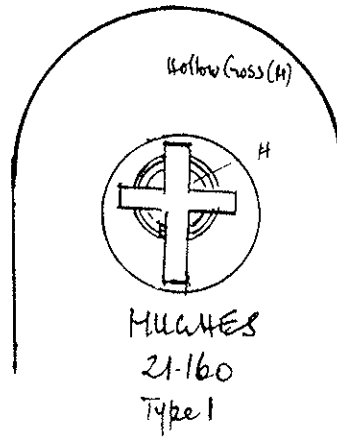
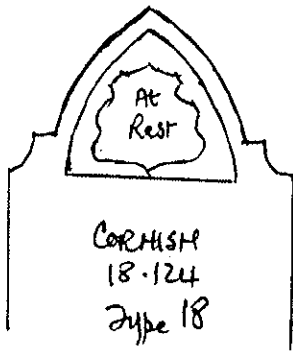
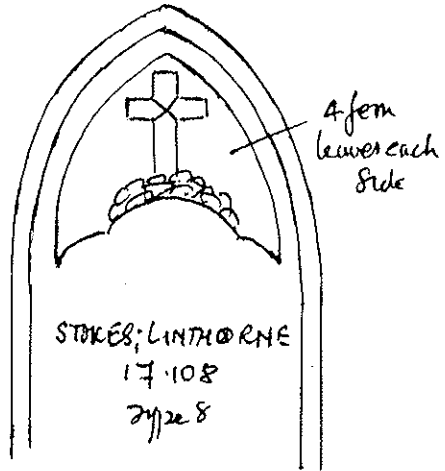
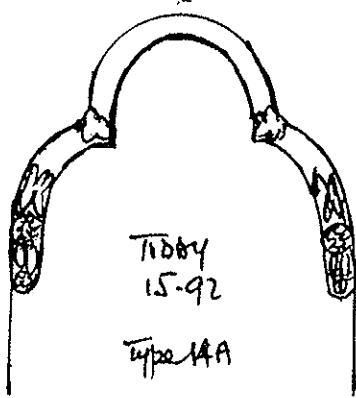
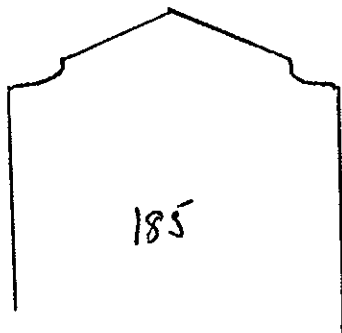
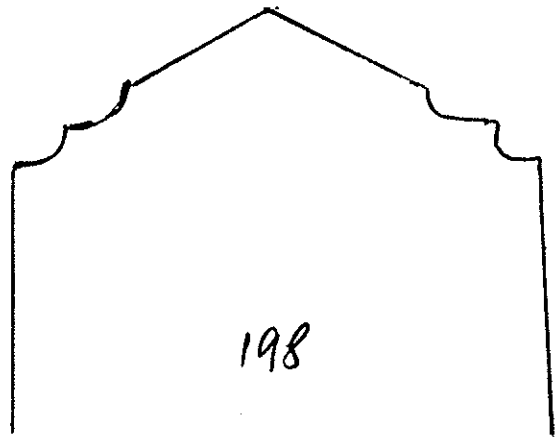
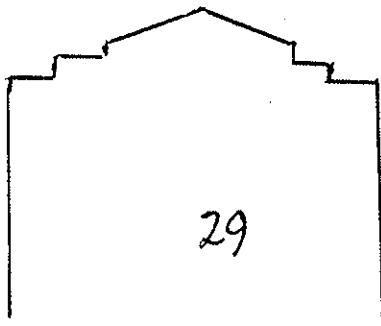
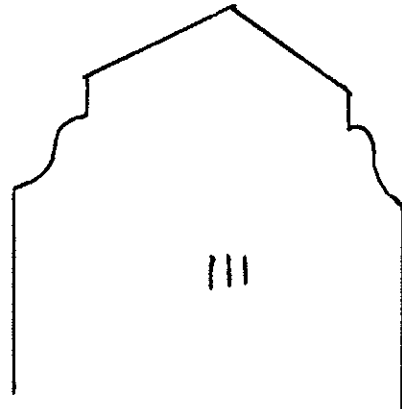
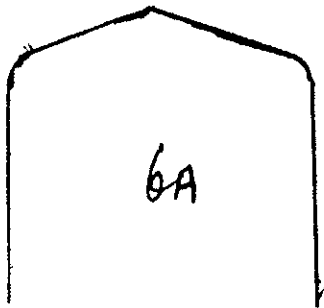
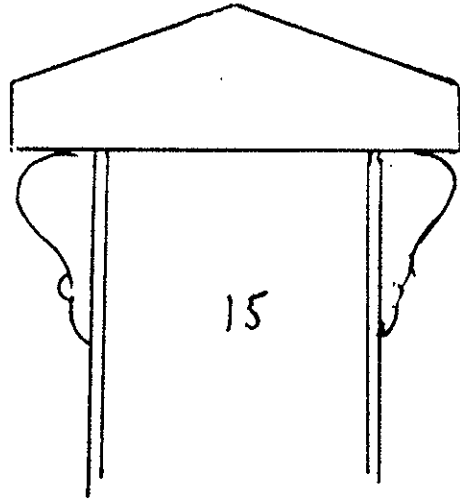
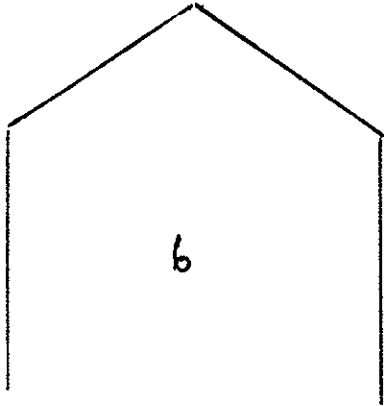
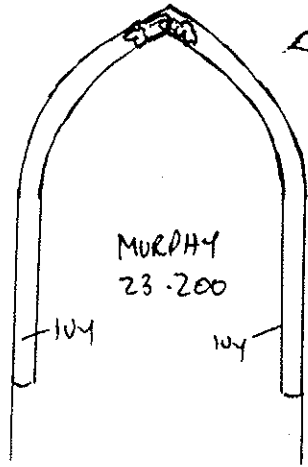

PLATE 72

PEAKED SLABS : POPULAR DESIGNS





Detail.
clasped
ivy stems

Chamfer

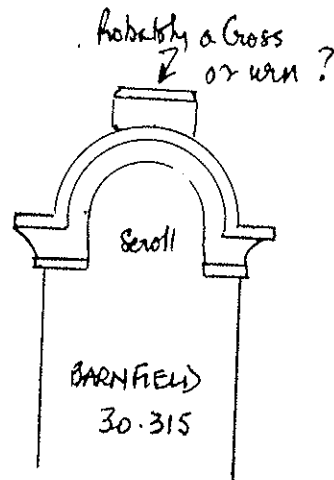
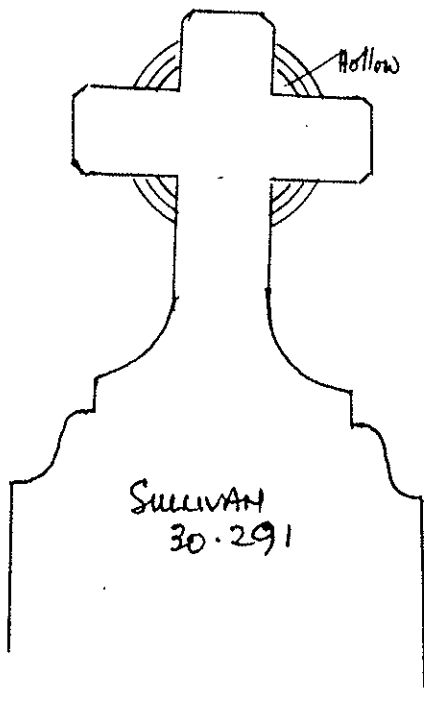
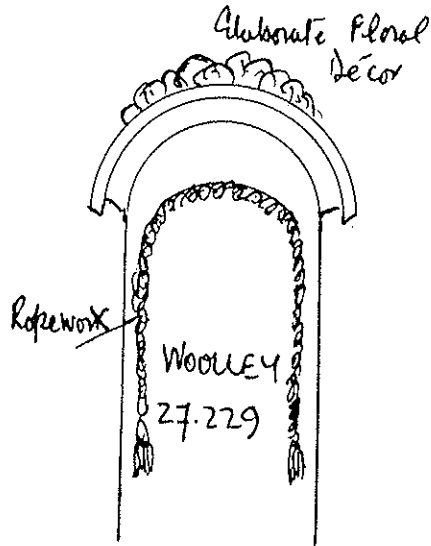
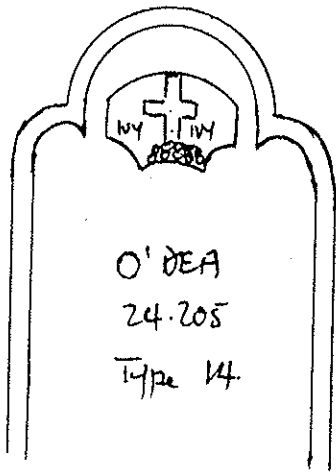
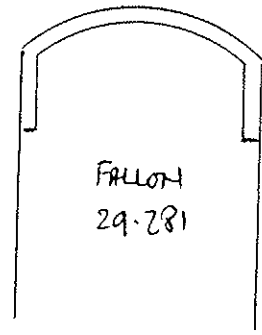
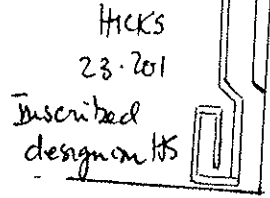
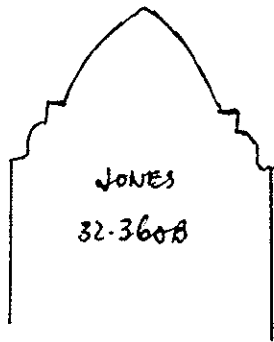
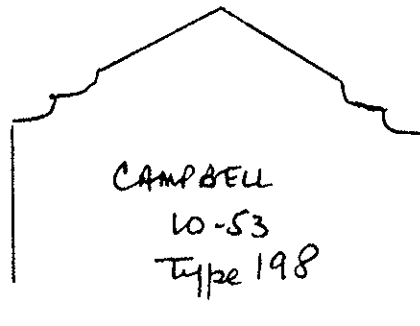
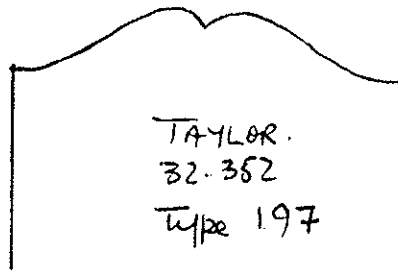
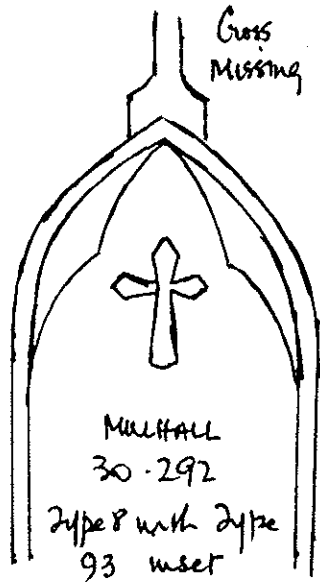
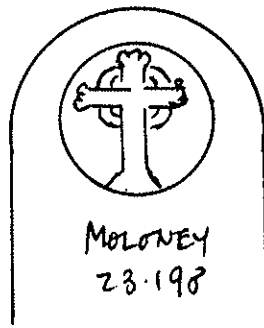
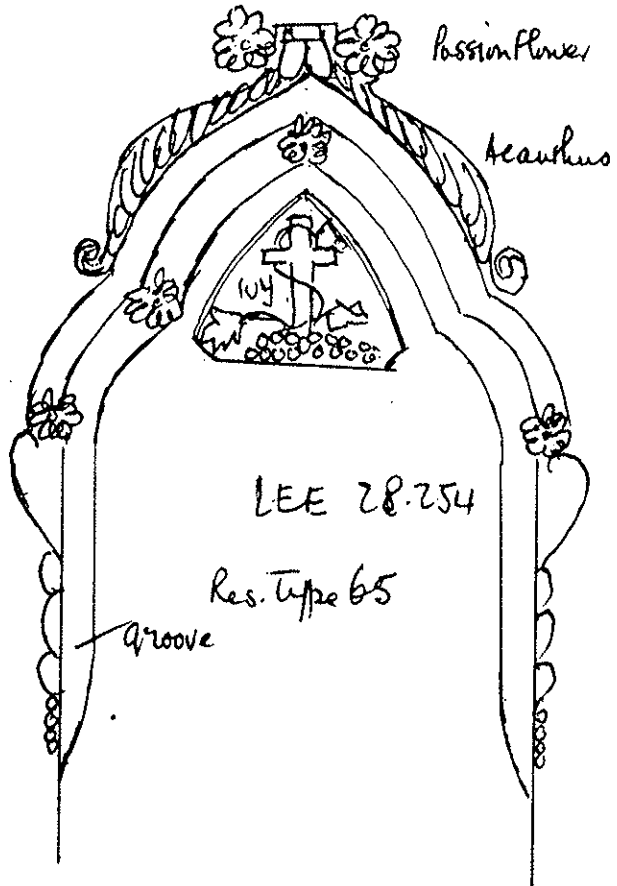

PLATE 74



(Wm?) Cross Missing



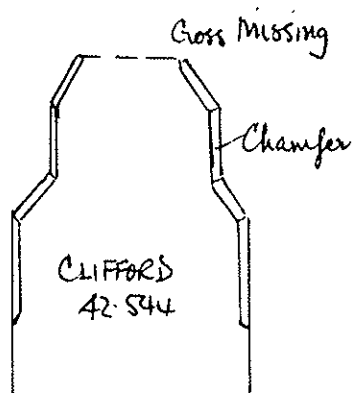
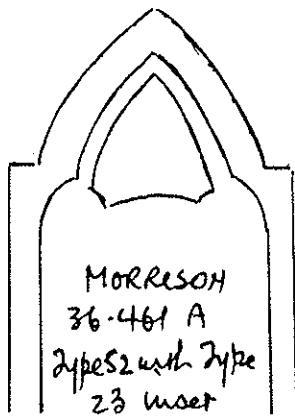
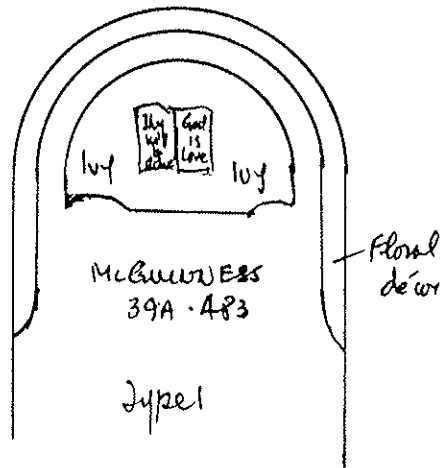
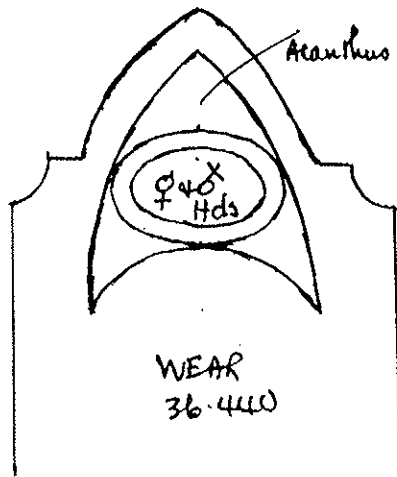
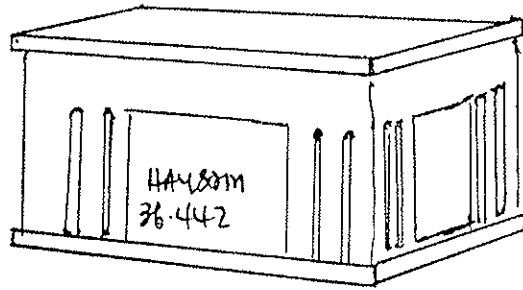

PLATE 76

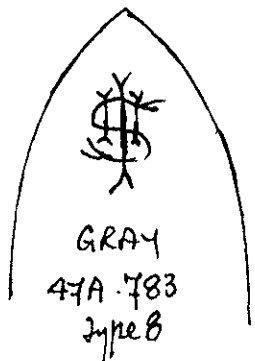
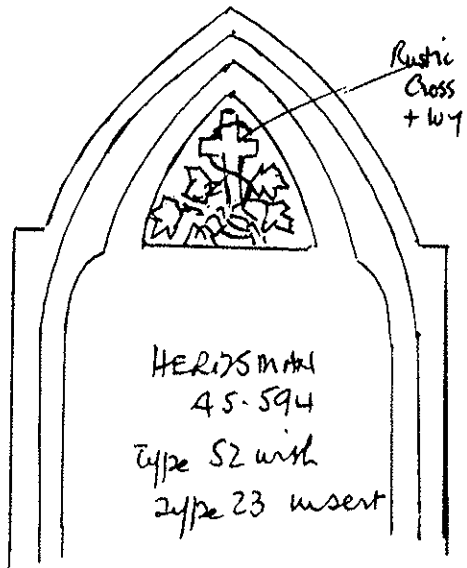
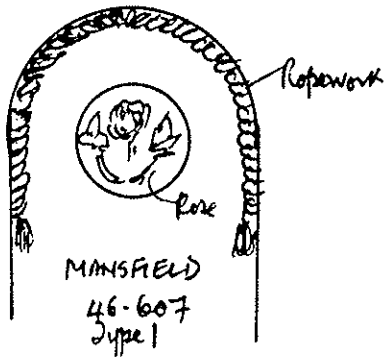
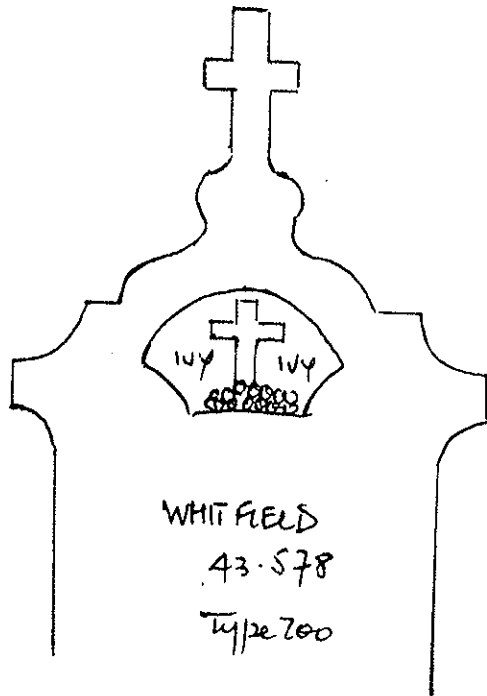
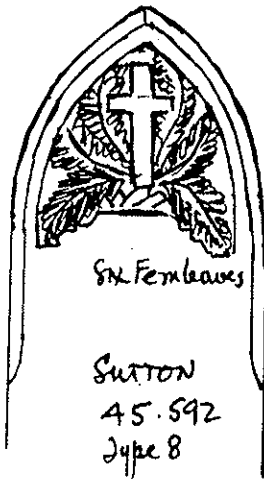
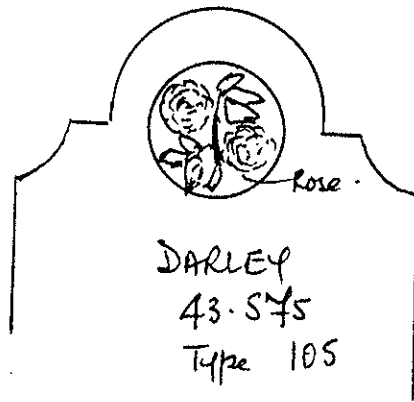

PLATE 77

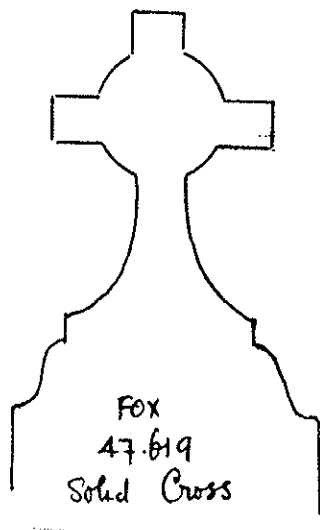
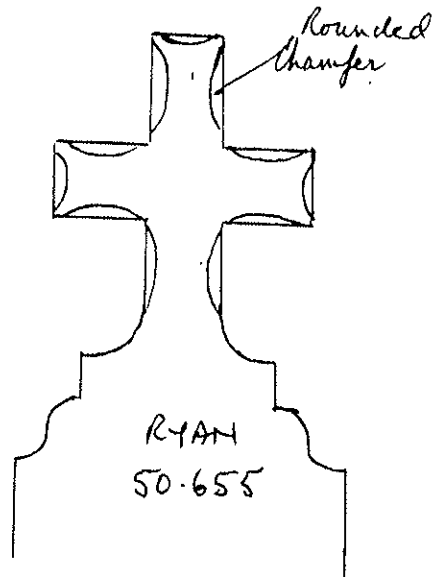
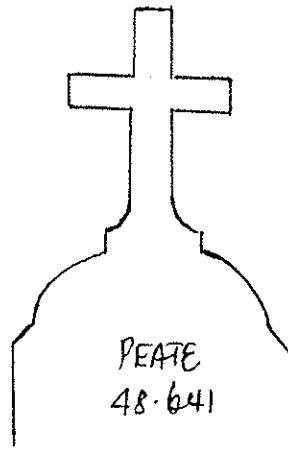
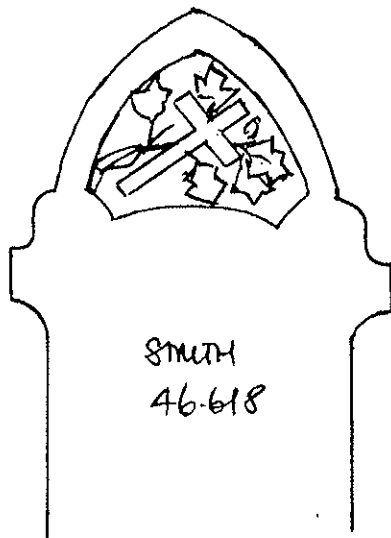
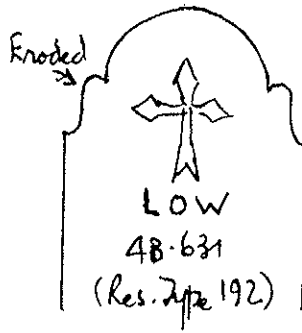
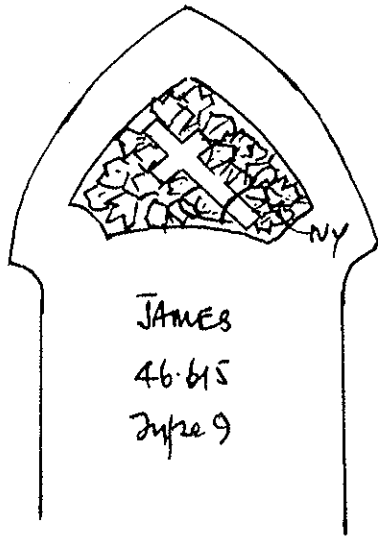
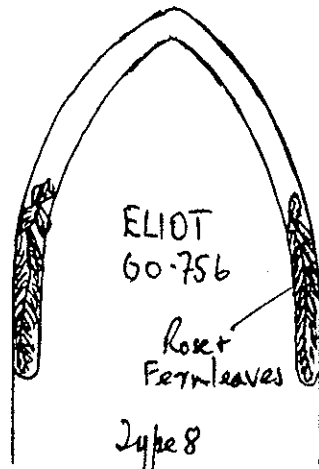
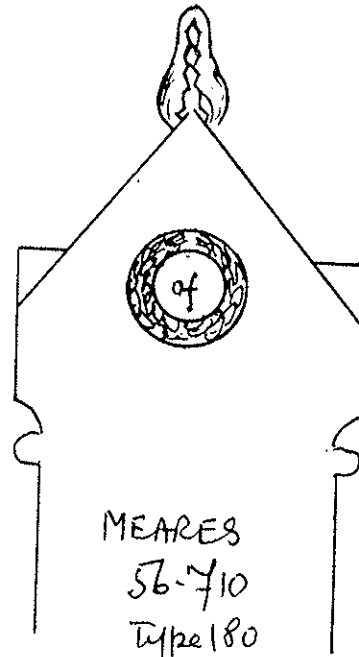
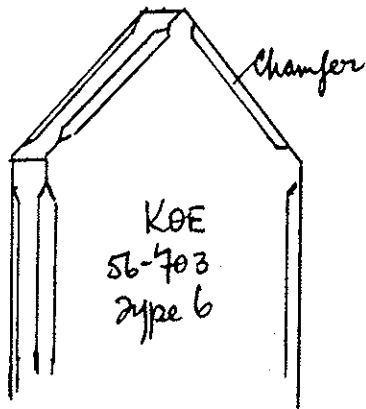
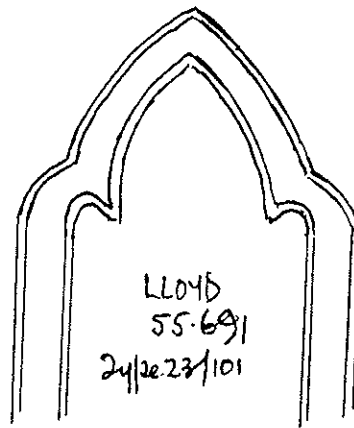
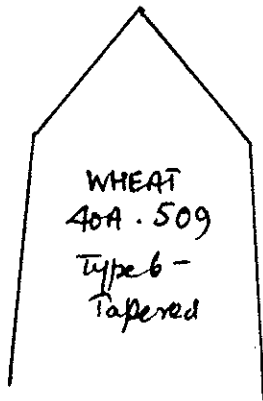
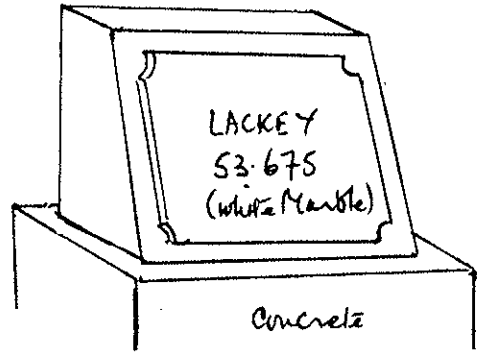
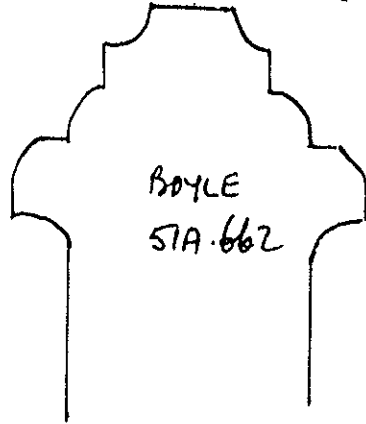

PLATE 78

Cross Missing



Only HS of this type
in EPL.

PLATE 79

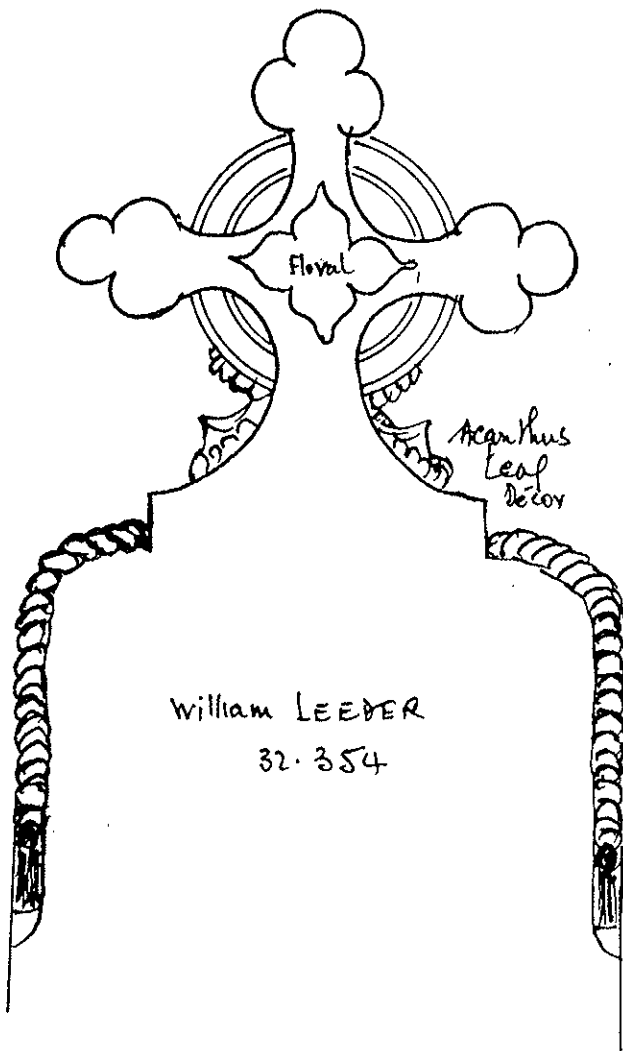
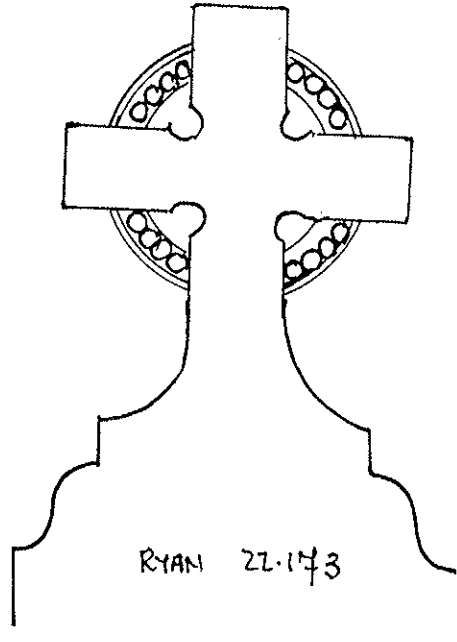
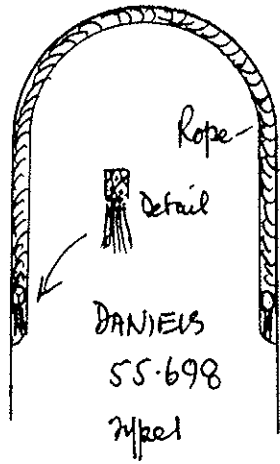

Ropework + Fassel

E W H N

A L O O

N. J. C.

NEELANDS 12-62

(Selection of Script used on Headstone)

Top Limestone Slab
badly eroded.

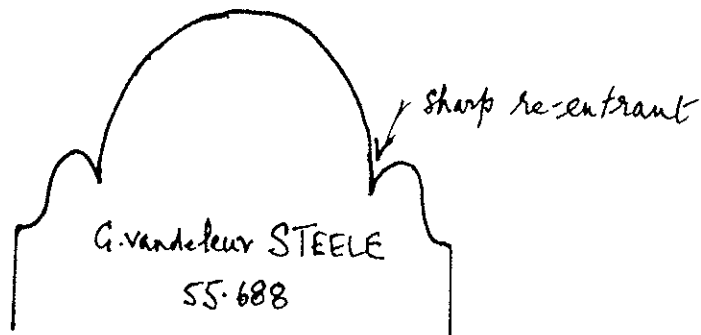
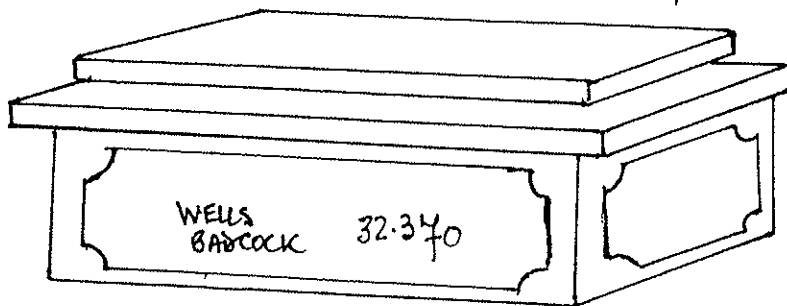

PLATE 81

1.



27-234 Emma Catchlove JAMES
Oval set in Gothic arch. Elaborate
ivy decor.

2.

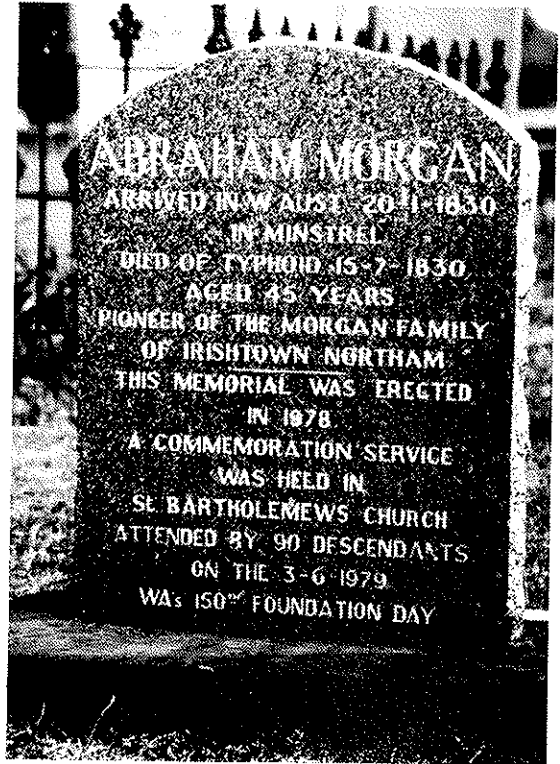

36-451 Abraham MORGAN
Simple Norman arch in granite.

3.

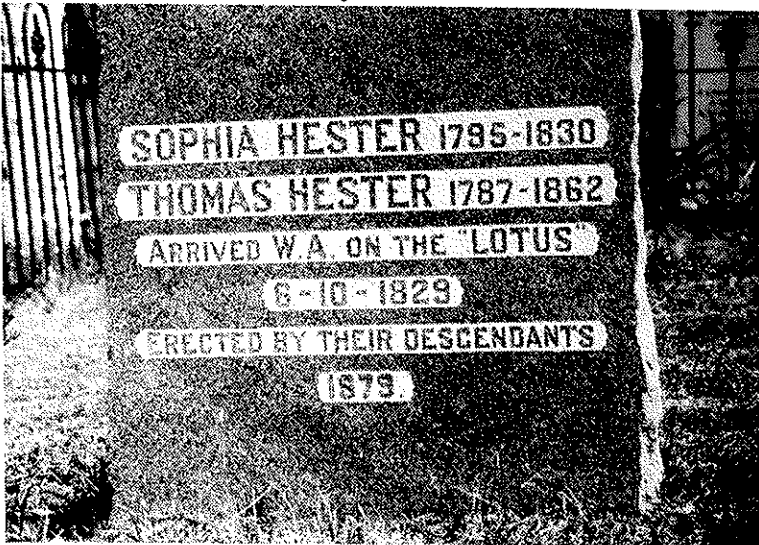

36-452 Sophia & Thomas HESTER
Grey granite block.

4.



36-457B Harriet E. MITCHELL
White marble pyramid with altar cloth
and draped urn.

5.



36-457A CHURCHYARD & MITCHELL
Marble Gothic slab with ornamental
capping over arch.

6.

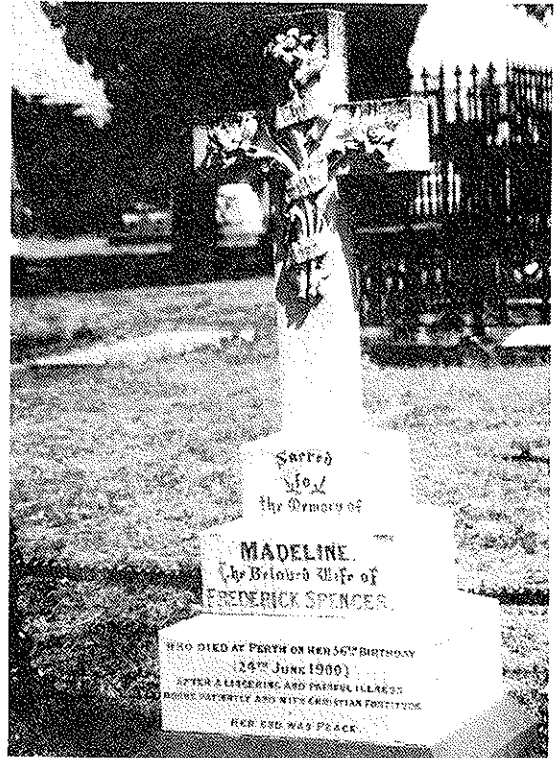

35-418 Madeline SPENCER et al.
Marble Calvary cross with floral spray
and sash.

7.



35-410 Robert Michael & Hannah MINSON
Shouldered Gothic slab with Latin cross,
wreath & sash surmounting insert Gothic
panel.

8.



35-407 Robert Napoleon & Alice BULLEN
Solid Celtic cross with pointed ends.
Masonic set square & dividers in
circular panel.

9.

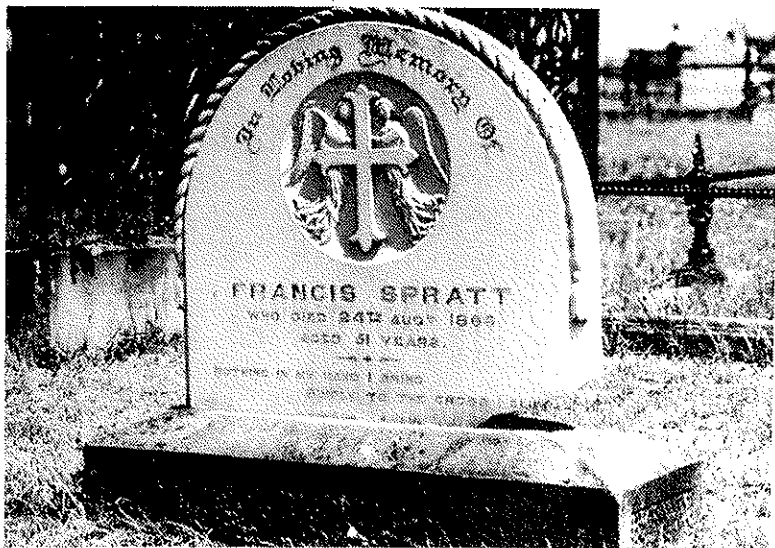

35-405 Francis SPRATT
 Marble Norman arch surmounted by
 tasselled rope. Cross with two angels
 within oval panel.

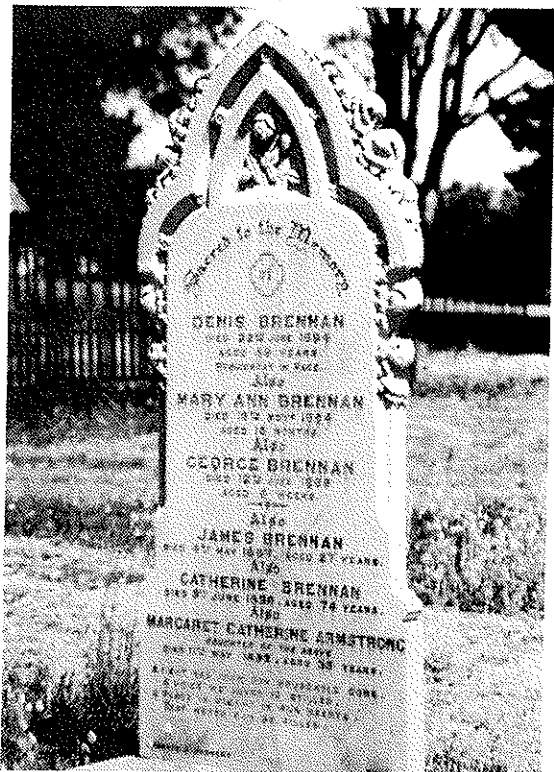

23-202 BRENNAN & ARMSTRONG
 Shouldered Gothic slab in white marble
 decorated with acanthus leaves. Rose
 in Gothic panel.

11.

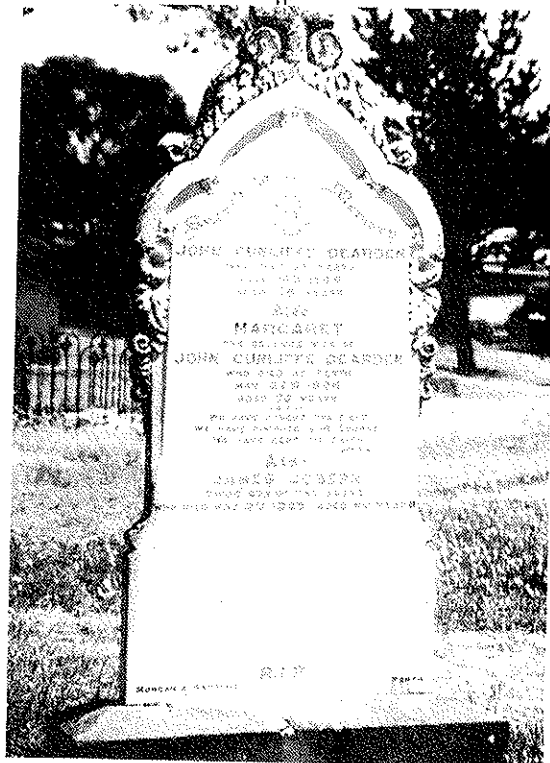

23-203 John Cunliffe, Margaret & Joseph DEARDEN
 Shouldered Gothic slab in white marble.
 Acanthus leaves surmounted by small rustic
 cross over arch.

13



21-167 A. & Martha HELMICH
Tiered marble block with altar cloth
and wreath, surmounted by draped urn.

14



22-195 Jessie PRINGLE
Marble Gothic slab, elaborate floral
decor; madonna lilies within Gothic
panel.

15



27-238 William Lyne MARTYN
Marble quadrangle cross on fluted slab.



28-267 Edward & Anne Louise HAMERSLEY
Shouldered Norman slab. Panel with
shield surmounted by winged lion, latin
cross and closed visor.

17.



30-295B James CARMICHAEL
Marble Calvary cross with anchor and chain.

18.



27-220 Margaret M. DICKSON
Shouldered Gothic slab; floral decor on shoulders. Scroll & floral decor within Gothic panel.

19.

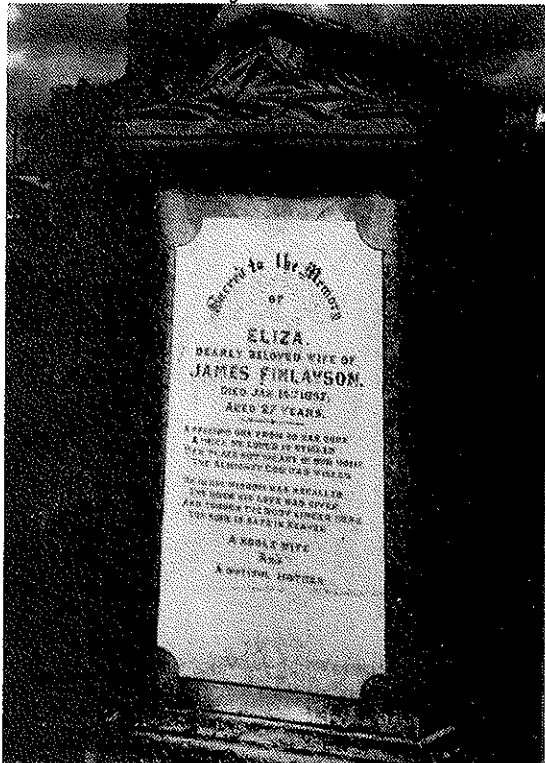

27-222 Eliza FINLAYSON
Gabled slab in concrete with floral decor. White marble slab on east face.

20.



27-213 Patrick & Jane CLAFFEY et al.
Norman arch in sandstone; base eroded.
27-214 Catherine & Frances CLAFFEY
Rustic latin cross in white marble surmounting rough hewn granite block.

A0

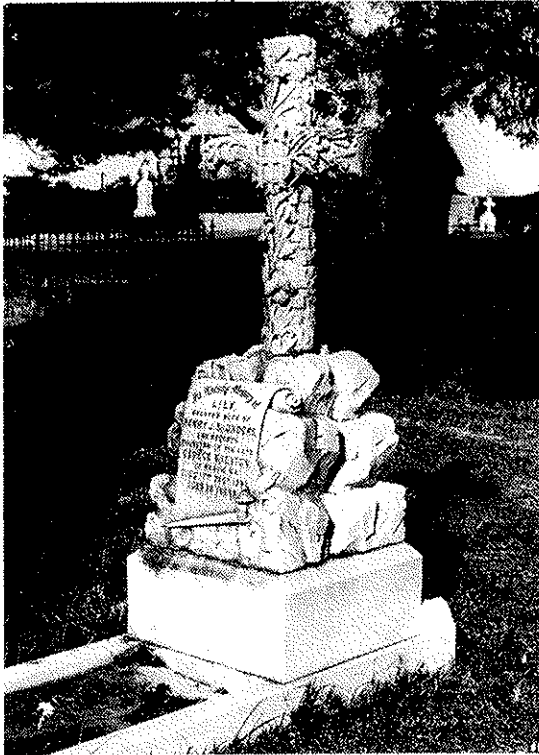

28-258 Lily SAUNDERS
Rustic cross with floral decor & I.H.S.
on rough hewn block with scroll & basal
block, all in white marble.

A1

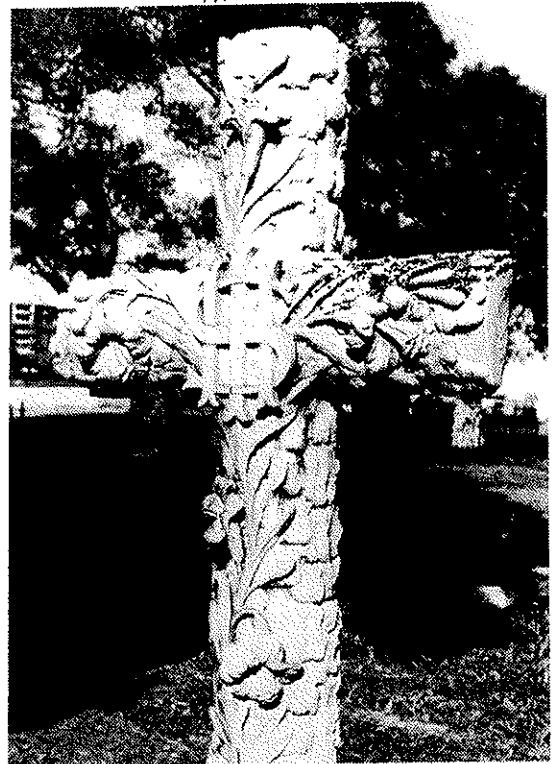

28-258 Lily SAUNDERS
Details of rustic cross with madonna
lilies and I.H.S.

A2



20-148 David, William & Mary REGAN
Norman slab with tasselled plaited rope.
Panel with two angels clinging to cross.

A3

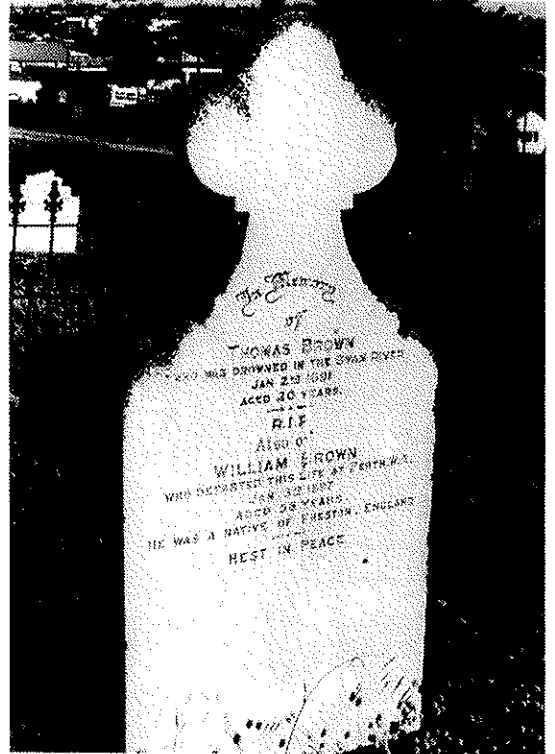

21-163 Thomas & William BROWN
White marble slab carved to represent
shamrock leaf.

A4



21-161 Denis NAUGHTON
White marble cross on slab. I.H.S.
with elaborate shamrock decor.

A5



20-150 Netta & Maria SMITH et al.
Rustic cross with dove on massive blocks
with scroll.

A6

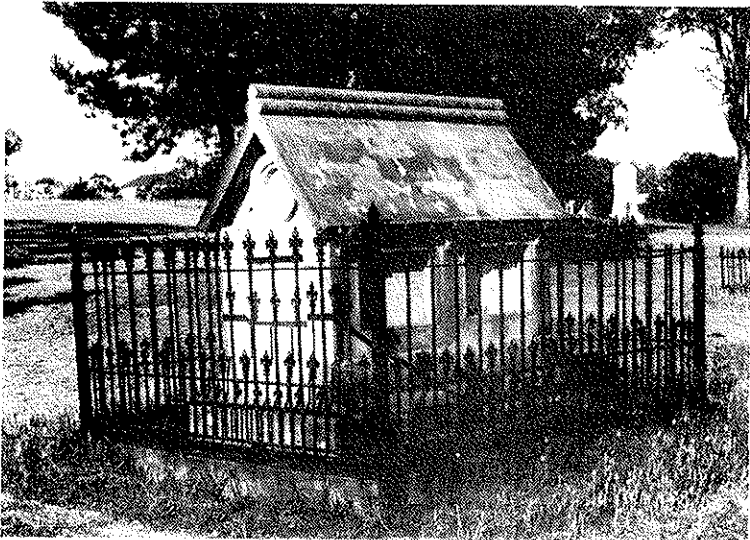

21-165 FARRELLY & NUNAN
Peaked chest in concrete with marble
plaques.

A7

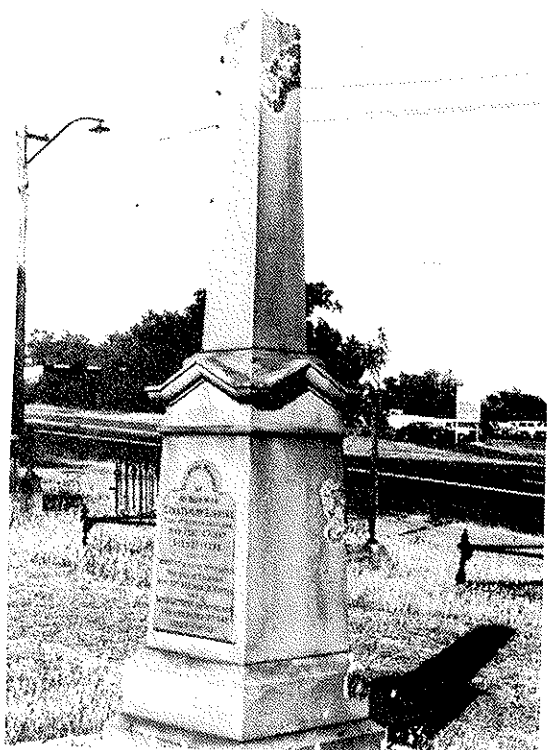

3-11 Gina Taylor, Dorothy & David
Littster BUNNING
Obelisk in granite on concrete base.

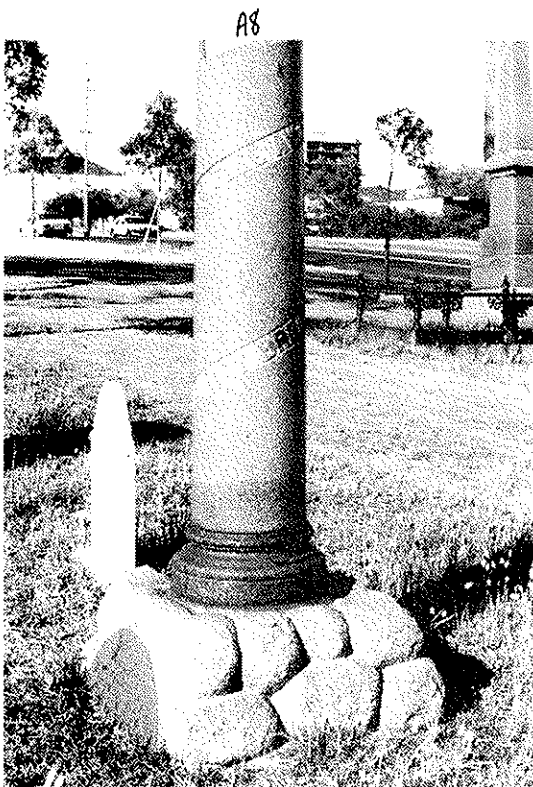

4-18 Vincent Edward NESBIT
Broken obelisk in syanite on rock base.
Rising spiral inscription: "Till the day
breaks & shadows flee away". A10

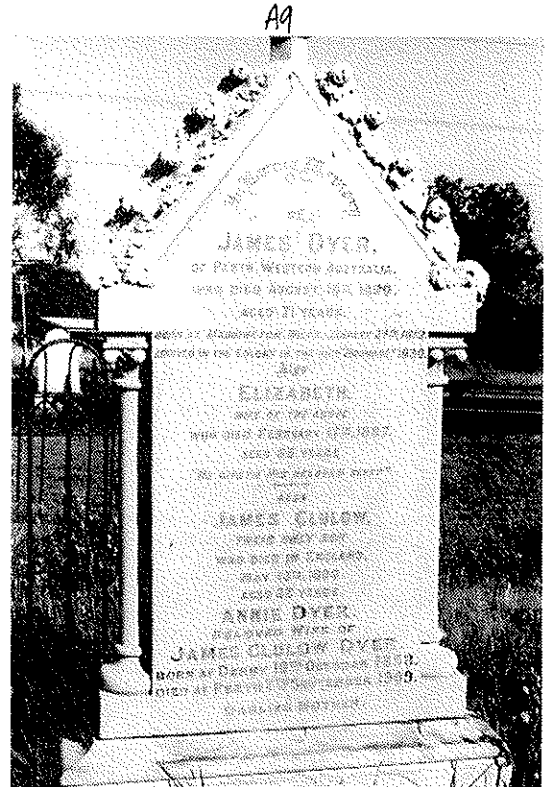

5-24 CLULOW & DYER
Peaked slab with acanthus leaf decor
and columns.



5-26 Phoebe HYMUS & Anne BIRCH
Gothic slab with floral panel & sash.



6-31B Somers & Laura BIRCH
Marble Norman slab with scroll & two
fern leaves.

A12

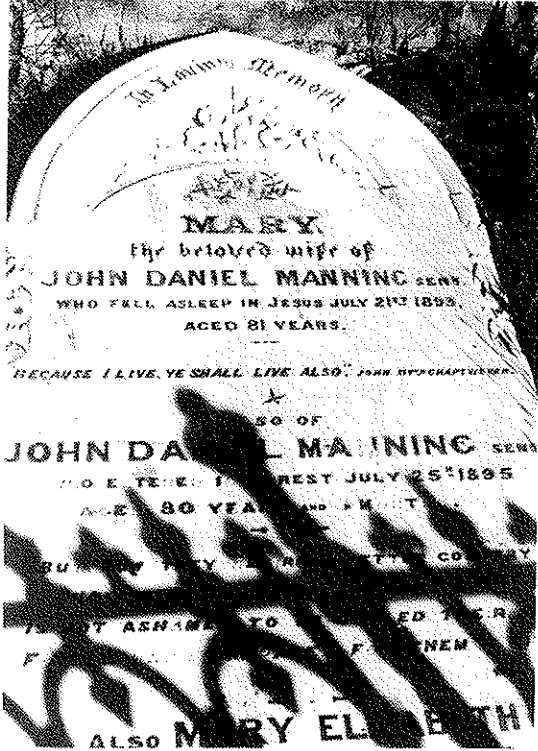

8-40 Mary, John Daniel & Mary Elizabeth MANNING
Acute Gothic arch and floral decor in Gothic panel.

A13

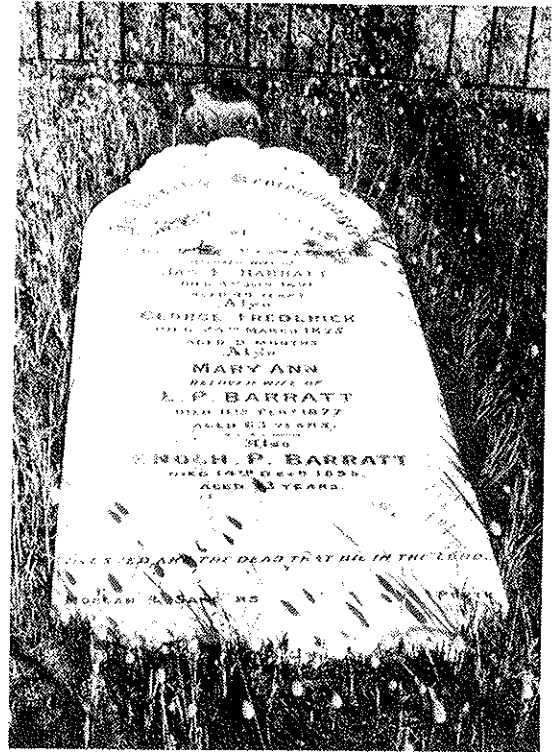

12-63 Frances Elizabeth, James E. BARRATT et al.
Norman slab with acanthus leaves over arch.

A14



12-67A Caroline STONEMAN
Open Celtic cross on slab.
12-67B T. FARMER, F.A. BAILEY et al.
Shouldered Norman slab. Floral panel with sickle.
12-67C J.E. & W. INKPEN et al.
Peaked slab of Portland limestone.
Lower part badly eroded & illegible.

A15



13-71 Thomas & Mary ANGOVE;
Annie Maria BROWN
Gothic panel with crown & latin cross bathed in heavenly rays.

A16

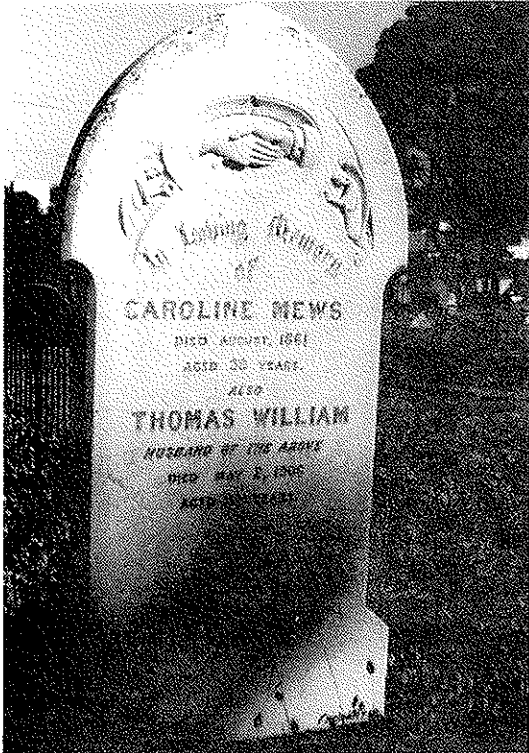

13-79 Caroline & Thomas W. MEWS
Gothic slab: panels with clasped male & female hands; two angels with wreaths.

A17



13-81 CASS; BIGNELL & KRUGER
Shouldered Gothic slab. Gothic panel with angel clinging to Latin cross; ivy decor.

A18



13-83A John Walter & Mary Ann McCANN
Shouldered Gothic slab. Gothic panel with hand carrying broken chain, pointing down from heaven.

A19

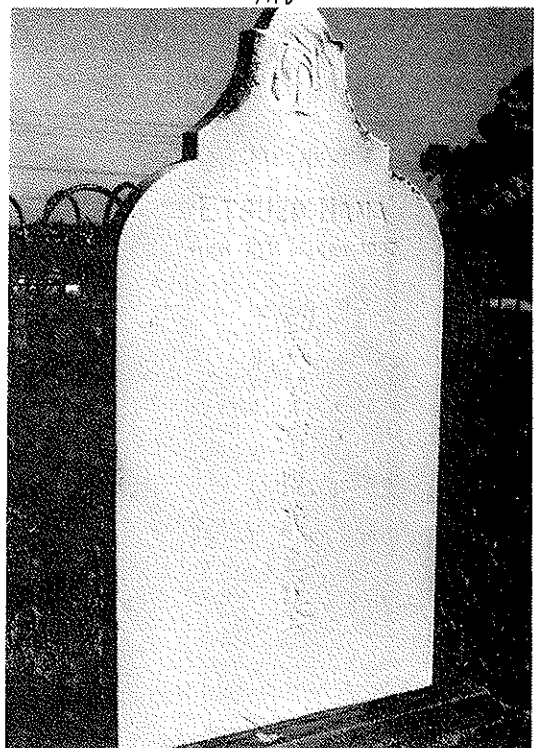

13-85 Etsuzo HAMA
Ogee-gothic slab. Thistle decor; Japanese (Presbyterian).

A20



12-70 Ewan Paul Arbuthnot HAINES
Norman slab with scroll and two fern
leaves.

A23



15-98 OSBORNE family grave
Norman slab with tasseled rope over
arch; rose garland & sash.

A21



19-142 MONGER family vault
Pedestal surmounted by angle with garland dropping
flowers on grave; scroll with rose garland and
urn.

A22



A24



15-99 Edward & George WELLS
Shouldered Norman slab; panel with
rose and madonna lily.

A25



15-101 Herbert GLOVER
Iron plaque with child holding flower
over grecian urn.

A26

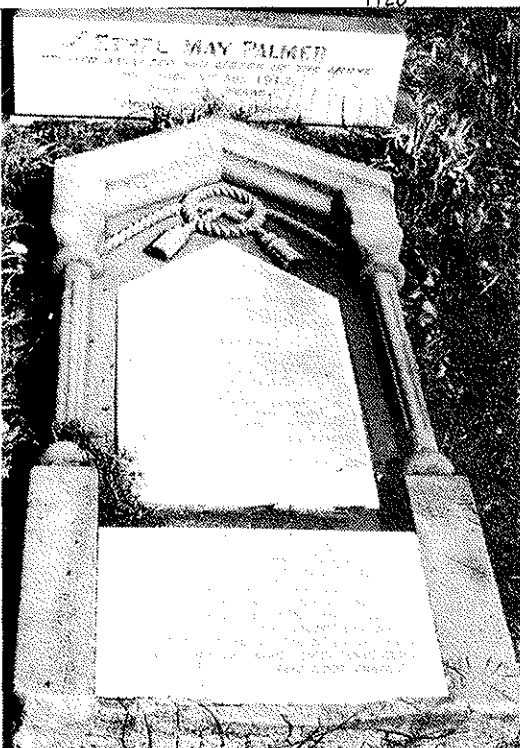

16-106 PALMER family
Peaked slab with columns; tasselled
rope.

A27

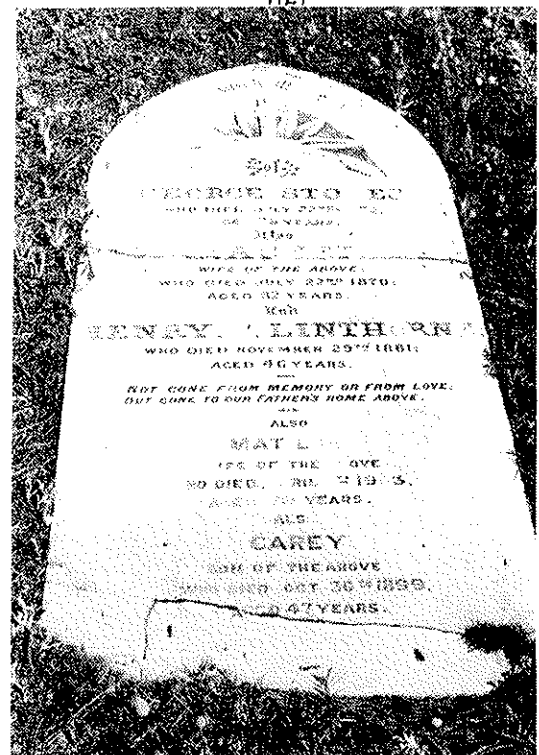

17-108 STOKES & LINTHORNE
Gothic slab with latin cross and fern
leaves in Gothic panel.



18-119 Abraham KOTT
Pedestal with altar cloth & draped urn.
Jewish.



17-110 Evelyn STEVENS
Gothic slab; Gothic panel with latin
cross and ivy.

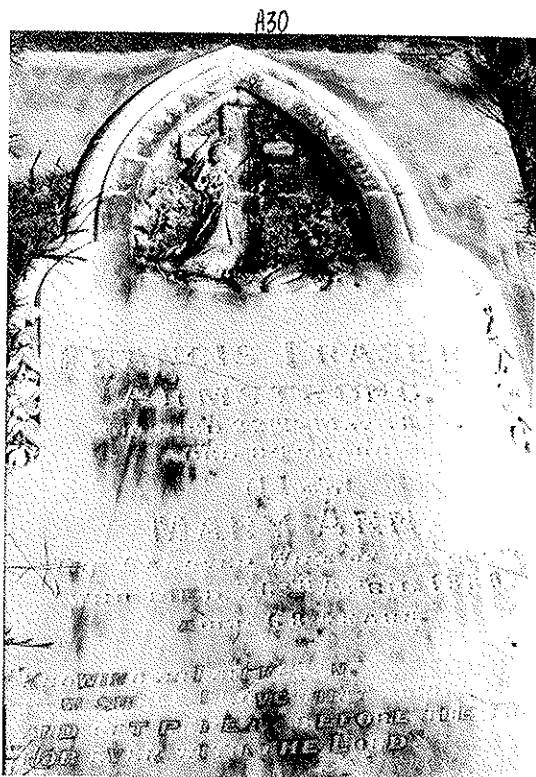

17-112 Francis Fraser & Mary Ann
ARMSTRONG
Shouldered Gothic slab. Gothic panel
with angel clinging to cross.

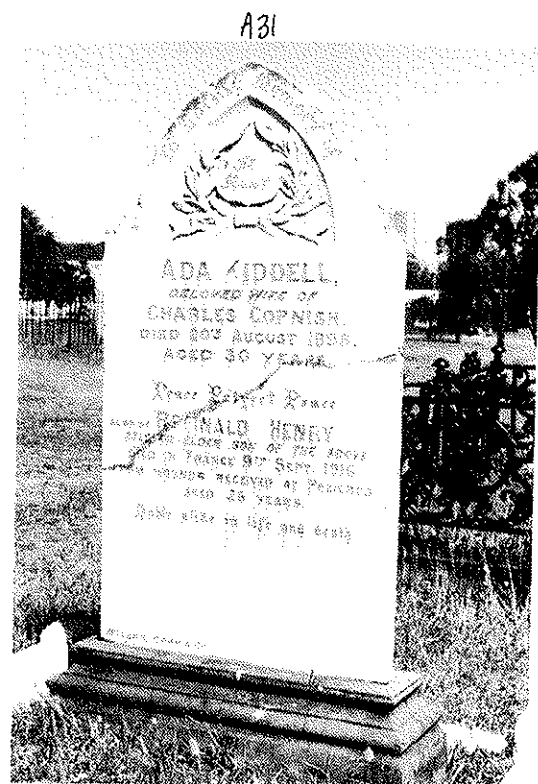

18-124 Ada Kiddell & Reginald Henry
CORNISH
Gothic slab. Shield with leaf decor and
sash in panel.

A32

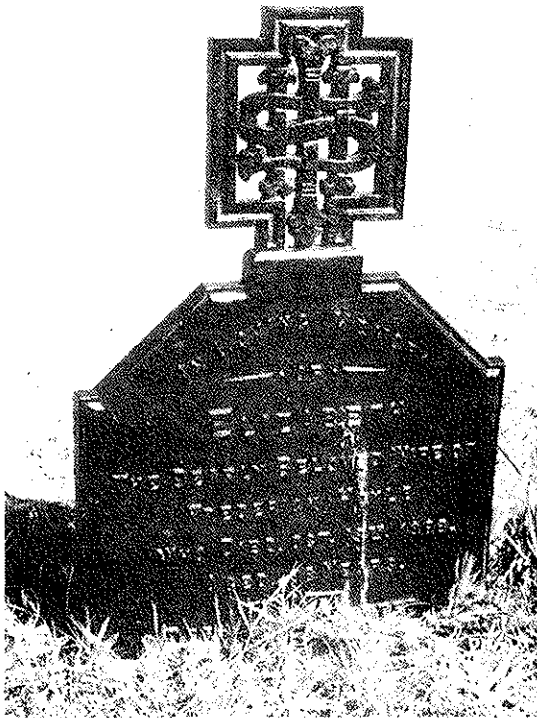

19-143 Elizabeth HOYLE
Iron plaque with elaborate I.H.S. design.

A33



19-139 Hannah & Daniel WANSBROUGH
Shouldered Norman slab in marble on granite base.

A34



20-153 John J. & Leslie John ELSEGOOD
Pedestal monument surmounted by draped urn.

A35

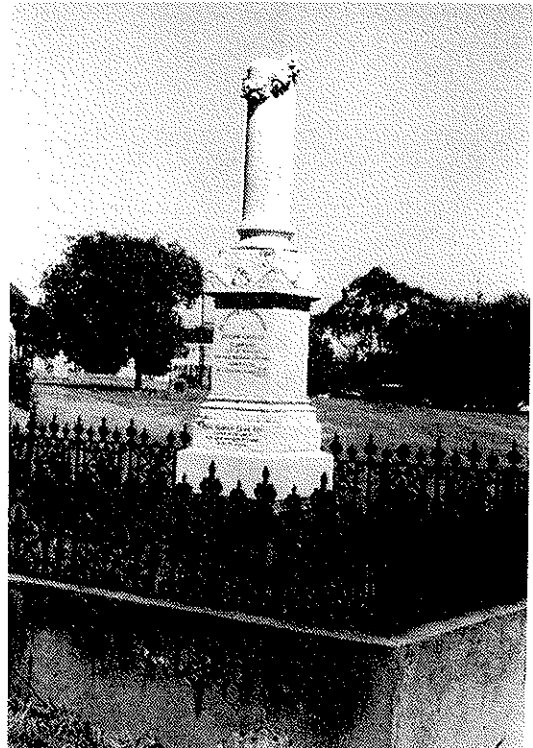

20-151 Joseph Charles CLARKSON and Hannah Eliza KEY
Five tiered pedestal surmounted by broken obelisk with wreath.

A36



22-175A Teresa QUINLAN

22-175B Daniel CONNOR

Two beautiful Celtic crosses surmounted by Lych gate.
Celtic harp on 22-175A.

A37

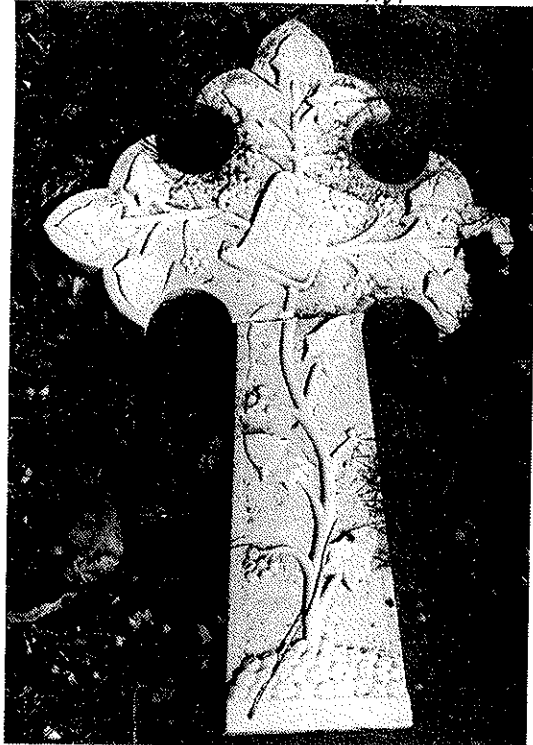

22-174 Katie MURPHY

Shamrock cross with scroll (I.H.S.) and ivy.

800



46-613 Sir Thomas COCKBURN-CAMPBELL Bart.
Castellated pedestal surmounted by
shrouded urn; rose panel on east face.

81



44-577 FFARRINGTON family grave
Shouldered Gothic slab; madonna lilies
in panel.

82

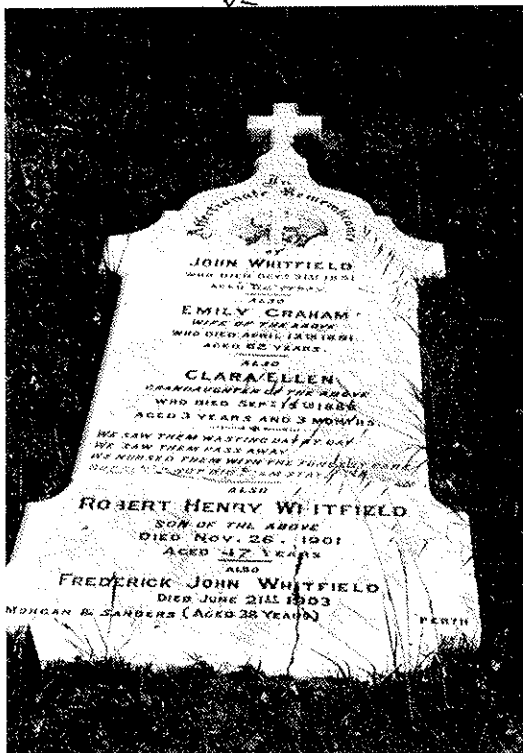

44-578 WHITFIELD family grave
Flanged Gothic slab surmounted by small
latin cross. Panel with latin cross
entwined by ivy.

83

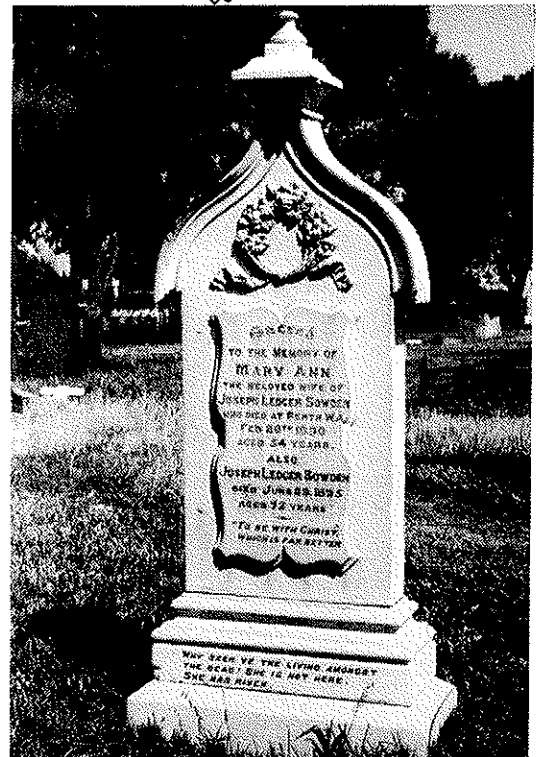

44-581 Mary Ann & Joseph Ledger SOWDEN
Ogee-gothic slab with wreath & sash.
Formerly surmounted by grecian urn.

84

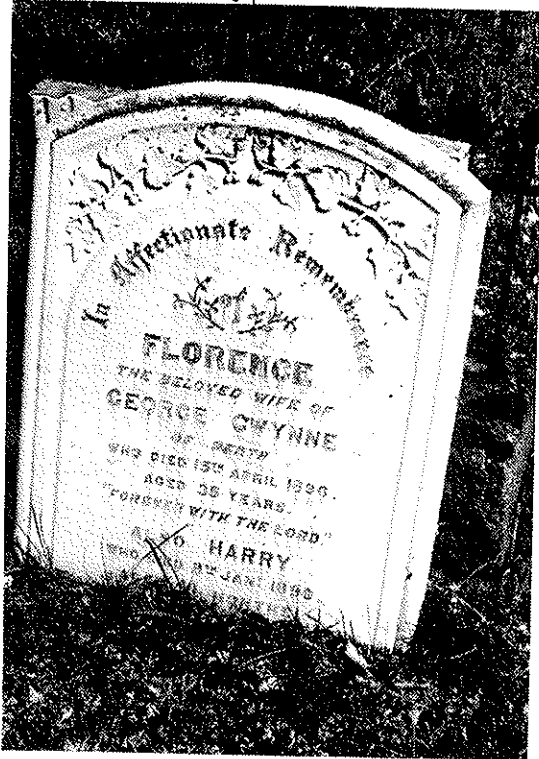

43-563 Florence, Harry & Bertie GWYNNE
Rounded oblong slab; ivy decor.

86

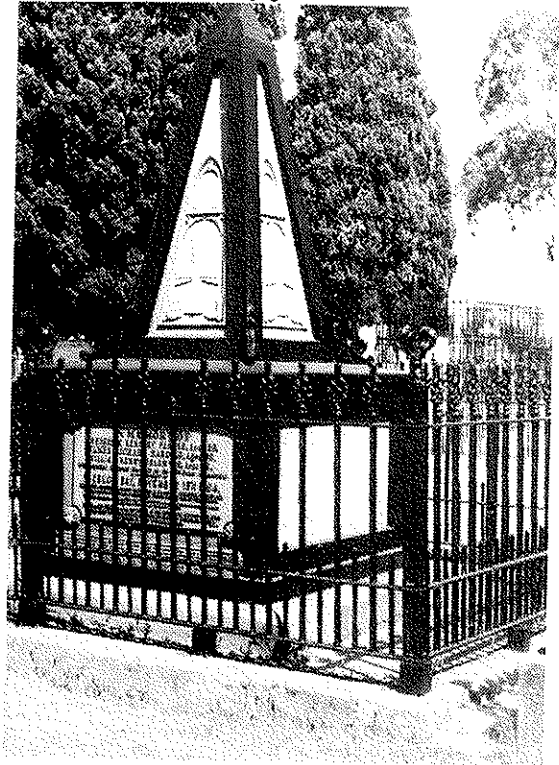

36-445 PANTER, HARDING, GOLDWYER,
Maitland BROWN
Metal pyramid with cross on all four
sides, on masonry base. Monument
erected by W.A. Government.

87

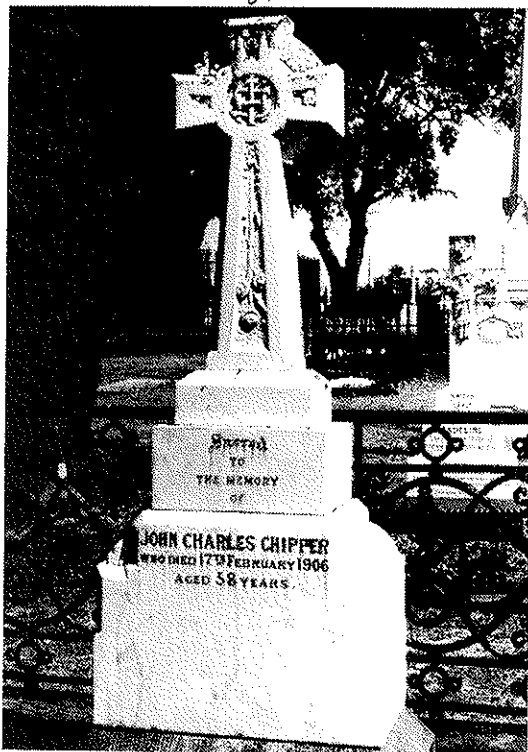

36-446A John Charles CHIPPER
Celtic cross with I.H.S. and rose
decor.

88



36-447 John CHIPPER et al.
Chest; slate top.
36-448 Stephan James CHIPPER et al.
Gabled monument surmounted by urn
with wreath.
36-449 Stephan James CHIPPER & children
Chest; slate top.

89

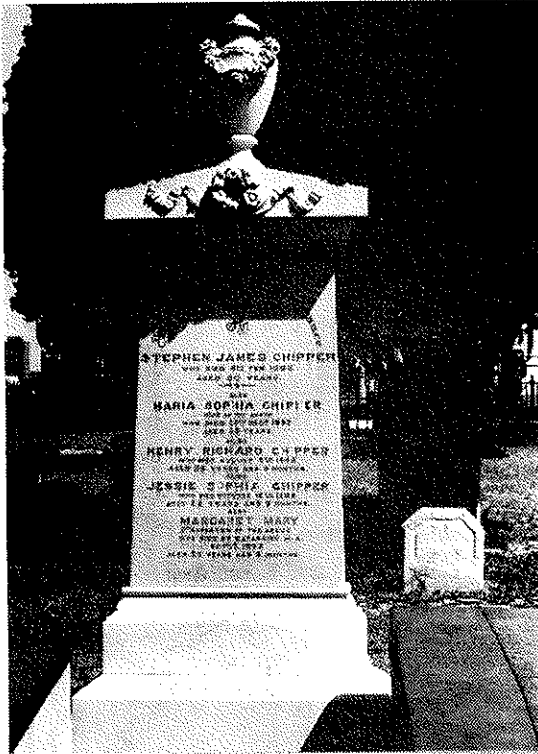

36-448 Stephan James & Maria Sophia
CHIPPER et al.
Gabled monument surmounted by urn &
wreath. Garland & sash on peak block.

810

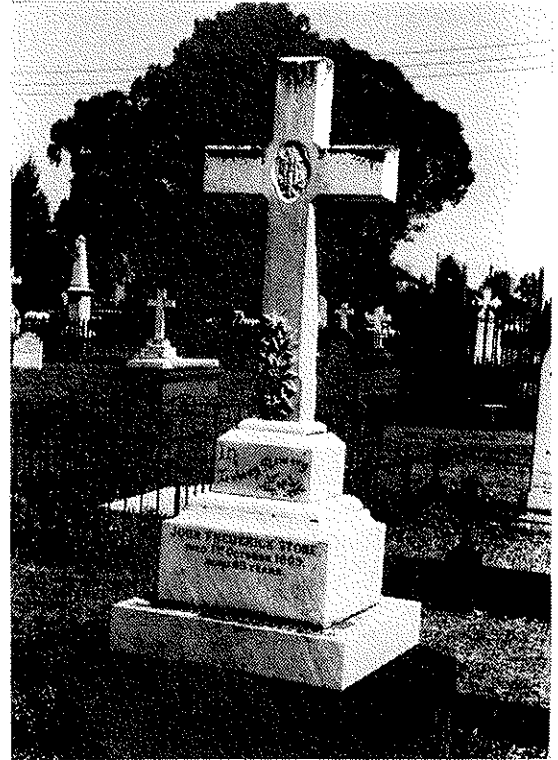

36-454A John Frederick & Frederick
Norman Alfred STONE
Calvary cross with I.H.S. panel and
passion flower decor.

811



36-457A CHURCHYARD & MITCHELL
Gothic slab with ornamental cap over peak.
36-457B Harriett E. MITCHELL
Pedestal with altar cloth surmounted by
draped urn.

812

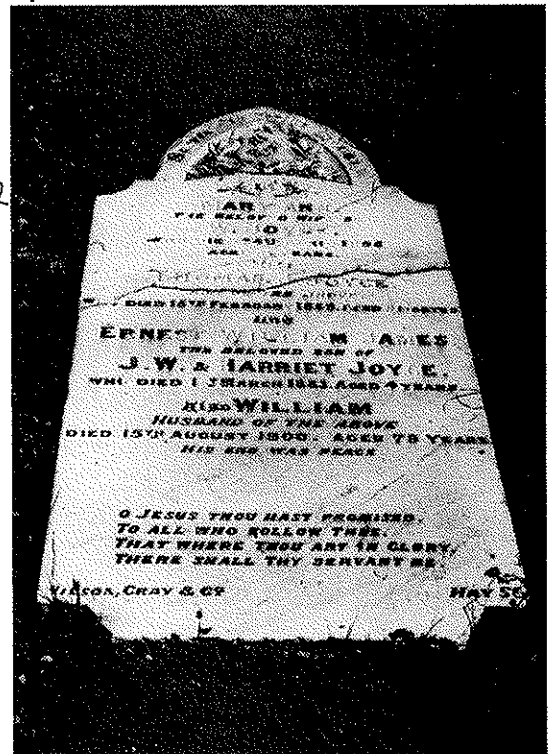

35-425 Mary Ann & William JOYCE et al.
Gothic slab; panel with shield, floral
decor and sash.

B13



35-412 SNOOK & WIGGLESWORTH
Pedestal with wreath, surmounted by
angel with armful of blossoms distributing
flowers below.

B14

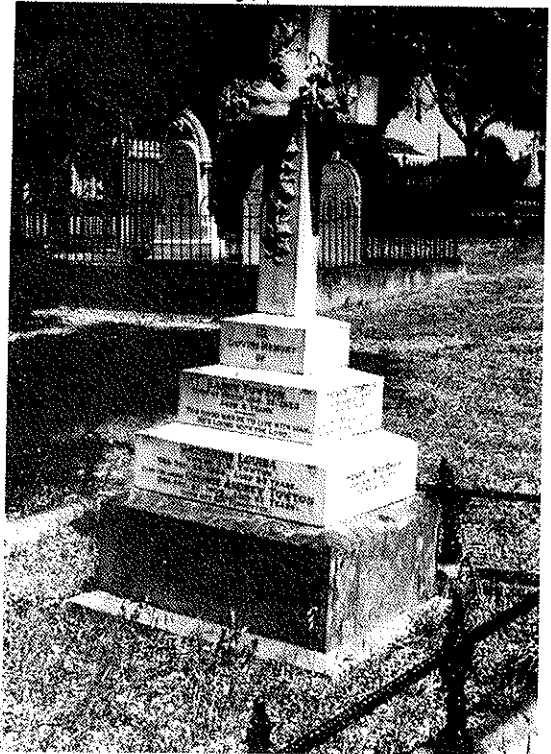

35-411 Harry TOWTON et al.
Calvary cross with dove and ivy decor.

B15



35-409 William & Margaret Madole HALL
plus children
Gothic slab with rose decor in panel.

B16

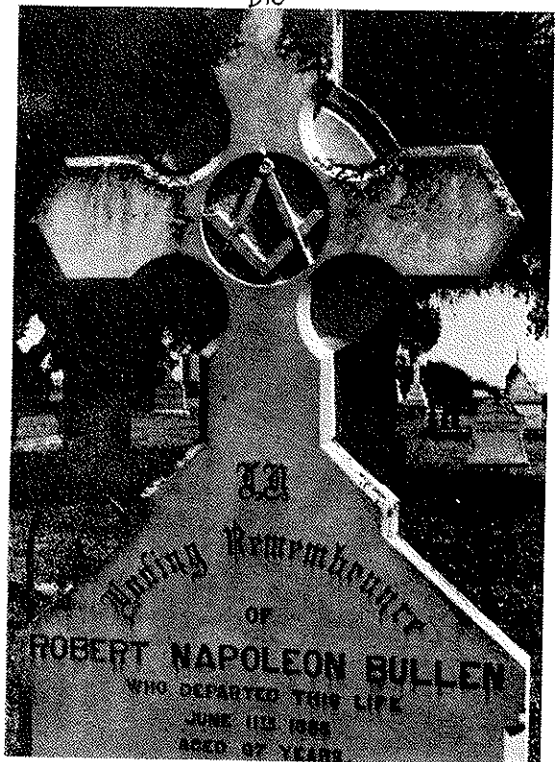

35-407 Robert Napoleon & Alice BULLEN
Solid Celtic cross, pointed ends;
masonic dividers and set square.

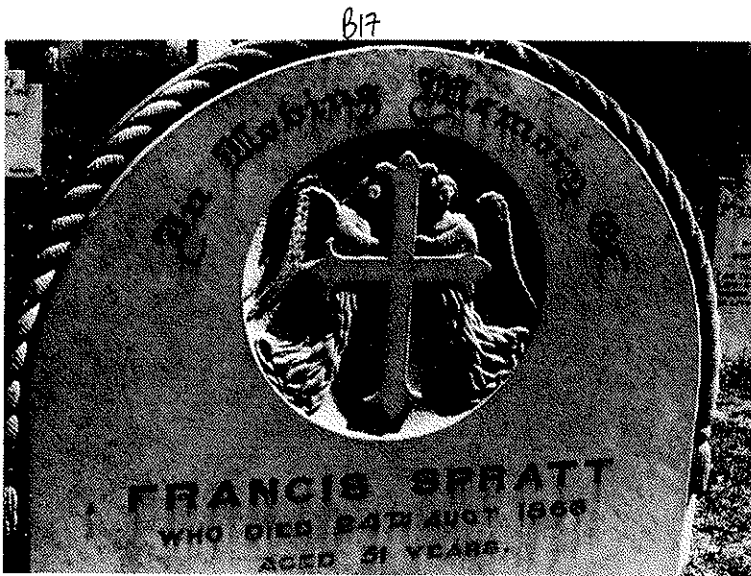

35-405 Francis SPRATT
Norman slab with tasselled rope over arch. Panel with cross and two angels.



34-384 Elizabeth & Joseph SMITH
Anthropomorphic slab. I.H.S. panel with sunrise. Small latin cross in each shoulder.



38-468 William COSTELLO Jr.
Gothic slab. Rustic cross with ivy in Gothic panel.



38-469 Patrick & Rose MCKINLEY
Rounded slab surmounted by sash. Floral decor along sides. Panel with dove and olive branch.

821



39-486 Margaret HOYNE & children
Gothic slab with ivy & shamrock decor.
Clasped hands.

822

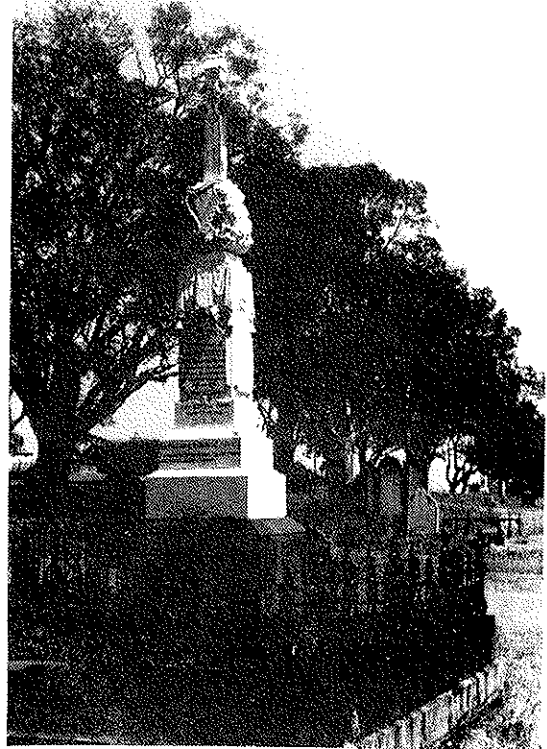

39-485 Patrick KELLY
Pedestal with altar cloth surmounted by
block with aeolian harp: above is celtic
cross capped by lych gate.

823



39A-484 Frederick Burns RICHARDS
Shouldered Norman slab; anchor with
ivy in panel.

824

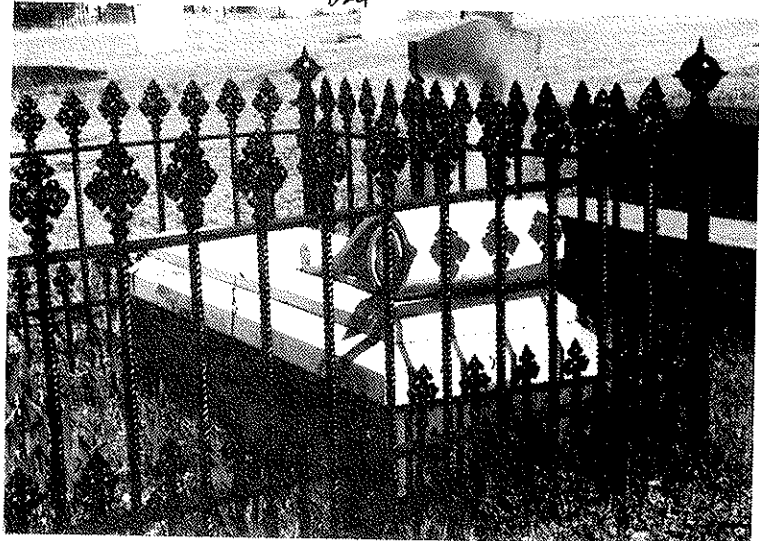

6-31C BIRCH
Altar monument with massive scroll:
inscription illegible.

825

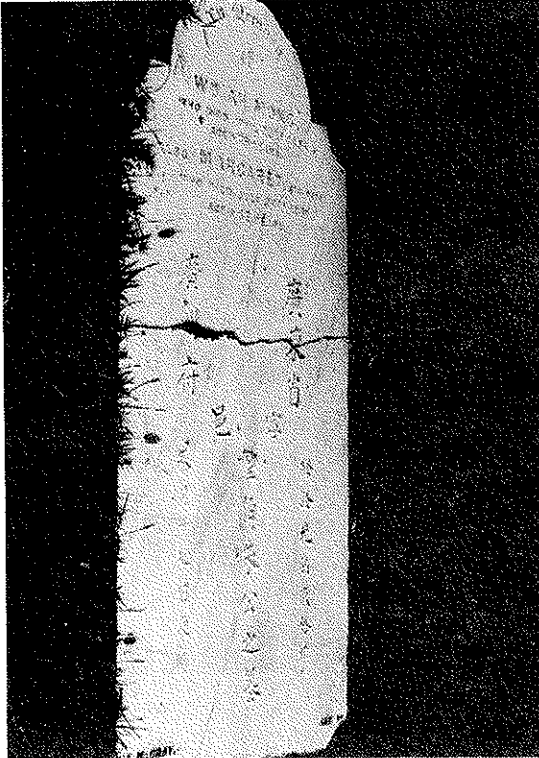

7-35 William & Margaret AH MONG
Norman slab: Chinese inscription.

826

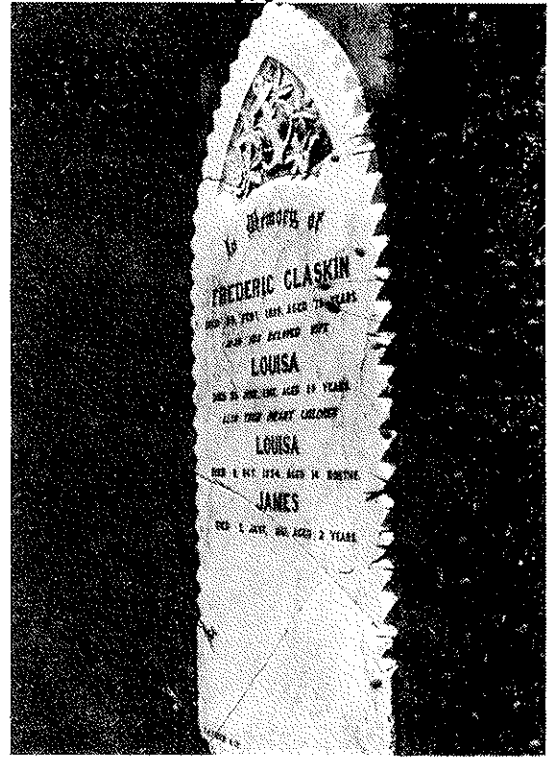

9-44 Frederick & Louisa GLASKIN and
children
Gothic slab; serated margin. Anchor &
passion flowers in panel.

827

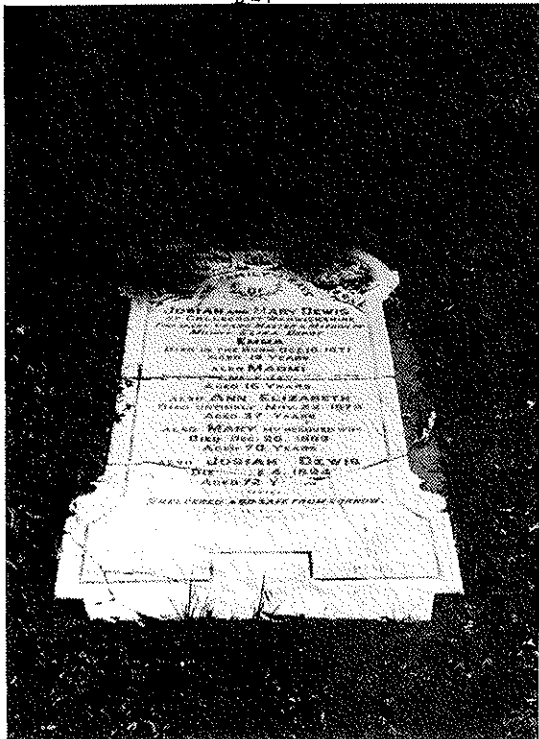

10-51 DEWIS family grave
Gothic-ogee with cross, scroll, ferns,
lilies and sash in panel.

828

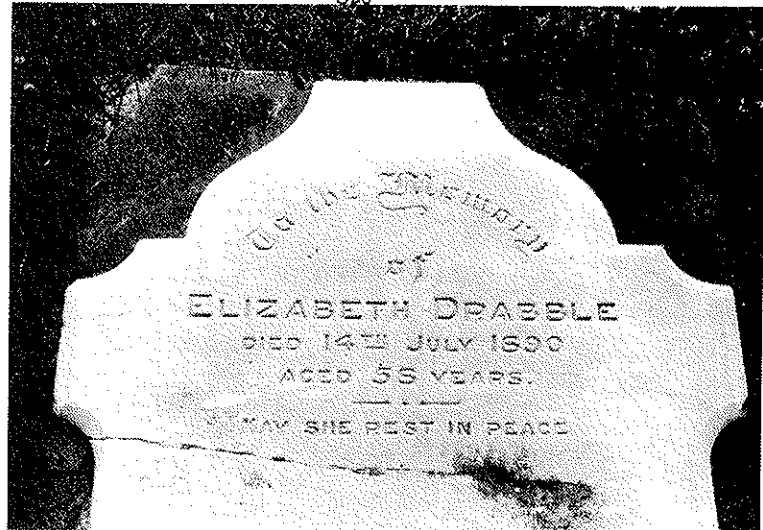

10-56 Elizabeth DRABBLE
Flanged slab.

B29



16-103 William & Hannah BUFTON
Rounded sandstone slab. Inscription
on west face.

B34

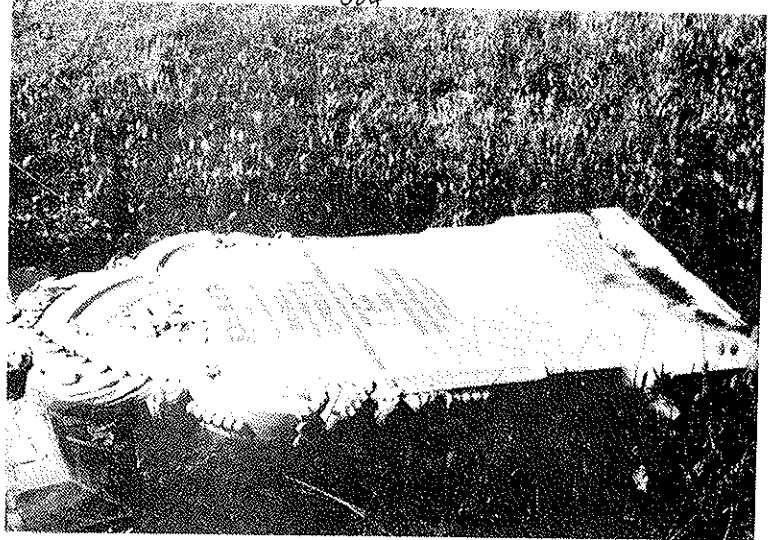

28-254 Bridget & Amy LEE
Shouldered Gothic slab; acanthus leaves
over crest. Top, probably cross (?)
missing.

B30

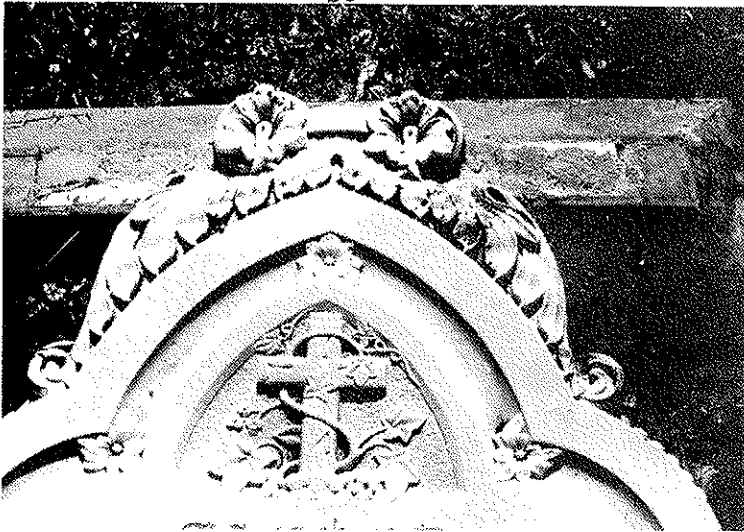

28-254 LEE
Details of acanthus decor; latin cross
with ivy in panel.

B32

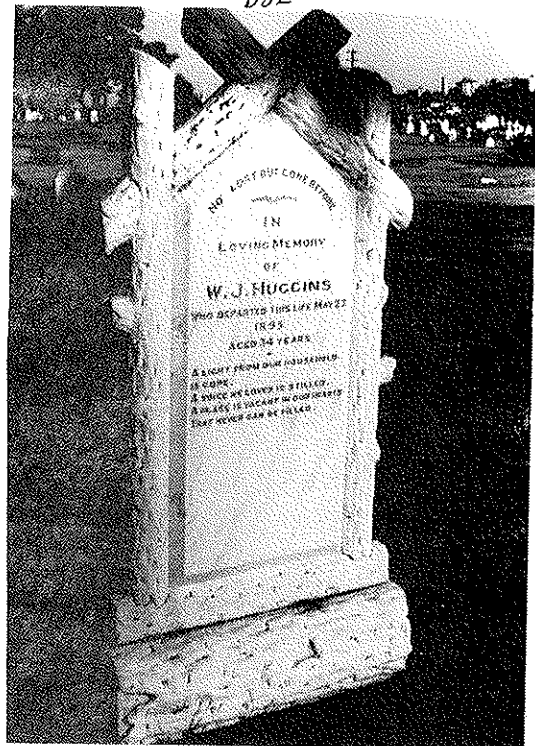

61-770 W.H. HUGGINS
Rustic gable monument with cut off tree
limbs.

B33

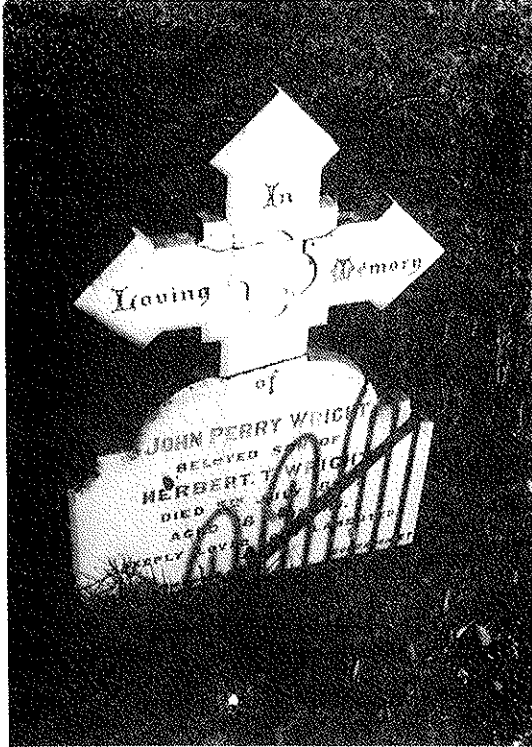

60-755 John Perry WRIGHT
Spear-ended cross; kneeling lamb in panel.

B34

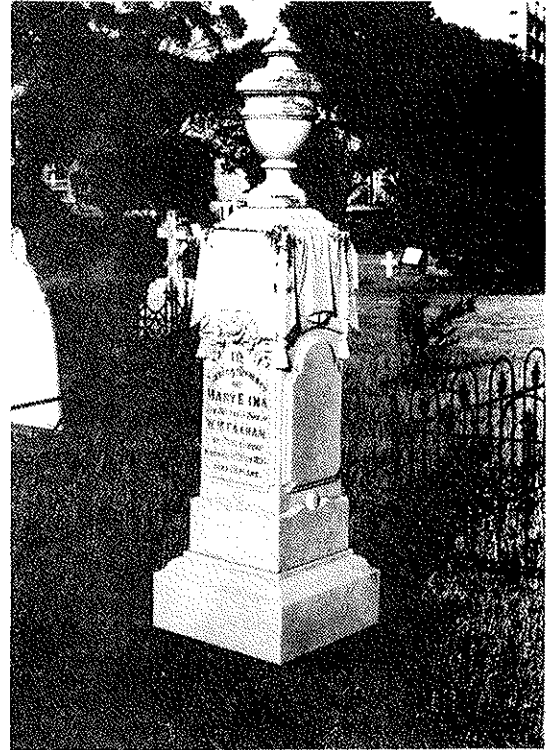

59-741 Mary Emma FAAHAN
Pedestal with altar cloth surmounted by large urn.

B35

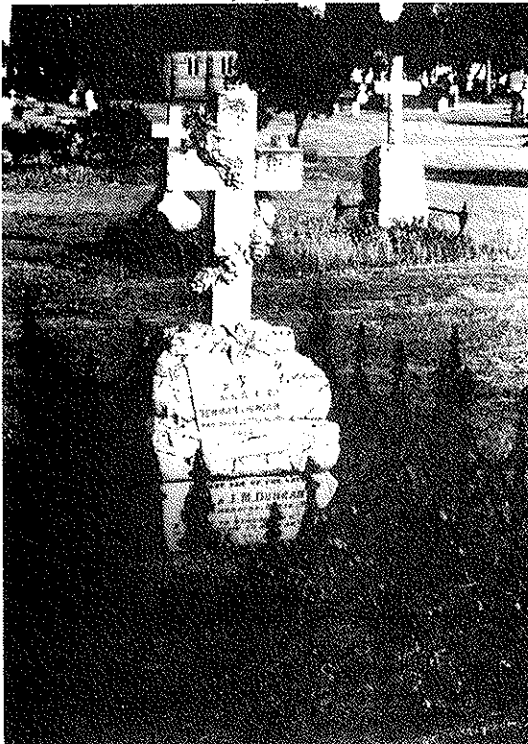

57-720 Leonard Alfred Newman DUNCAN
Calvary cross with rose decor on massive block with scroll.

B36



57-722 Edward FOX & William T. HARDING
Granite obelisk on square base.

B37



55-699 J.T. DENNY

Rustic cross with ivy decor on massive block with scroll.

C00

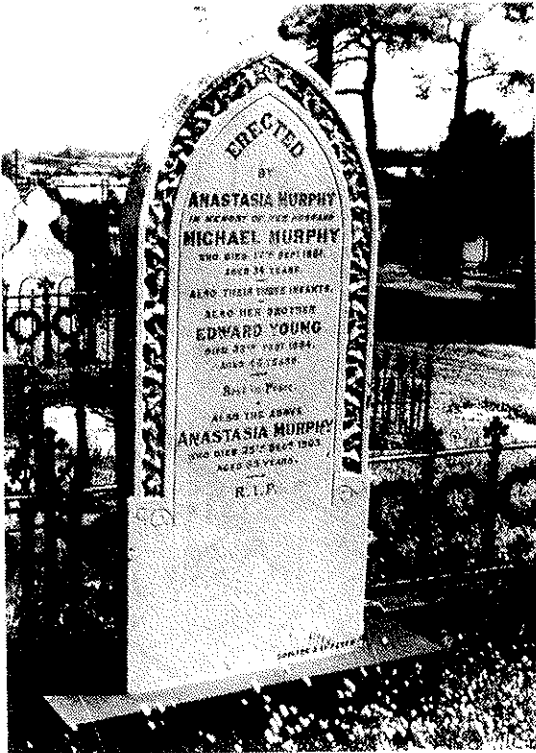

23-200 MURPHY; YOUNG
Gothic slab; ivy decor.

C0



23-199 Bernard; Bernard & Bridget KELLY
Gothic slab; panel with clasped hands and ivy decor.

C1



25-210 BOLADERAS; CORBETT
Castellated monument surmounted by avellan cross. Supplementary crosses missing.

C2



25-208 Catherine O'ROURKE
Calvary cross; I.H.S.

03



27-217 GUILFOYLE; CARR
Calvary cross; floral decor and plaited sash.

04



27-226 James Buchan MacLAGAN
Calvary cross with lily on massive block with scroll.

05

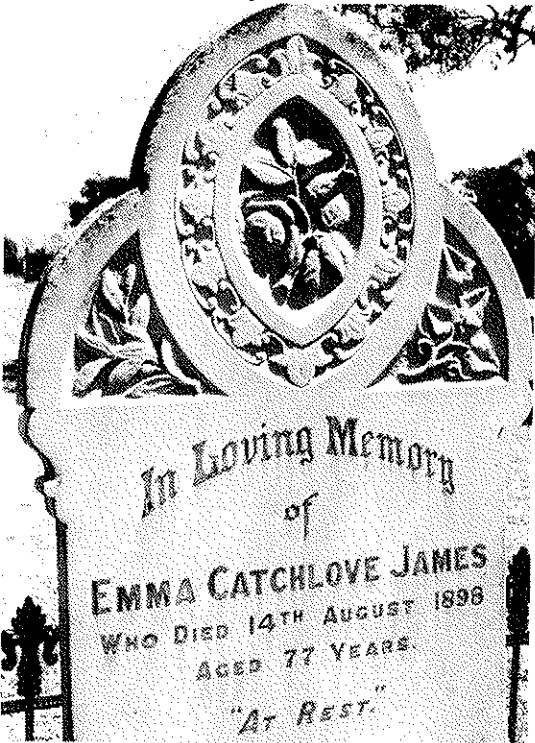

27-234 Emma Catchlove JAMES
Oval set in Gothic arch. Fleur de lis, rose, lily and ivy decor.

06

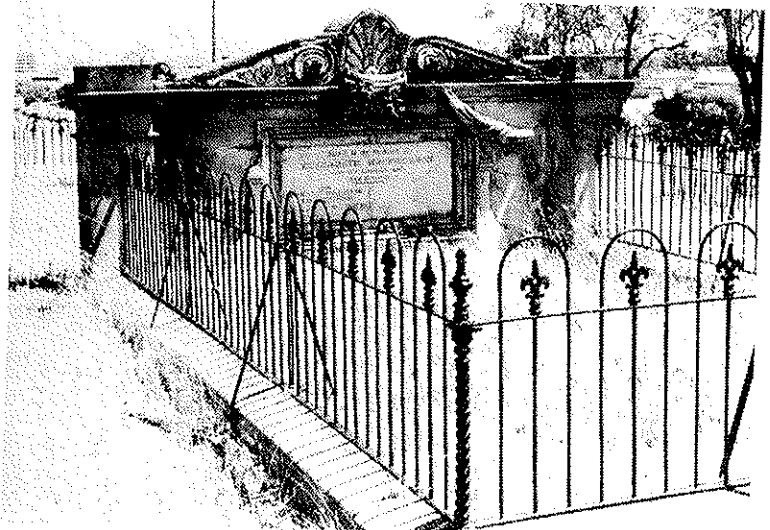

21-166 Elizabeth & Donald Graham MacPHERSON
Massive concrete monument: part of ornamentation lost.

C7



27-248 McKenzie GRANT
 Grey granite obelisk.
 27-249 John EDGAR
 Granite column with urn on three-tiered base.

C8

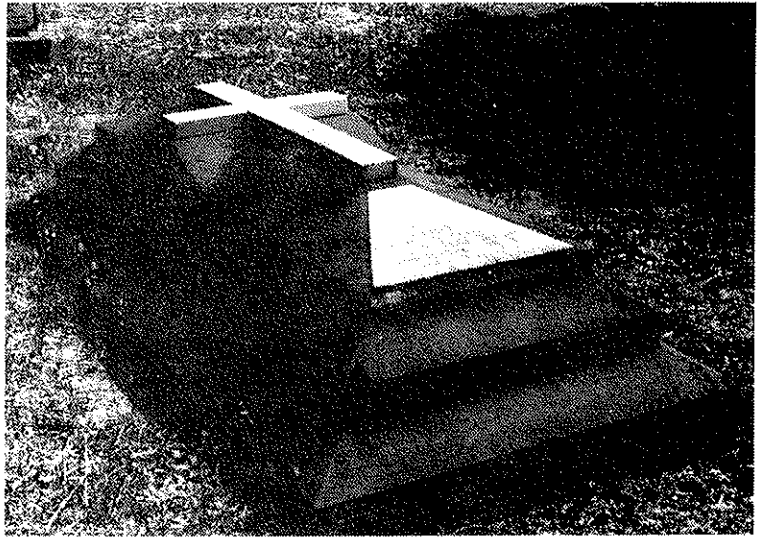

28-264 Margaret STABLES
 Marble latin cross on three-tiered base.

C9

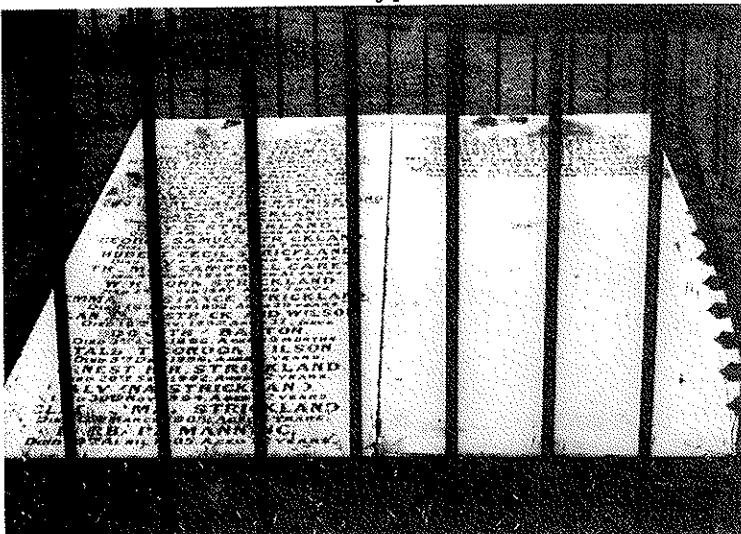

28-266 STRICKLAND vault
 Massive concrete slab capped by
 marble slabs: Book.

C10



28-275A Rev. John Burdett WITTENOOM
 and family
 Oblong concrete slab; inclined.
 28-275B Robert Mace WITTENOOM
 Marble block with anchor & chain
 surmounted by lopped off tree-bole with
 ivy decor.

C11

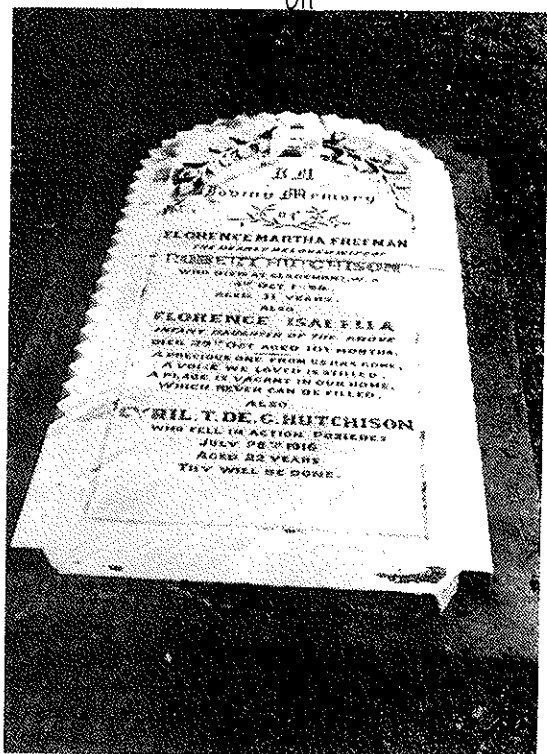

38-471 Florence Martha Freeman
 HUTCHISON et al.
 Norman slab with crenulate margin.

C12

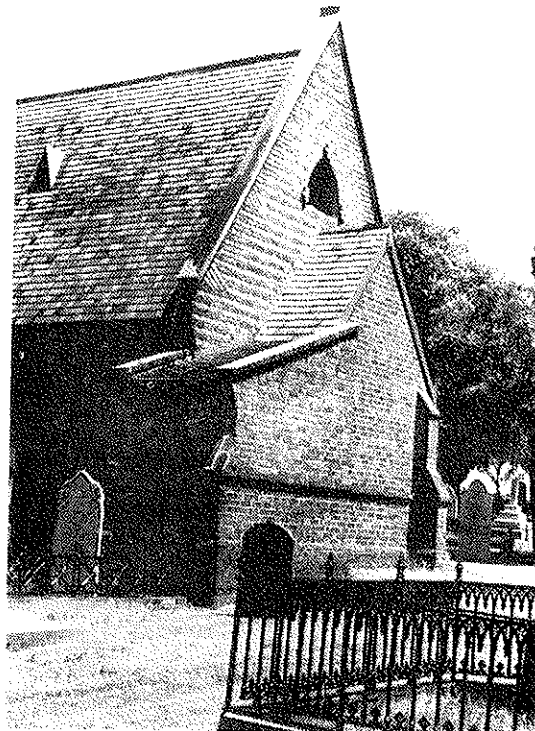

ST. BARTHOLOMEW'S CHURCH
 Anglican. Viewed from north.

C13

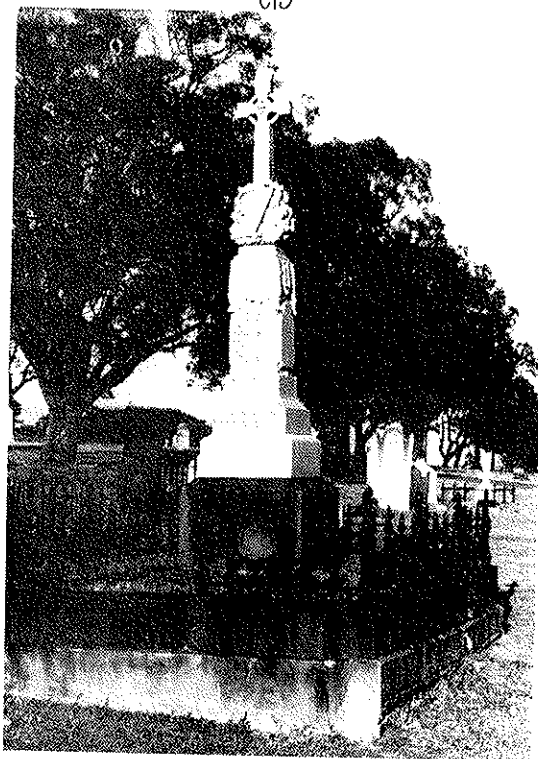

39-485 Patrick KELLY
 Pedestal with altar cloth surmounted by
 block with aeolian harp; above is celtic
 cross capped by lych gate.

C14

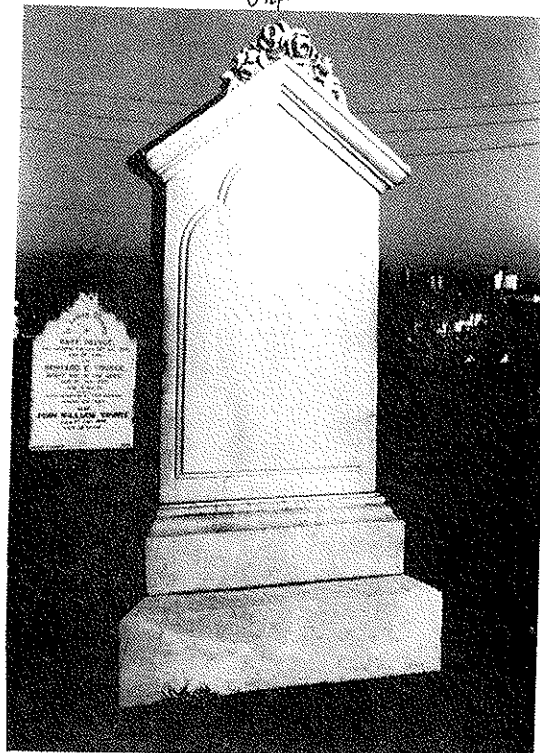

40-492 John SMITH
 Peaked slab with floral decor over peak.

C15

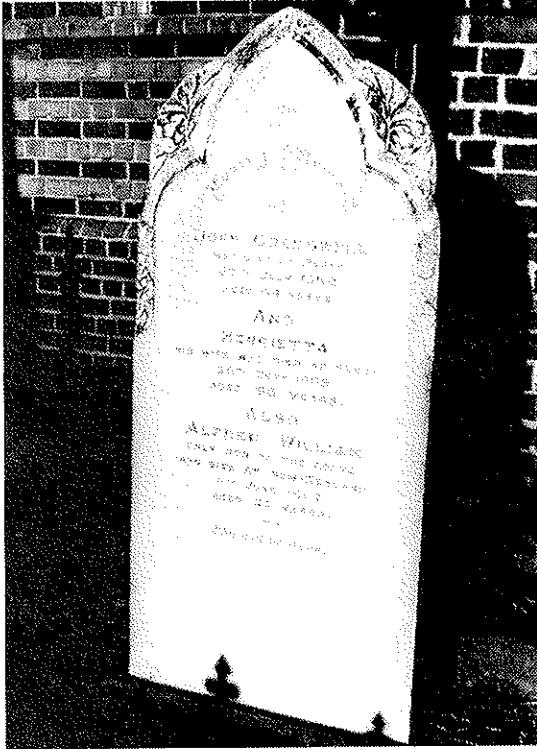

40-501 John, Henrietta & Alfred William CRESSWELL
Shouldered Gothic slab with madonna lily decor.

C16

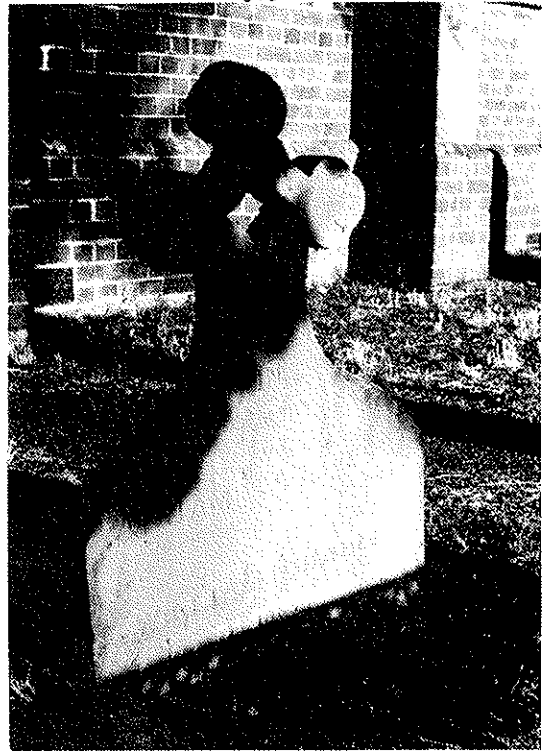

40-504 James & William Charles GRIEVES
"Shamrock" type cross in sandstone.

C17

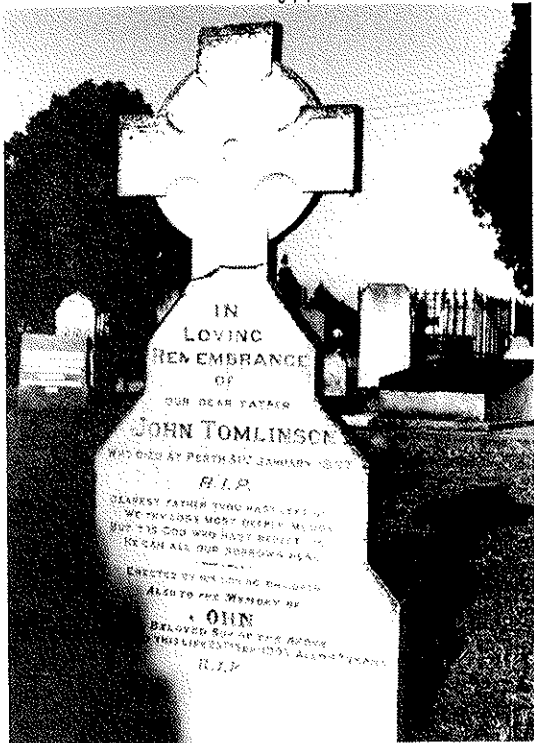

40-507 John TOMLINSON & son John
Solid Celtic cross.

C18



36-454A John Frederick STONE & son
Calvary cross with I.H.S. panel and passion flower decor.

C19



41-535 Florence Maud COCKRAM
Norman slab.

C21

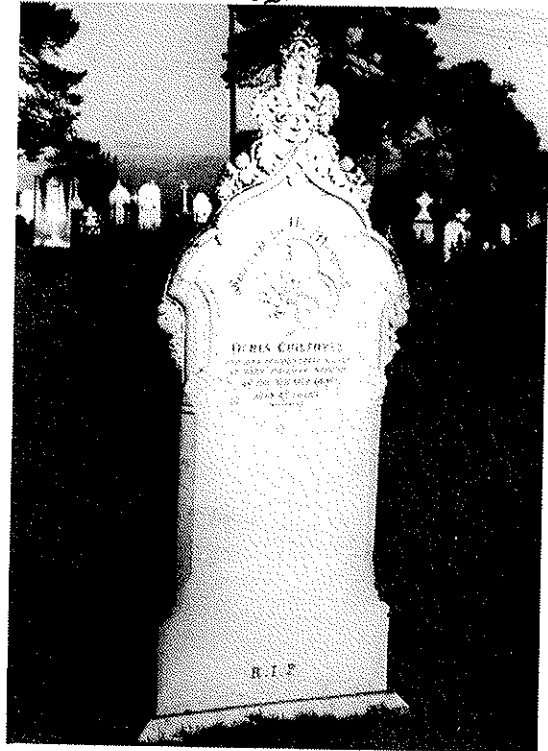

41-525 Denis GUILFOYLE
Gothic-ogee slab surmounted by elaborate
floral decor.

C20



43-559 Henry Charles HILLS
Pedestal with altar cloth, surmounted by
draped urn and wreath
43-558 Norah Louisa & John Charles STUART
Headstone: massive scroll with latin cross,
anchor & dove.
Footstone: small cross.

C22



47-622 James B. NOWLAND
Open Celtic cross with four pyramids
per segment.

C23



61-766 Angelina Elizabeth PRITCHARD
Gothic slab. St Andrew's cross with
ivy in panel.

C24

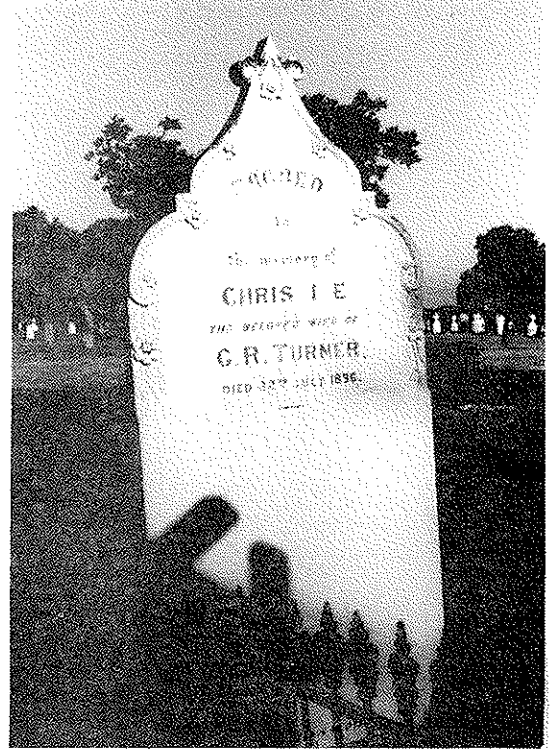

60-752 Christine TURNER
Ogee-gothic slab. Rose decor.

C25

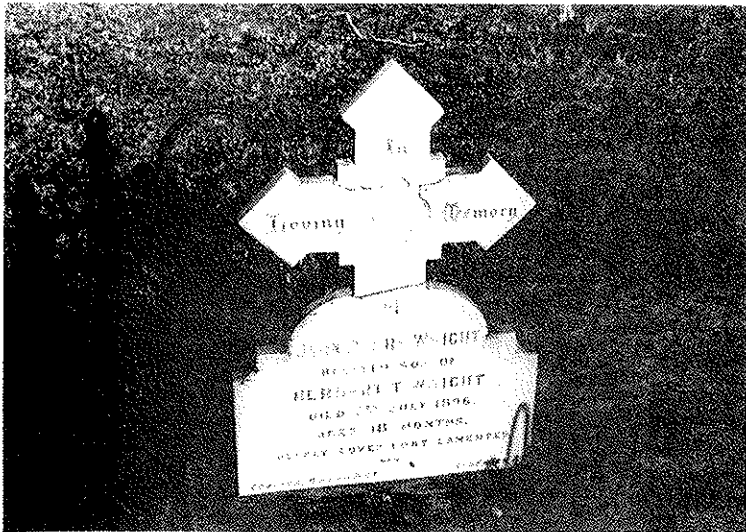

61-755 John Perry WRIGHT
Spear-ended cross; kneeling lamb in
panel.

C26

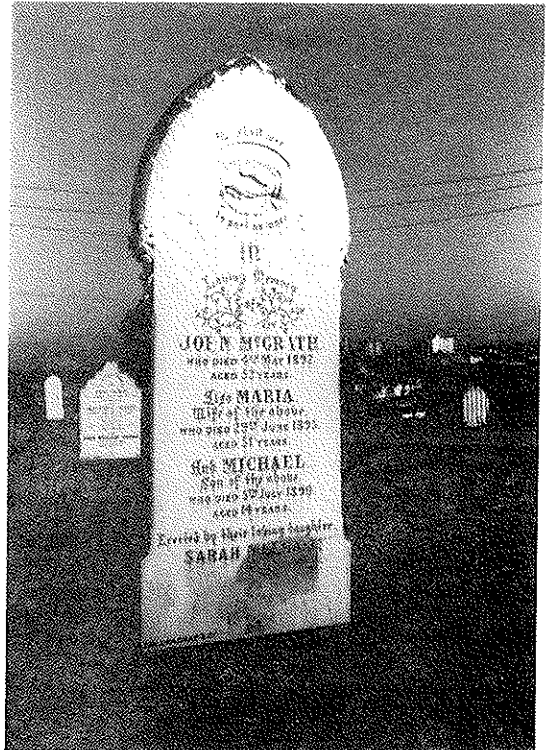

41-522 John, Maria & Mitchell McGRATH
Gothic slab. Clasped hands in panel.

C27



32-349 John CURRAN
Solid celtic cross; I.H.S. and shamrock decor.

C28

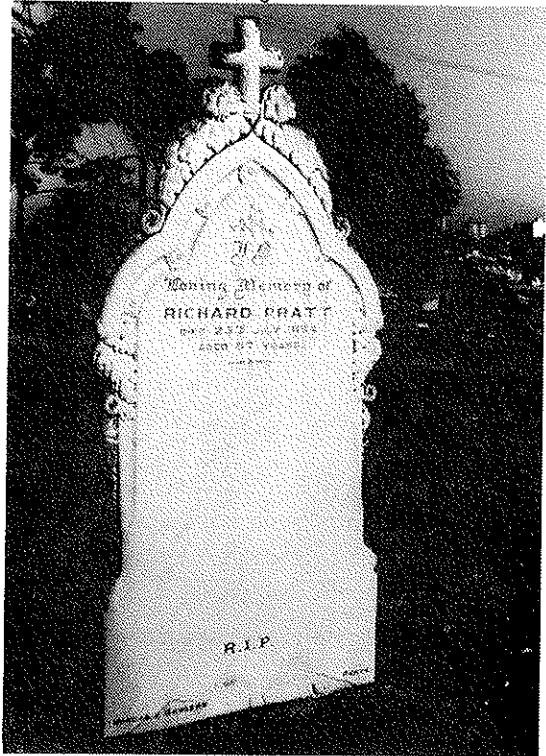

32-350 Richard PRATT
Shouldered Gothic slab surmounted by acanthus leaves and small latin cross.

C29

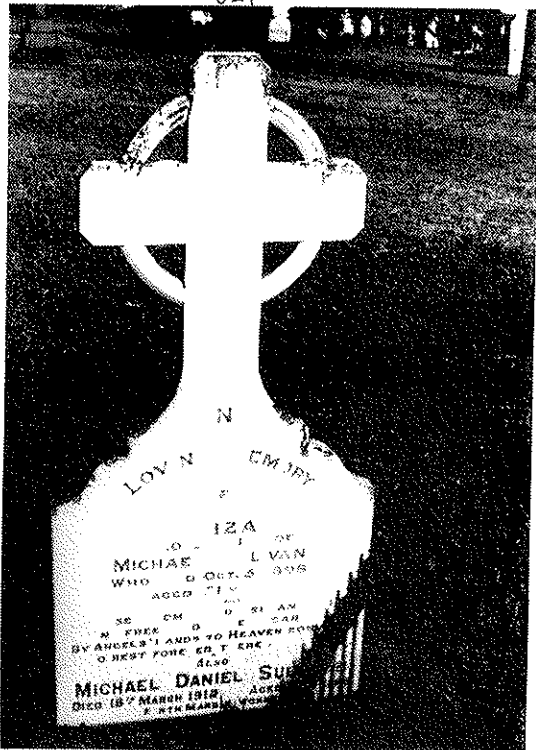

30-291 Eliza & Michael Daniel SULLIVAN
Open celtic cross.

C30

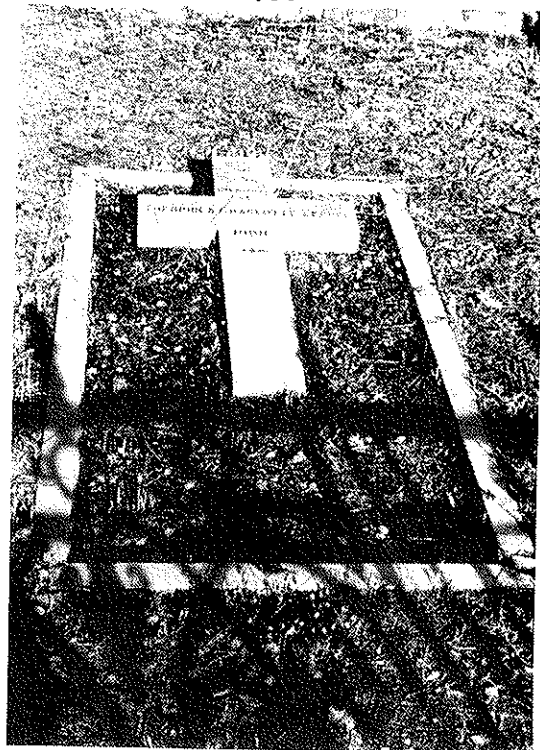

28-255 Theophila Charlotte LEEDER
Simple latin cross.

C31

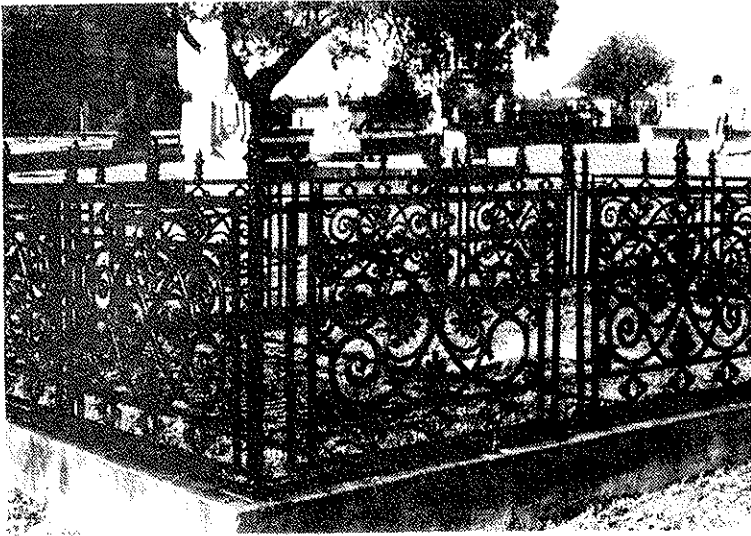

28-255 Theophila Charlotte LEEDER
Elaborate iron fencing surround to
gravesite.

C32

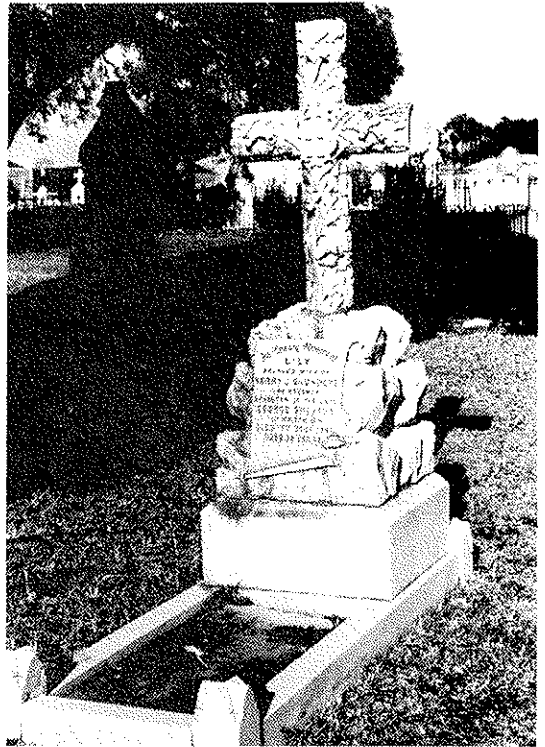

28-258 Lily SAUNDERS
Rustic Calvary cross; I.H.S. with
madonna lilies on massive blocks.

C33

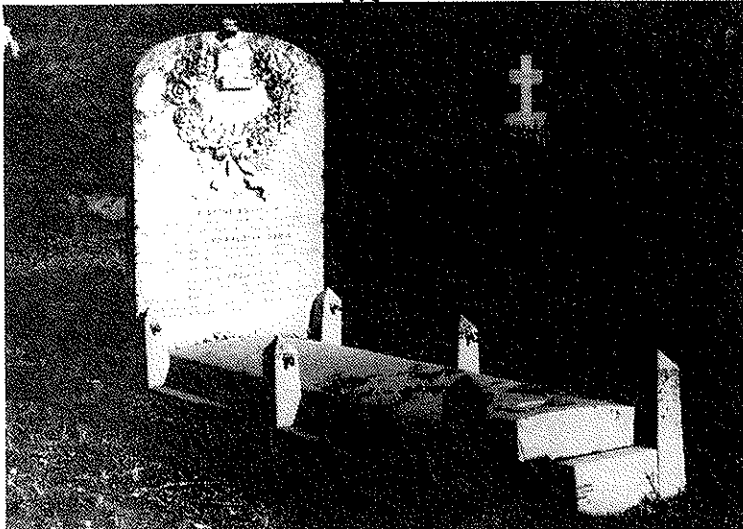

31-331 G.F. STONE, J.P & family
Round slab with wreath & sash & scroll.
Massive marble slab atop tomb.

C34



32-354 LEEDER; HICKS
Shamrock Celtic cross with madonna lily
panel.

C35

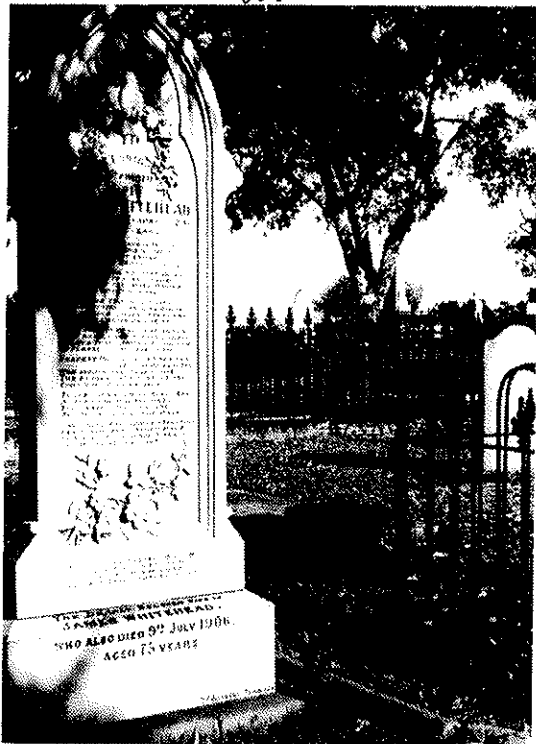

32-374 Eliza & James WHITEHEAD
Gothic arch; hand extending from heavenly cloud
and holding wreath.

C36



32-364 GOOCH; CAMERON
Elaborate iron fencing around site.

MAPS

S T R E E T

100	101	102	103	104	105	106	107	108	109	110	111	112	113	114	115	116	117	118	119	120	121	122	123	124	125	126	127	128	129	130	131	132	133	134	135	136	137	138	139	140	141	142	143	144	145	146	147	148	149	150	151	152	153	154	155	156	157	158	159	160	161	162	163	164	165	166	167	168	169	170	171	172	173	174	175	176	177	178	179	180	181	182	183	184	185	186	187	188	189	190	191	192	193	194	195	196	197	198	199	200
-----	-----	-----	-----	-----	-----	-----	-----	-----	-----	-----	-----	-----	-----	-----	-----	-----	-----	-----	-----	-----	-----	-----	-----	-----	-----	-----	-----	-----	-----	-----	-----	-----	-----	-----	-----	-----	-----	-----	-----	-----	-----	-----	-----	-----	-----	-----	-----	-----	-----	-----	-----	-----	-----	-----	-----	-----	-----	-----	-----	-----	-----	-----	-----	-----	-----	-----	-----	-----	-----	-----	-----	-----	-----	-----	-----	-----	-----	-----	-----	-----	-----	-----	-----	-----	-----	-----	-----	-----	-----	-----	-----	-----	-----	-----	-----	-----	-----	-----	-----	-----

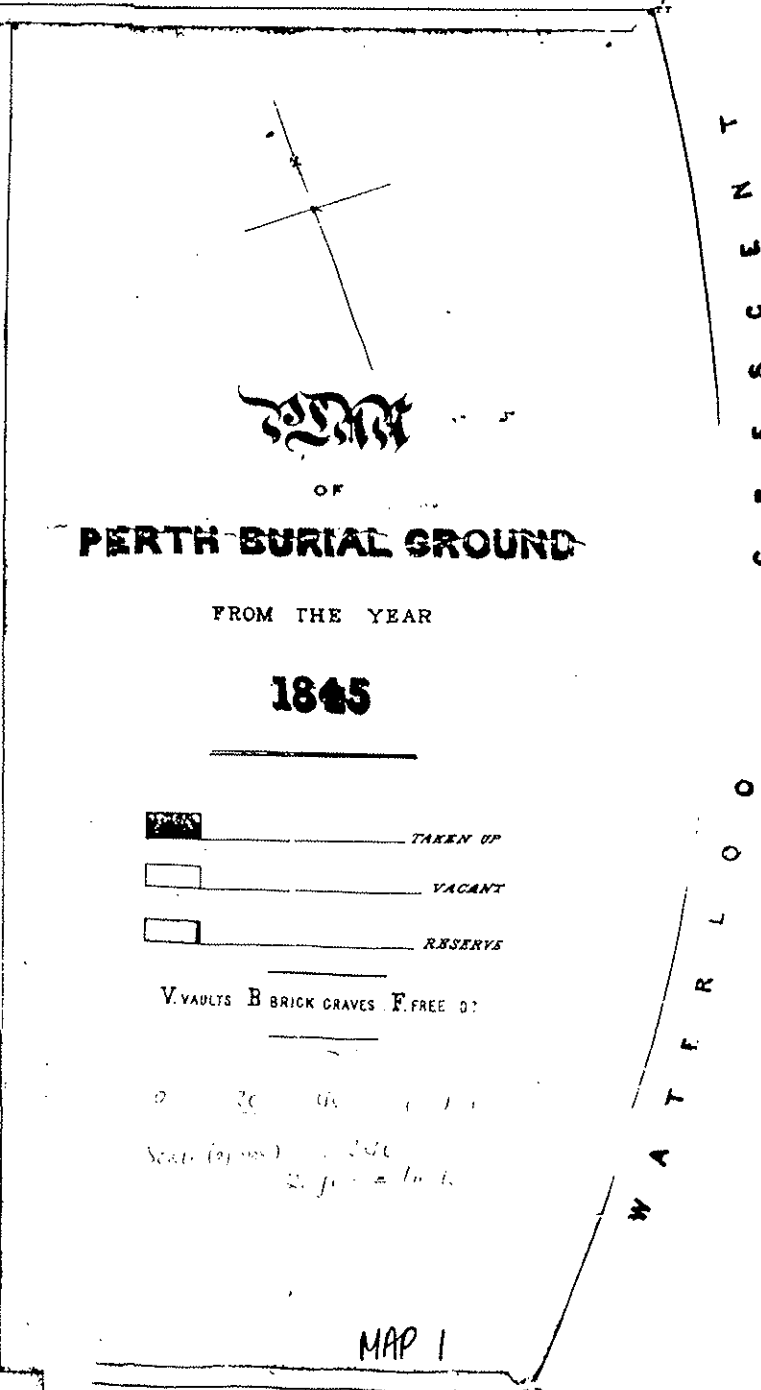

S T R E E T

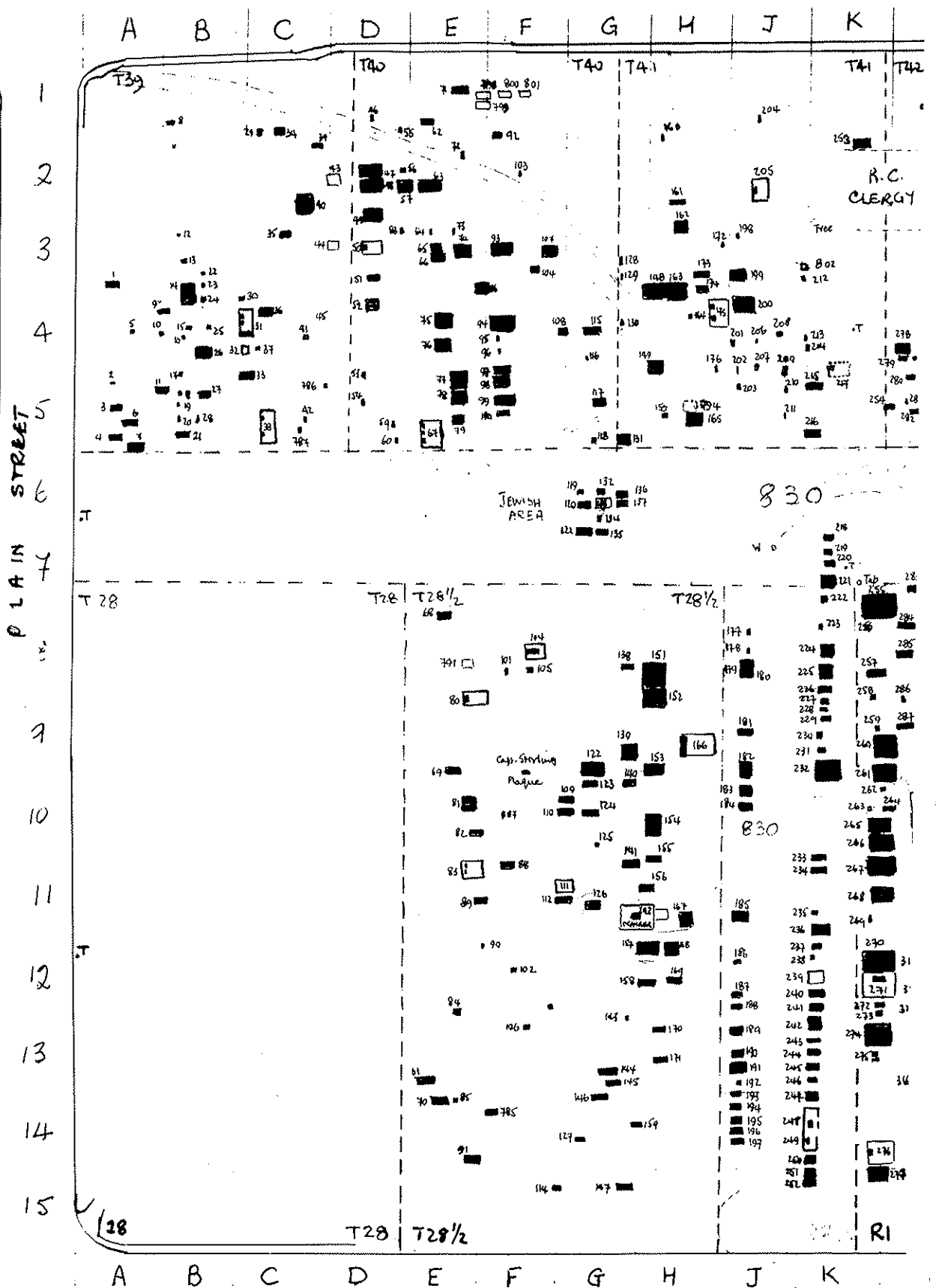

MAP

No. 2

- LOTS
 T39 Independent Church of Christ
 T40 Wesleyan
 T41-T44 Roman Catholic
 T28 1/2 Presbyterian
 830 (STH) Jewish
 R1 Anglican

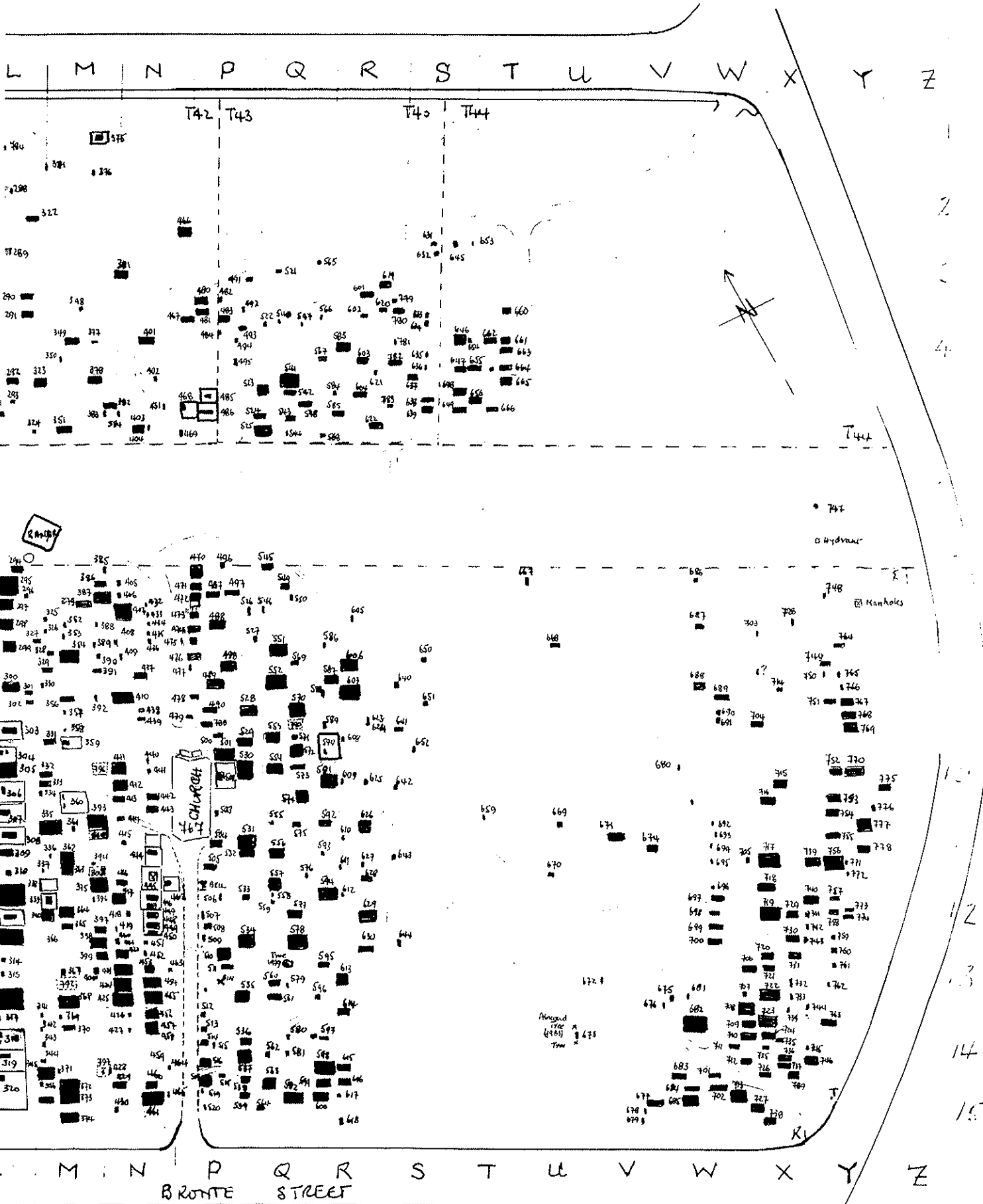

EAST PERTH CEMETERY: GRAVE SITES

BASED ON LANDS SURVEY DEPT AERIAL PHOTO S150 FILM WA Z174 C
DEC 1983

SCALE APPROX 1:470



P. Richardson
17 Dec 1985
Completed 24 Feb 1986

MAP 2.

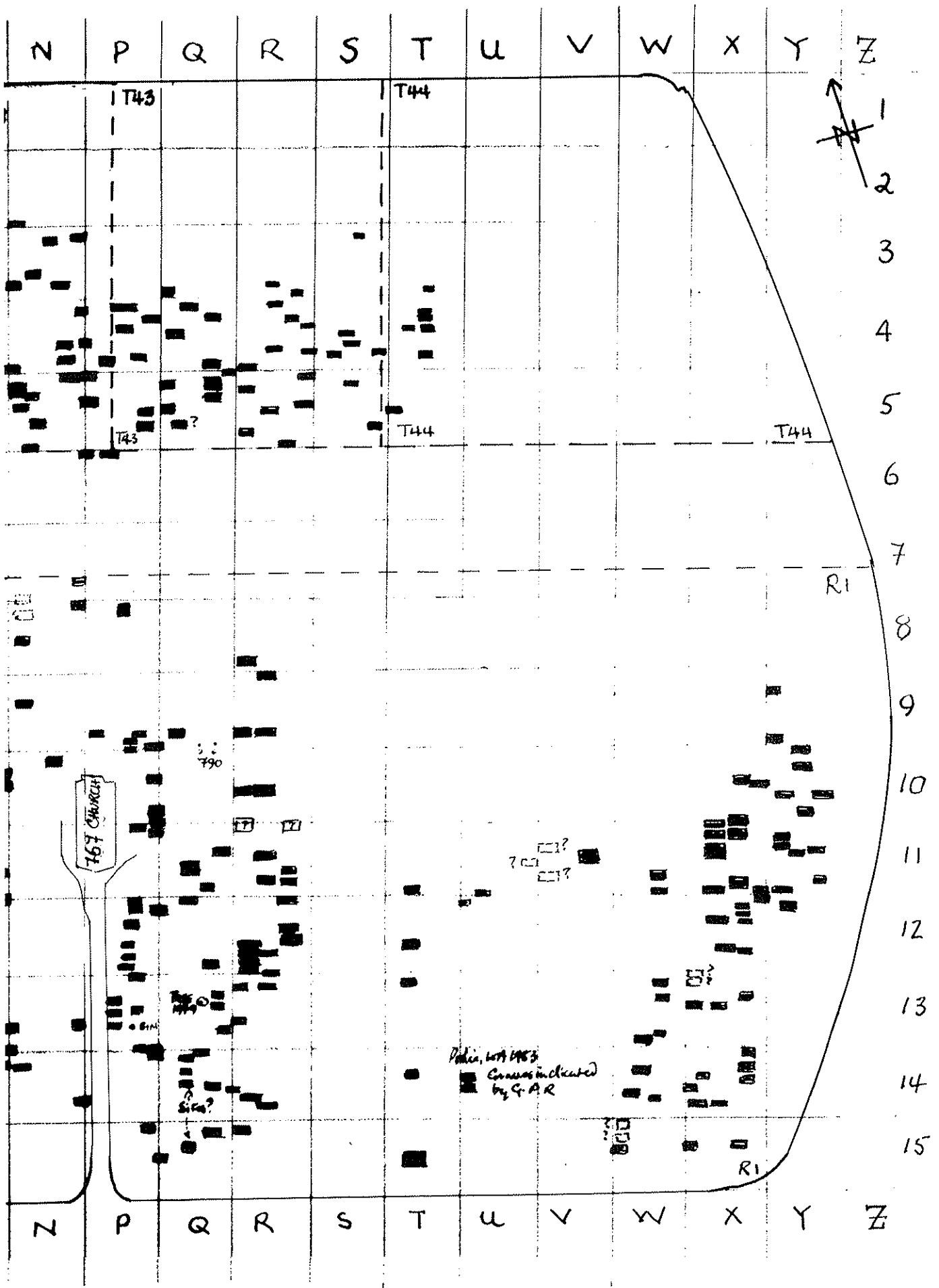

EAST PERTH CEMETERY: POSSIBLE GRAVE SITES

SURVEY: SEPT/OCT 1985 by D. DAVIES & J.A. RICHARDSON

SCALE: APPROX 1:470



largement A

A 115
PT Sub
DIA.

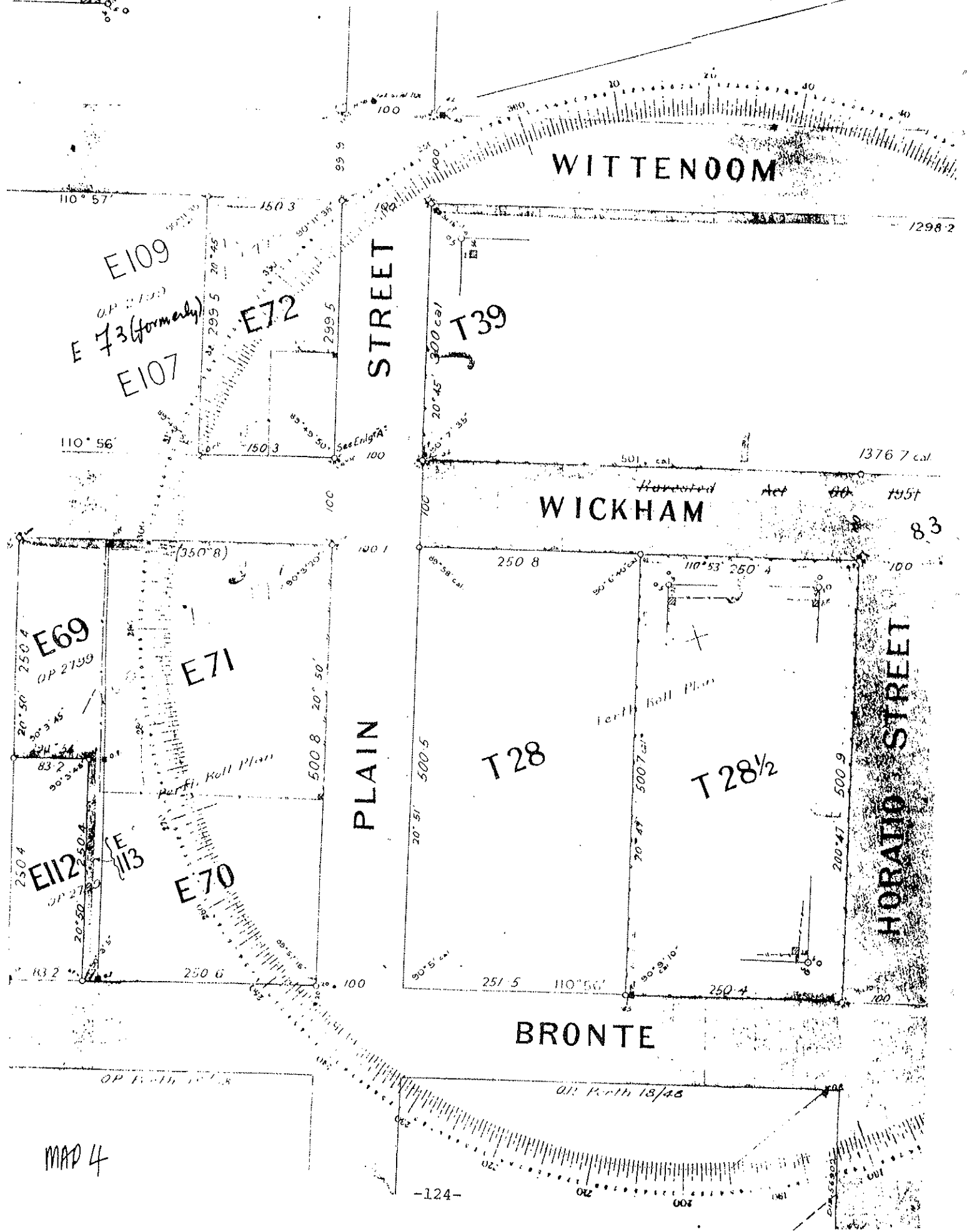

WITTENOOM

WICKHAM

STREET

PLAIN

HORATIO STREET

BRONTE

E109
E 73 (formerly)
E107

E72

T39

E69

E71

T28

T28 1/2

E112

E113

E70

MAP 4

5
Lot 4
81960

1259.6 cal. 110° 54' Dia 200.53

STREET

110° 54'

Perth Roll Plan

T44

110° 53'

875.7 cal.

Fence broken down

Curve 5612.60

STREET

801.9

110° 53'

RI

Perth Roll Plan

501 cal

707
Dia
43183

90° 9' 30" cal

165.1

110° 56'

STREET

6813 cal

LTO Dia 12.46

EAST PERTH CEMETERY

BEFORE RESUMPTION OF LOTS
WEST OF PLAIN STREET

PLAN 5126 ; 2.6.1939

MAP 4

0

100

200 FEET

(792)

ROAD

NILE

TRAFALGAR

WATERLOO CRESCENT

Account No. _____
Calculation Doc _____
Chainage class _____
Angular class _____
Area 11.7.16
Compared with _____
Examined _____

