



**FIELD
CORRESPONDENCE
COURSE**

MENSURATION — SECTION 2

**FORESTS DEPARTMENT
OF WESTERN AUSTRALIA**

FORESTS DEPARTMENT OF WESTERN AUSTRALIA

FIELD STAFF CORRESPONDENCE COURSE

MENSURATION

SECTION 2

INTRODUCTION

The measurement of individual trees and the growth of stands was discussed in Measurement Section 1. In this section we will examine :

SAMPLING IN FOREST STANDS

AERIAL PHOTOGRAPHIC INTERPRETATION OF FOREST STANDS

ASSESSMENT OF THE HARDWOOD FOREST AND PINE PLANTATIONS

RECORDS OF TRADE OPERATIONS

SAMPLING IN FOREST STANDS

For management purposes it is frequently necessary to obtain data about an area of forest such as the number and size of poles, the volume per acre or the number of regenerated seedlings. Usually, it is impossible to measure or count all the trees on the area, so sample plots are measured. From the information gathered from samples an estimate of the total value for the area can be made. The accuracy of this estimate will depend on where these samples are placed and how they are measured. The position of plots can be selected in the following ways.

Subjective Sampling

A forest is sampled subjectively when the position of plots is selected in the field. The problem with this sample is that it is biased. The assessor may unconsciously tend to favour a site with more or less trees, or place plots near roads which may be generally in gullies and therefore in one forest type. Alternatively, the assessor may try to overcome his bias by locating all plots away from roads.

Selecting the position of plots by sticking a pin in a map blindfold or throwing darts at a board is called haphazard sampling. This method of locating plots is also biased, because the tendency may be to stick the pins in the centre of the map.

Although subjective samples are not acceptable if we must be scientifically correct, quick samples are often required and plots selected subjectively by the assessor may give satisfactory results. An example is a plot to check basal area when thinning pines. Methods commonly used to reduce bias due to the human factor when selecting these plots are to throw a stick over the shoulder and place the centre of the plot where it lands, or think of two numbers at random and pace these distances from the corner of a compartment.

In many cases where the forest is variable and the assessor knows the area a better estimate of the total on the area is obtained when plots are consciously placed in areas which he knows to be average for the area. This is usually done when carrying out quarterly assessment. Although these estimates may be acceptable in certain cases, always remember that they are biased and because of this there is no means of gauging how close the total value obtained by these measurements is to the true value for the area. To overcome this problem one of the methods of objective sampling is used.

Objective Sampling

By sampling objectively the personal factor is eliminated or at least, greatly reduced.

Random Sampling

Plots are selected by placing a grid over the area and the centre point of the plot is selected by the use of random number tables. See Appendix I.

Example : Fig. 1 is an area of forest to be sampled by measuring five plots.

Fig. 1 :

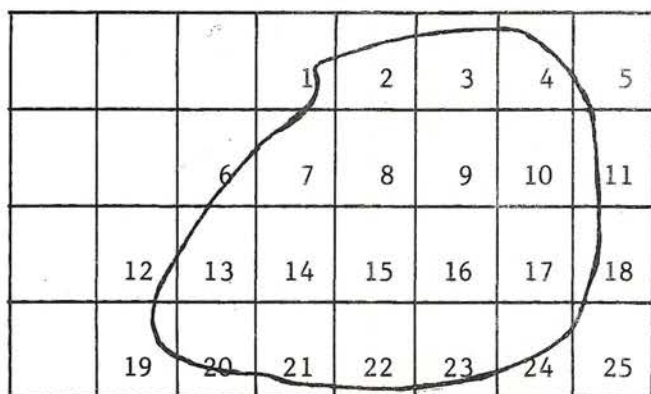

Place a grid over the area and number each square containing a portion of the area. Commence reading the random number table in Appendix I to select the position of the plot from any point and in any direction. In this example I have commenced to read the table across the page from the ninth row down and the third column in. The first pair of numbers is 16, so the plot will be in square 16. The next pair of numbers is 25. Use these to pinpoint the centre of the plot more accurately by working as you would to find a six figure map reference; 2 units across and 5 units up in square 16. This point is the centre of plot 1. The next pair of numbers is 15. Move to square 15 and pinpoint the centre of plot 2 with the next pair of numbers, 51. The next pair of numbers is 54. There is no square numbered 54, so reject this number and move on to the next pair 44, which must also be rejected. Continue until a number is read which need not be rejected. Any number of plots can be selected by this method.

Once the centre points of plots have been randomly located on a map the position of the plot in the field can be established by surveying from the nearest known point such as a reference tree or location corner. Remember that when selected randomly, plots can be anywhere. It is possible that by chance they may all fall in one small corner of the area to be assessed. Because they are randomly selected does not mean that they will be fairly evenly scattered over the area.

Systematic Sampling

Plots are positioned on a grid pattern at set distances along lines which are set distances apart. See Fig. 2.

Fig. 2 :

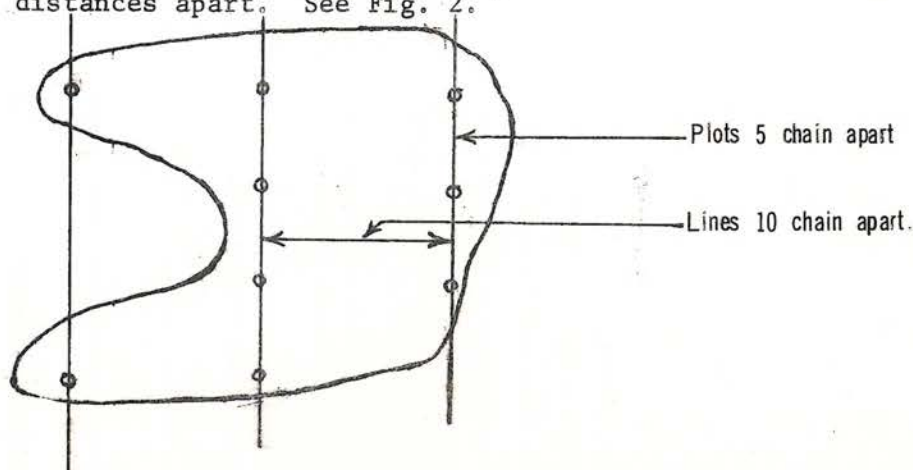

Once the first plot has been located the position of the others is fixed, so that this is an objective sample. Stripline assessment of the forest is also a systematic sample if the position of the stripline is first marked on a map, then accurately located in the field.

When to Use the Different Sampling Methods

Only locate sample plots subjectively if a quick approximate estimate of the total on the area is required or the area is very well known. Remember that such samples are biased and there is no way of measuring how reliable results obtained from them are. As a general rule it is better to use objective sampling methods.

Systematic sampling is usually quicker than random sampling because the plots are more easily located. However, this method has limitations because statistical calculations are based on random samples, so that not as much information can be extracted from the data collected. Whether these limitations are important or not will depend upon the use to which the data will be put. If a simple assessment of the number of trees, or the volume on an area is required then a systematic sample is probably the best. If it is thought that statistical mathematics will be applied to the data a random sample will probably be required.

AERIAL PHOTOGRAPHIC INTERPRETATION OF FOREST STANDS

How Aerial Photographs are Taken

Aerial photographs are taken for the Lands Department from aircraft which fly at approximately 8,000 feet to cover the area on a military map sheet; for example Collie, Dwellingup or Pemberton. The photographs are taken on a grid pattern and runs are flown from west to east. Approximately 12 runs, with 30 photographs per run cover a military map sheet. A photograph can therefore be identified by the name of the military map sheet, the number of the run and the number of the photograph (Example - Pemberton, Run 5, Photograph 0732).

Photographs within runs are taken so that they overlap by approximately 60%. Any three consecutive photographs should have about 20% overlap. See Fig. 3.

Fig. 3 :

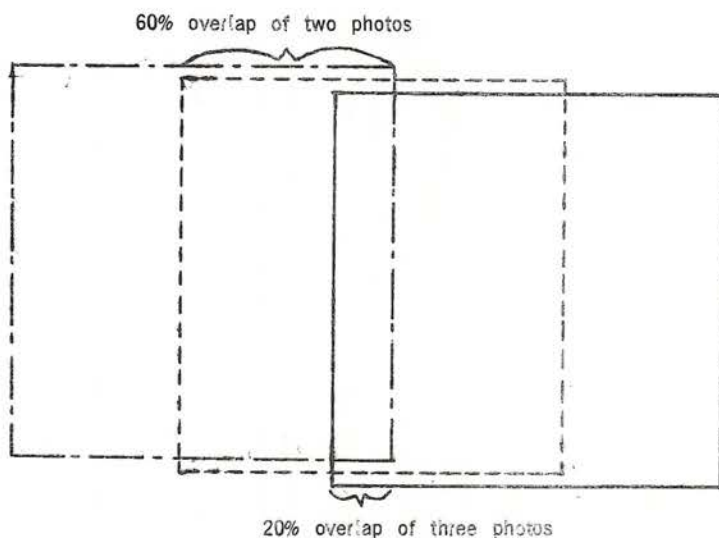

Photographs between runs must overlap by approximately 25%. The reason for the overlap is that any point on the ground must appear on at least two photographs. A pair of photographs can then be examined through a stereoscope to give an impression of a third dimension - depth. See Fig. 4.

Fig. 4 :

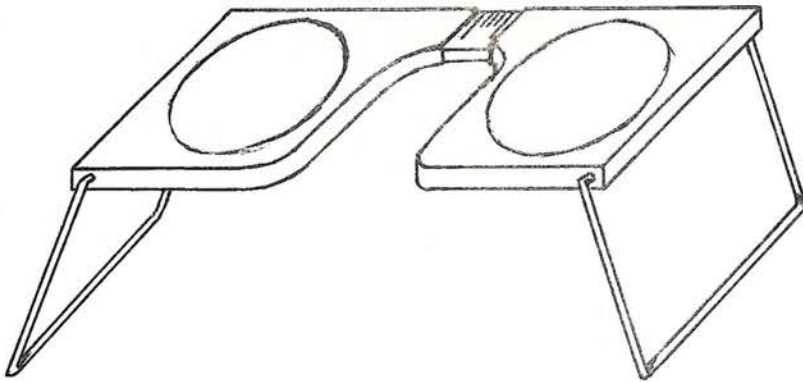

Depth can be appreciated if an object is viewed from two angles. In normal vision we are able to appreciate distance and depth because we have two eyes. Each eye sees the object from a slightly different angle and the images are processed by the brain to give a three dimensional picture. See Fig. 5.

Fig. 5 :

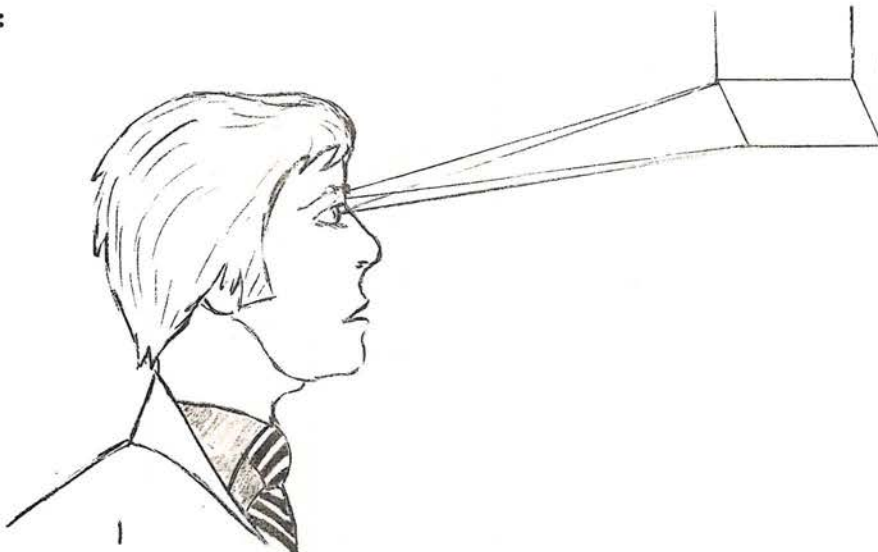

This principle applies to the examination of a pair of photographs through a stereoscope. The object can be seen in three dimensions because it is viewed from two different angles, and because the photographs are taken from different points above the ground. See Fig. 6.

Fig. 6 :

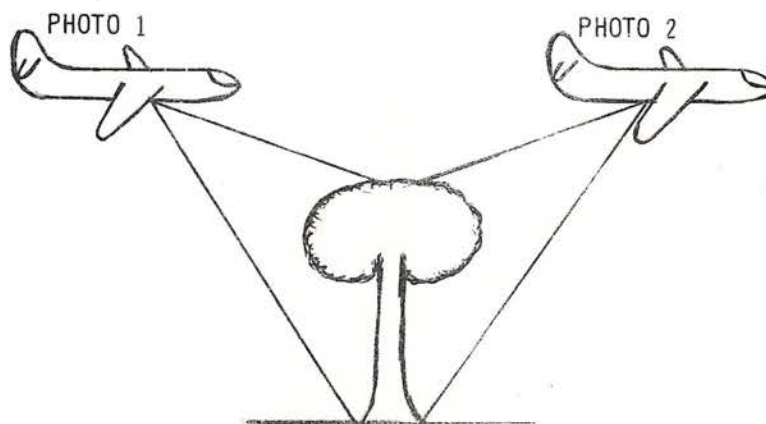

The ability to see a three dimensional image of the photographs is an advantage because the heights of trees can be appreciated, ridges and gullies can be easily seen, and shadows can be separated from trees. Time will be spent on a training day looking at aerial photographs through a stereoscope.

Aerial Photographic Interpretation of Natural Forest

As well as providing information about the position of features such as roads, creeks and forest boundaries, aerial photographs can be interpreted to give the following information about a natural forest stand.

- (i) Species composition
- (ii) Crown density
- (iii) Height

Sometimes this information cannot be obtained with certainty from the aerial photographs, so field checks are necessary. This is especially so when determining the species composition of a stand.

In Western Australia the forest is classified on the following characteristics, which can be seen on the aerial photographs.

- (a) Stand structure
- (b) Total stand density
- (c) Upper strata density
- (d) Species composition
- (e) Height classes
- (f) Other silvicultural factors as required

(a) Stand Structure

Two stand types can be recognised.

- (i) One layered stand
- (ii) Two layered stand

A one layered stand is described as a massed stand (abbreviated to "M" on A.P.I. sheets). This stand has no clearly recognisable lower strata, only an upper strata where the general canopy level is occupied by mature trees of co-dominant height. The stand is composed mainly of trees of saw-log size.

Before discussing two layered stands tree types must be defined.

- (i) Sawlogs - all trees greater than 60" g.b.h.o.b.
- (ii) Piles - all trees greater than 36" g.b.h.o.b. but less than 60" g.b.h.o.b.
- (iii) Poles - all trees greater than 18" g.b.h.o.b. but less than 36" g.b.h.o.b.
- (iv) Saplings - all trees less than 18" g.b.h.o.b.

A two layered stand can be divided into two types.

- A. A "P" stand. A stand usually with less than 40% crown cover in the upper strata and with a definite understorey of poles.
- B. An "S" stand. A stand usually with less than 40% crown cover in the upper strata and with a definite understorey of saplings.

(b) Total Density

Is the percentage of the ground covered by the tree crowns when looking directly down on the stand. The density classes marked on maps and the range to which they apply are listed below.

Density Class	Range
50%	50 - 59%
60%	60 - 69%
70%	70 - 79%
etc.	etc.

(c) Upper Strata Density

Is the percentage of the ground covered by trees of the upper strata. These crowns will normally belong to trees in the sawlog and pile size classes. The subdivisions of upper class density and the range to which they apply are listed below.

Upper Strata Density	Range
0%	0%
1%	1 - 5%
6%	6 - 19%
20%	20 - 29%
30%	30 - 39%

(d) Species Composition

Species are coded in the following way.

Jarrah	J
Karri	K
Marri	M
Wandoo	W
Blackbutt	B'tt

The presence of a tree species will not be recorded on an A.P.I. map unless it constitutes more than 20% of the stems in the stand bigger than 12" g.b.h.o.b. The most common species is written first.

Examples

80%J, 20%M	= JM
60%M, 40%J	= MJ
80%J, 10%W, 10%M	= J
50%J, 30%K, 20%M	= JKM
50%J, 40%W, 10%M	= JW

(e) Height Class

Is based on the average co-dominant height of the stand.

Fig. 7 :

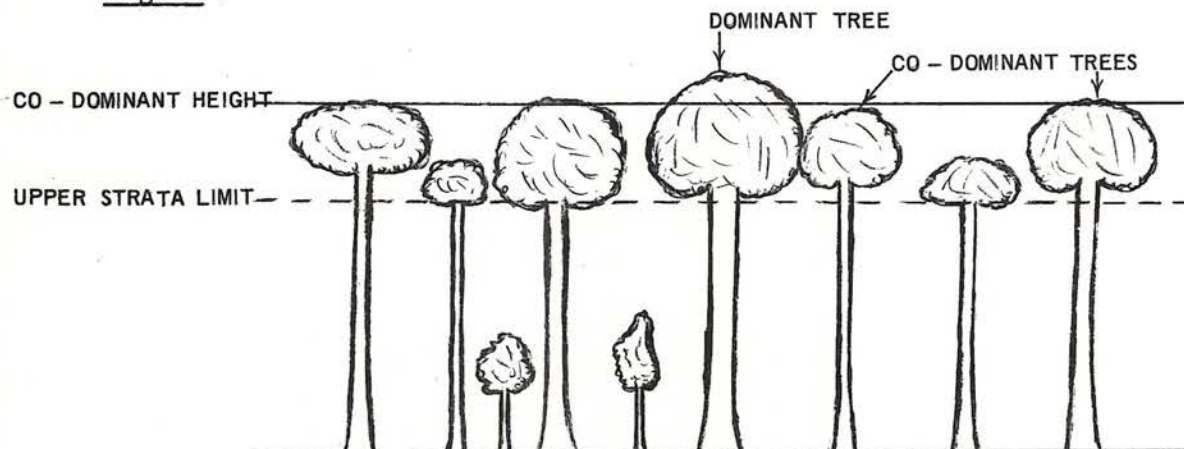

The symbols used to classify stands into height classes are as follows :

Karri (and Tingle)	Jarrah (and M, W, B'bt)
A 170+'	A+ 110+'
B 130-169'	A 90-109'
C 90-129	B+ 70-89'
	B 50-69'
	C less than 50'

(f) Other Silvicultural Conditions

Recorded on A.P.I. maps are abbreviated as follows.

D'b	dieback
F'd	fire damage
Sc	thick scrub present
DEC	decadent crowns
V	virgin forest

Expressing Forest Types

The forest is classified on the characteristics that have been described; each different area is given a forest type. This is expressed as follows.

(a) One Layered Stand

(Species) (Height Class) (Stand Structure) (Total Stand Density) (Silvicultural Condition).

Example: JMB+ M70 F'd

Description

- (i) The principle species is jarrah which occupies between 40-80% of the stand.
- (ii) The secondary species is marri which occupies between 20-50% of the stand.
NOTE : There could be a third species (K, B'bt or W) which occupies up to 20% of the stand.
- (iii) The co-dominant height of the stand is 70-89'.
- (iv) The stand is a one layered stand consisting of trees of pile and sawlog size. There is no clearly separable lower strata.
- (v) Upper strata density lies between 70-79%.
- (vi) The stand is fire damaged.

(b) Two Layered Stand

(Species) (Height Class) (Stand Structure) (Upper Strata Density) (Silvicultural Condition) (Total Stand Density).

Example : 30
JA+ P60

Description

- (i) The principle species is jarrah occupying between 60-100% of the stand.
- (ii) The co-dominant height of the stand is greater than 110'.

- (iii) Stand structure is a two layered forest, the upper strata composed of piles and sawlogs with a clearly separable lower strata composed mainly of poles. There will probably be some saplings.
- (iv) The total stand density is between 60-69%.
- (v) The upper strata density is between 30-39%.
- (vi) By subtraction the lower strata density lies between 30-39%.

Use of A.P.I. Maps

Maps produced from aerial photographs interpretation can be used for a variety of purposes. The following are a few of the main uses.

(i) Assessment

Before assessment, an area is often divided into strata, (areas of forest which are similar.) For example the strata selected may be :

- Stratum 1 all J and M areas
- Stratum 2 all M and K areas
- Stratum 3 all K and M areas
- Stratum 4 other areas, B'bt, flats etc.

A better estimate of the total volume on an area is obtained when each stratum is sampled separately. The volume in each strata is obtained by multiplying the average volume per acre of the sample plots by the total acreage of the strata. The total volume on the area can then be obtained by adding the volume in each strata.

An example will illustrate this. In the area shown, strata A is high quality forest and strata B is a flat carrying a low volume per acre. By random selection three plots fall in strata A and two in strata B. This is desirable since strata A is more valuable and should be more closely sampled. However, if the area is not stratified the total volume is calculated as follows.

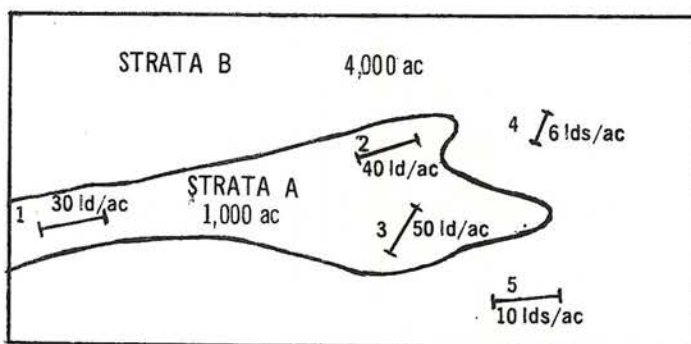

Area Not Stratified

$$\begin{aligned}
 \text{Volume/acre} &= \frac{30 + 40 + 50 + 5 + 10}{5} \\
 &= \frac{135}{5} \\
 &= 27 \text{ loads/acre}
 \end{aligned}$$

$$\begin{aligned}
 \text{Total volume on the area} &= 27 \text{ loads/acre} \times 5,000 \text{ acres} \\
 &= 135,000 \text{ loads}
 \end{aligned}$$

If the area is divided into strata A and B the total volume is calculated as follows.

Area Stratified

$$\begin{aligned} \text{Volume/acre of strata A} &= \frac{30 + 40 + 50}{3} \\ &= 40 \text{ loads/acre} \\ \text{Total volume on strata A} &= 40 \text{ loads/acre} \times 1,000 \text{ acres} \\ &= 40,000 \text{ loads} \\ \text{Volume/acre of strata B} &= \frac{5 + 10}{2} \\ &= 7.5 \text{ loads/acre} \\ \text{Total volume on strata B} &= 7.5 \text{ loads/acre} \times 4,000 \text{ acres} \\ &= 30,000 \text{ loads} \\ \text{Total volume on the area} &= \text{strata A} + \text{strata B} \\ &= 40,000 \text{ loads} + 30,000 \text{ loads} \\ &= 70,000 \text{ loads} \end{aligned}$$

The total volume estimate, if the area is stratified is in this case approximately half the estimated volume of the area calculated without stratification. Since the volume obtained after the area has been stratified is more accurate this technique improves considerably the accuracy of the estimate of total volume.

(ii) Planning Trade Cutting Operations

The approximate volume per acre can be obtained from the forest type if the area is known. ~~Firedamaged areas, dieback areas and areas likely to contain poles~~ can also be seen.

(iii) Fire Control Planning

Sapling areas requiring protection can be seen on an A.P.I. map. The total stand density will give an indication of the rate of litter accumulation.

(iv) Planning for Silvicultural Treatment

Areas suitable for thinning may be indicated on the map.

Aerial Photographic Interpretation of Pine Stands

Since records are kept in the plantation register of the species, strain and the year of planting, there is no need to determine this from aerial photographs. They are used, however, to define areas of different site quality. Pine plantations are classified into four strata on this basis.

1. High volume per acre stands (Dense crown cover)
2. Moderate volume per acre stands
3. Low volume per acre stands
4. Non forest (No crown cover)

The advantage of classifying the forest into strata to obtain a better estimate of the total volume on assessment have already been discussed. This classification of pine stands is also useful for management purposes, as areas to be thinned or high pruned can be easily defined.

ASSESSMENT OF THE HARDWOOD FOREST

Assessment of the hardwood forest is carried out by the working plans section. The information which is collected and processed is useful for a wide variety of purposes in the day to day management of the forest. To be able to use this information it is important to understand the method by which it is collected.

1. The forest is divided into blocks (Example : Alco Block, Park Block) and each block, and permit area within a block is assessed separately.
2. The block is stratified into the following seven classes in the southern forest region.

Virgin or cutover jarrah, jarrah/marri, marri/jarrah
karri, karri/marri
marri, marri/karri

Non forest

Fig. 9 :

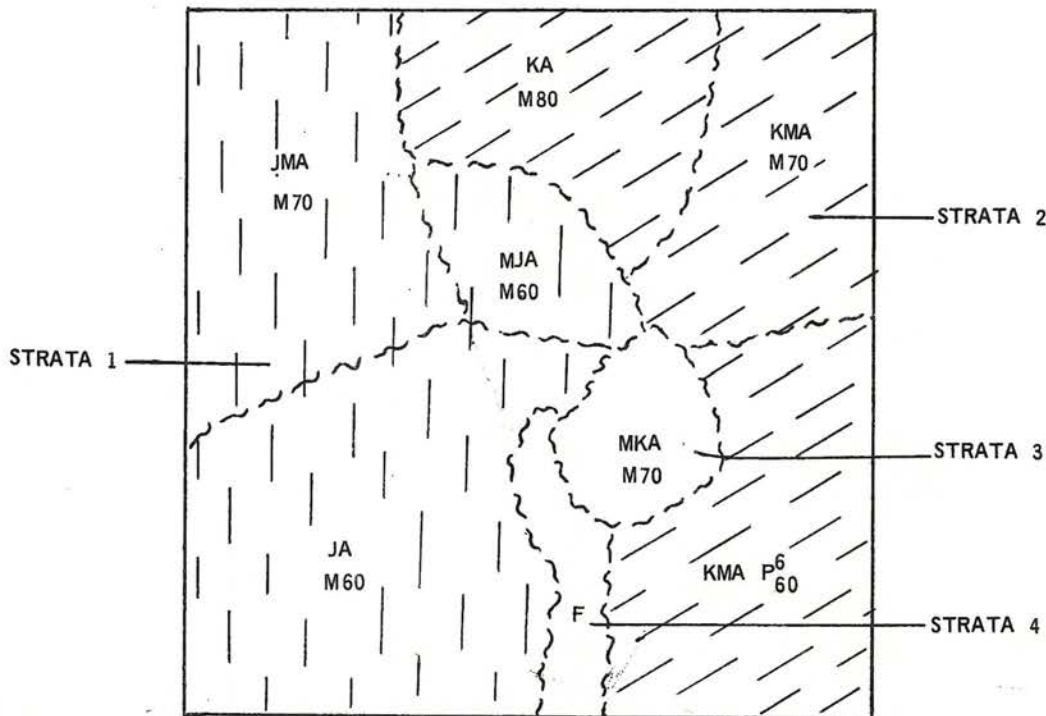

In the northern forest region the strata are based on dieback types (type 1, 2, 3, and non forest).

3. An estimate is made of the number of plots to be placed in each strata to obtain a reasonably reliable figure of the volume that the strata contains. The number of plots placed in each strata will depend upon its size and the variation of the forest within it. The variation can be obtained from past assessment or from an estimate in unknown areas.
4. The centre of the plots, which are usually strips twenty chains long by one chain wide, are selected randomly. The position of the plot is then drawn through the centre point on a forty chain to the inch A.P.I. plan and they are orient-ed to run across the contours, so that a variety of forest types,

from ridge top to valley bottom is assessed. Plots which are located closer than approximately two chain from a strata boundary are discarded, so that forest is not assessed which is a transitional area from one forest type to another.

5. The position of the plots is located in the field by surveying from the nearest known point; for example a reference tree or road junction.
6. The following data is recorded on each two acre plot.
 - (i) Each tree over 60" gbh is assessed and the species, girth breast height, volume in loads and merchantability class is recorded. The merchantability classes indicate trees to be retained as crop trees, trees to be removed under tree marking, unmerchantable trees and dead trees.
 - (ii) On the first two chain of the assessment plot (0.2 acres) additional information is recorded.
 - (a) The species, girth breast height, volume in cubic feet and merchantability class of trees 36"-60".
 - (b) The number and species of trees 12"-24" and 24"-36" gbh.

The height and girth breast height of a co-dominant tree in each plot is recorded. The assessor describes the extent of fire damage and prescribes how the stand should be treated silviculturally.

Fig. 10 :

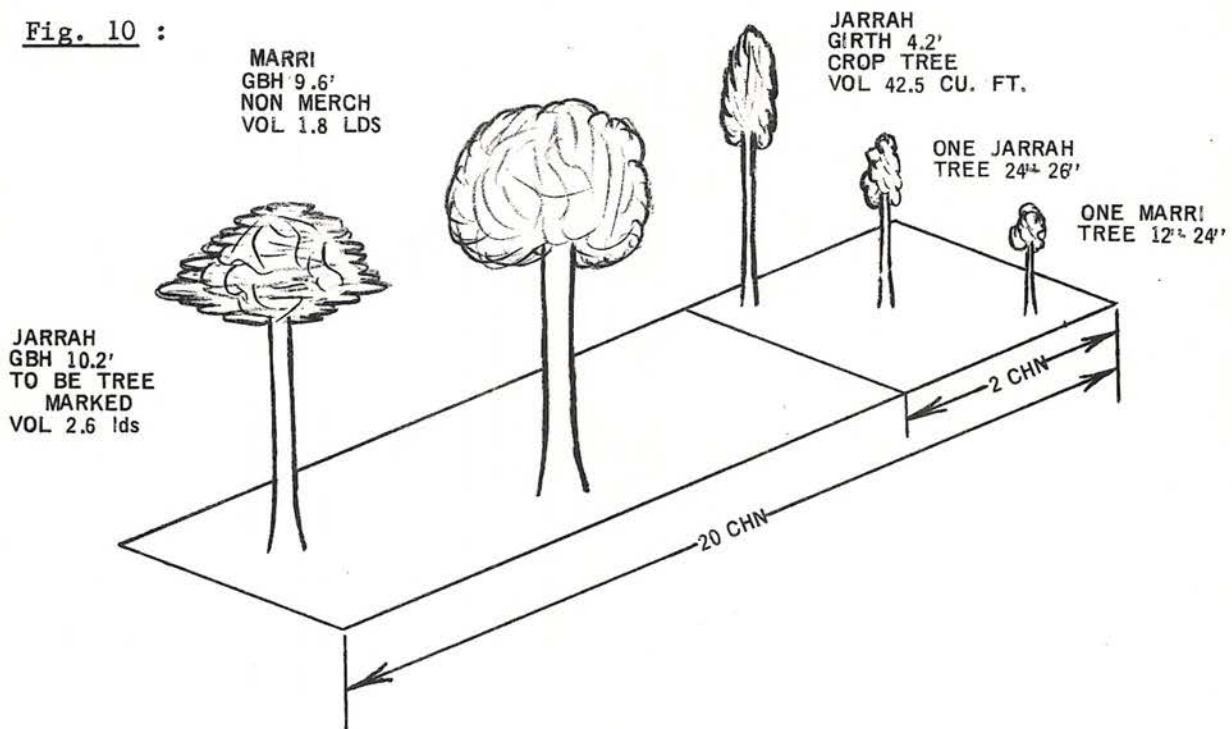

Processing Data from the Assessment of Hardwood Forest

The assessment data is processed by a computer, which prints a summary sheet for each strata in the block. These sheets contain a mass of data. Useful information available for the day to day management of the forest is listed below. For each strata (example cutover J, JM, MJ; virgin J, JM, MJ; cutover K, KM etc.) the following figures can be obtained.

- (i) The average volume per acre of each species in the area, in each merchantability class (Crop trees trees to be removed and unmarketable trees).
- (ii) The average volume per acre of trees in each size class; 12-36", 36-60" and greater than 60".
- (iii) Statistical figures which indicate the reliability of the estimate of the total loads per acre.
- (iv) The volume, basal area and stems per acre of each species in one foot girth classes (example 1-2', 2-3', 3-4', up to 15').
- (v) A summary of the total volume of each species in each merchantability class in the strata.

This information for each strata in the block is totalled and a summary sheet of the data for the whole block, and for each permit area in the block is printed.

The Use of Information from the Assessment of Hardwood Forest

Information from the assessment of the hardwood forest, for example the number of loads per acre of each species and its merchantability, is used to plan the areas to be cutover by mills each year. Some examples of information which can be used to plan the management of the forest are, the amount of small sized material on an area, areas of fire damaged timber which should be cut immediately, and the volume of marri suitable for sawmilling.

From the information collected for several blocks, the total volume and size class of timber on each permit can be calculated. The amount that should be cut each year to obtain a sustained yield can then be estimated. This serves as a basis to setting the permissible intake of a mill.

ASSESSMENT OF PINE PLANTATIONS

Because of the high value per acre of pine plantations, they are assessed more accurately than hardwood forest, and the procedure for establishing plots is different. As mentioned previously, each planting year is classified for assessment purposes into three strata from aerial photographs.

The centre point of plots are positioned randomly on a map by the use of random number tables. This centre point is established in the field by survey, usually from a feature such as a compartment corner. At this point a basal area prism, which was described in Measurement Section I is used to determine which trees are included in the plot and those which are not. Because the diameter of the tree will determine how far from the centre peg a tree can be to be counted as "in", the radius of these plots will vary with the diameter of the trees. They are therefore called variable radius plots.

Fig. 11 :

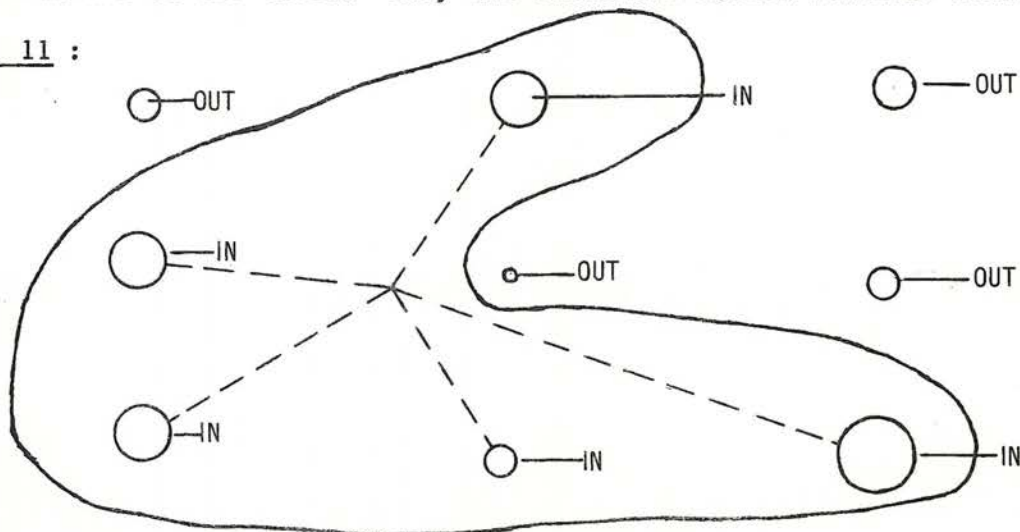

Measurements of total height, d.b.h.o.b. and four bark thickness measurements are taken for each tree in the plot, and its merchantability and potential as a final crop tree is recorded. Most of the plots established are temporary plots; that is, their exact location in the field is not recorded. Some plots, however, are established permanently by placing an aluminium tube in the ground at the plot centre point and nailing identification tags to the base of each tree. These plots will supply growth data for the plantation when measured periodically.

The data is processed by computer and presented in a form which is useful for management purposes; for example, the volume expected from thinning the plantation.

RECORDS OF TRADE OPERATIONS

To estimate the future life of a permit, the rate at which the forest is being cut over must be known. Where tree marking is carried out it is important to compare the volume which working plans assessors estimate should be removed to the volume that is actually removed under tree marking. This information is obtained by a quarterly assessment of cutover bush, and is sent to working plans and head office.

The area cut over each quarter is determined by a compass and pace survey of the boundary, which is plotted on the divisional progress plan. Eight acres are assessed by running eighty chains of assessment line, and measuring all trees half a chain either side of this line. Although it is stated in the Forester's Manual that all girths may be estimated with occasional checks, it takes little extra time to measure the girth of each tree; thus increasing the accuracy of the assessment.

The field book 1/1954 can be used for this assessment by drawing additional columns and inserting headings to record all the classes of marketable, unmarketable and removed timber required. For convenience, however, the form F.D.423 can be used in the field to book this information, since it is ruled correctly. A summary of this field sheet and not the field sheet itself, however, should be sent to the working plans office and head office. For details of the method of carrying out quarterly assessment see the Forester's Manual, Pamphlet No. 6, Sections 35-46.

The following information is then sent to the working plans office and head office.

A Record of the Quarterly Assessment is summarised on form F.D.423 (see Fig. 12), and one copy is sent to both the working plans office and head office. This form provides the working plans section with information on percentage of the forest removed under tree marking.

The Area Cut Over on Sawmilling Permits and Head Office Licences is recorded on form F.D.512 (see Fig. 13), and is sent to both the working plans office and head office. The area cut over in each forest type (J, K, W, etc.) and the tenure of the land from which the timber was removed is recorded.

The Volume Removed on all Local Forest Produce Licences within the division is recorded on form F.D.502 (see Fig. 14) and is sent to both the working plans office and head office. The class of logs and the source of logs is also stated.

These two forms, F.D.512 and 502 are sent to head office to provide information for the compilation of the detailed annual report.

Form 390B is now no longer used since its place has been taken by the two forms, F.D.512 and 502.

The Area and Map Reference of Each Piece of Cut Over Bush for each sawmilling permit or forest produce licence is forwarded to the working plans office only, on form F.D.517 (see Fig. 15). The divisional progress plans are periodically sent to the working plans office on request (usually every six months) to transfer the areas cut over onto their plans. The areas on the progress plans are checked with areas entered on form F.D.517, and if they differ by more than five percent, form F.D.516 is sent by the working plans office to the division requesting that the area be rechecked.

The use of the following three forms 512, 502 and 517 is at present under review (January 1970) and it is possible that they will soon be combined so that the information they contain will be submitted on one new form.

Figure 16 summarises the forms which must be completed and where they are to be sent.

Fig. 16 :

FLOW CHART OF FORMS AND INFORMATION REGARDING TRADE OPERATIONS AND CUT OVER BUSH.

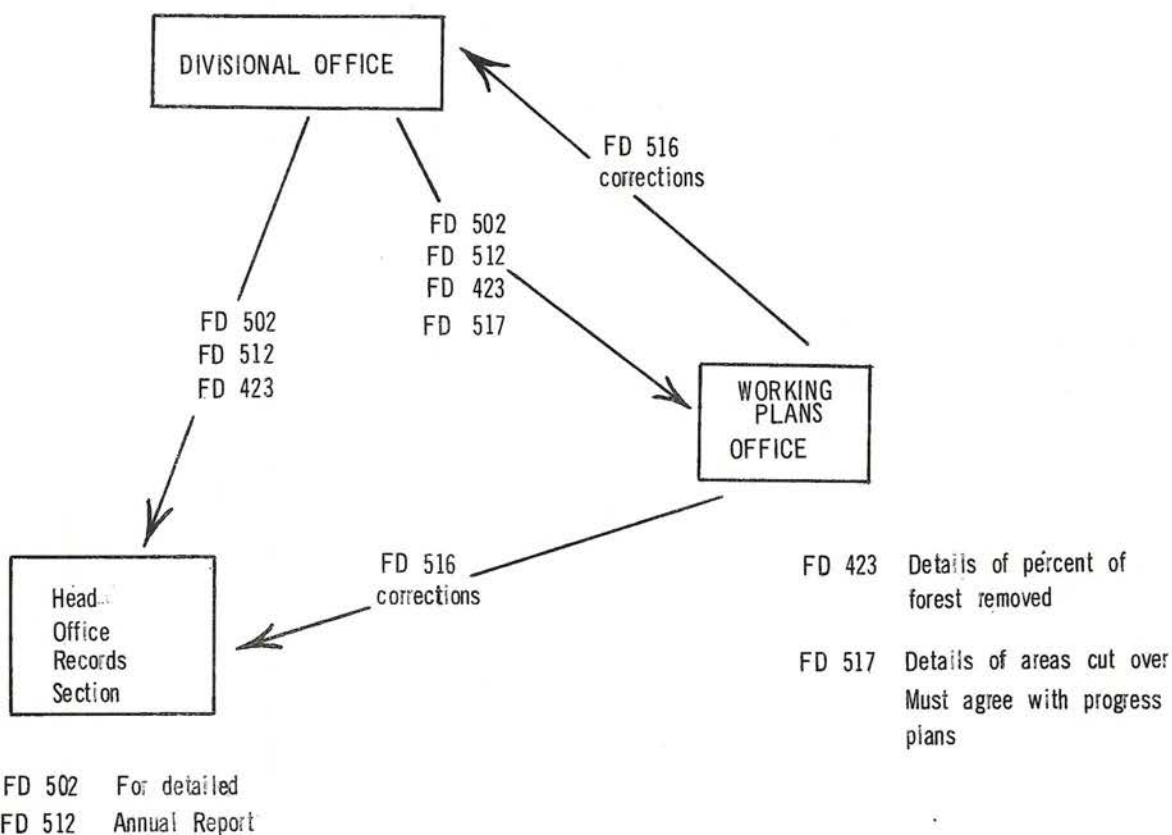

Remember that none of the returns discussed in this section record the actual volume of timber cut by the mill. This is obtained from the mill log book. The total volume of logs received at the landing and the timber which is cut from them is summarised on form F.D.182, Summary of Sawmilling Operations, which is compiled monthly. This form will be discussed in a later section.

D.F.O.'s QUARTERLY SUMMARY OF CUT-OVER BUSH

DIVISIONDwellingup.....

QUARTER ENDED9/69.....

Start 12 chns. NE of Ref. tree CP 9 ⁸⁸ 120'T

LOADS PER ACRE

S.I.P.	Acs. ASSD	SPP	LOADS MARKETABLE						LOADS REMOVED			FNT (see Note 1)	% Removed (see Note 2)	LOADS MARKETABLE			TOTAL MARRI		Poles Piles No.	Re-marks	
			60" - 72" C1	72" - 90" B1	72" - 90" B2	Over 90/108 A1 A2 A3			Over 90/108 R1	Under 90/108 R2	Old Cut'g R			60-72	72-90 /108	Over 90/108	Pot Mkt	Un Mkt			
540	1	J	0.8		1.5	2.5	2.5				5.00	19.00			0.50			7.0	8.5		
"	1	J	2.0							7.8	5.50	5.00	5.00		1.00						
"	1	J	0.8		0.8					15.5	5.50		1.50								
"	1	J	0.8	1.5+	2.0		5.0			8.0	5.00	3.50	11.50								
"	1	J	0.5			1.0		0.5	6.0*	8.0	2.00	14.50									
6' T from Ref. tree CP																					
1500	1	J		0.75	3.0	*5.3			*7.0	13.5	3.50	9.00									
	1	J			3.7	*3.0				7.0	1.00	14.00									
	1	J			2.0					13.0	7.25	1.50	4.50								0.5
TOTAL	8		4.90	2.25	13.0	11.80	7.5	0.50		72.80	34.75	66.50	22.50	67.0	1.50			7.0	9.0		

M.I.T.'s to be indicated by asterisk under columns C2 B2 A3.

Note : 1. F.N.T. : "Felled Not Taken" - trees marked for removal but proved to be unmarketable when felled.

2. % Removed : % Removed - Volume of R1 and R2 + Total Volume of Cols. 4-12 x 100.

FOR TREE CLASSIFICATION SEE FORESTERS' MANUAL AND FIELD BOOK TYPE 1/1954

Details of Co-dominant trees not required.

Dwellingup DIVISION/DISTRICT SUMMARY OF AREAS CUT OVER FOR QUARTER ENDED 9/69

All permits and Head Office Licences in the Division must be listed with nil returns if necessary

S.M.P.	TENURE OF AREA CUT OVER	AREA CUT OVER			AREAS CUT OVER BY SPECIES			REMARKS
		Maiden	Old Bush	Jarrah (acs.)	Karri (acs.)	Wandoo (acs.)	O. Species (acs.)	
1319 FPL 1083	State Forest Timber Reserves Other C.L. P.D.T.R. (Est.) P.P. Estimated		✓ ✓	687 124				Reserve 1158
F.D. Hill	State Forest Other C.L. Timber Reserves P.P.T.R. (Est.) P.P. Estimated		✓	166				
1540PTI 1540PTII	State Forest Other C.L. Timber Reserves P.P.T.R. (Est.) P.P. Estimated			819				Harvey to Supply Area

Dwellingup

..... DIVISION

APPENDIX

PERIOD ENDED 9/69

SUMMARY OF LOGS REMOVED UNDER
LOCAL LICENCE AND LOG SALE
AGREEMENTS

(for Head Office licences and permits, use F.D.512)

LICENCE NO.	NAME OF OPERATOR	CLASS OF LOGS (Cross out those not applicable)	SOURCE OF LOGS (Major permit, State Forest or Clean Cut)	VOLUME REMOVED (from Log Book)
FPL	B. Greenfield	M.N.T. Dieback Other Salvage T.M. Clean Cut	STATE FOREST Salvage areas cut by H.S.B.S. 9/68	507
FPL 9721	A. Klarich	M.N.T. Dieback Other Salvage T.M. Clean Cut	STATE FOREST	669
FPL 11021	R. K. Taylor	M.N.T. Dieback Other Salvage T.M. Clean Cut	STATE FOREST Salvage Murray Plantation area cut by H.S.B.S. 3/69	839

APPENDIX I

RANDOM NUMBERS

51772	74640	42331	29044	46621
24033	23491	83587	06568	21960
45939	60173	52078	25424	11645
30586	02133	75797	45406	31041
03585	79353	81938	82322	96799
64937	03355	95863	20790	65304
15630	64759	51135	98527	62586
09448	56301	57683	30277	94623
21631	91157	16251	54754	44290
91097	17480	29414	06829	87843
50532	25496	95652	42457	73547
07136	40876	79971	54195	25708
27989	64728	10744	08396	56242
85184	73949	36601	46253	00477
54398	21154	97810	36764	32869
65544	34371	09591	07839	58892
08263	65952	85762	64236	39238
39817	67906	48236	16057	81812
62257	04077	79443	95203	02479
53998	90276	62545	21944	16530

POINTS FOR DISCUSSION

The following points are suggested for you to discuss with other officers, especially your D.F.O. You may be able to think of others which you should also talk over with other people.

1. Would it still be acceptable if, when two plots are randomly located, part of one is included in another?
2. Why can't as many statistical calculations be done with data collected by systematic sampling, and what information cannot be obtained because of this?
3. What are some of the cases of personal bias?
4. How important is it to accurately find the position in the field of a plot which has been randomly located on a map?
5. Could you see a three dimensional view by looking at one photo through a stereoscope? Why?
6. How accurate are the forest type boundaries on A.P.I. maps?
7. At present the forests of Western Australia are assessed by measuring sample plots. Are there any other ways of assessing the forest which could be used in the future?
8. What are some of the uses you could make of information collected by the workings plans section?
9. Are we cutting state forest at a rate which will give us a sustained yield?
10. In a 10,000 acre block, plots were assessed and the total amount of timber on them was 5,000 loads. However, the assessor made an error by including two trees totalling ten loads in the plot which were in fact outside. The calculation of the mean loads per acre in the block was therefore incorrect. How many loads out will be the estimate of the total volume on this block because of this error?

References

1. Carron L. T.
An Outline of Forest Measurement with Special Reference to Australia.
2. The Forester's Manual
(for the section on Quarterly Assessment and Records of Trade Operations)

TEST QUESTIONS

Answer the following questions and complete the exercises, and send them to the Training Officer, Dwellingup.

The marks allocated indicate the relative importance of the questions, and you should divide your time accordingly.

These questions should not take you more than 1½ hours to complete.

1.
 - (a) You are required to assess the availability of eucalypt poles in an area of high quality jarrah forest. What aids are available for this assessment?
 - (b) What information is shown on A.P.I. maps? How can these maps assist you in the general running of your district?
 - (c) Why is quarterly assessment carried out?
 - (d) Describe the forest type indicated by the following symbols.
30
(i) JMB + P70 SFD
(ii) KA M 60 V

(48 marks)

2. Map A attached is a plan of an area of forest containing a considerable number of both jarrah and karri poles. It has been decided to assess the number of poles in the area by placing ten chain by one chain strip plots in the area. Assume that the forest types shown on the map are fairly accurate.

Now draw the position of these plots on the map and describe how you would select them. Discuss any of the points which you considered in deciding how and where to place these plots, for example :

- (a) How many plots would you measure?
- (b) Which forest types would you place these plots in?
- (c) Would you position the plots systematically or randomly? Explain the reasons for your choice.
- (d) If you positioned the plots systematically explain in detail how you did this.
- (e) If you positioned them randomly draw a grid over the map, describe how you read the random number table and how you oriented the plot on the point selected.
- (f) Would you divide the forest types into strata? If so, why, and how many strata would you use, how many plots would you place in each strata and which forest types would you place in each strata?
- (g) What information would you record in your assessment of each plot? (Assume you are looking for SEC and PMG poles)
- (h) How would you locate these plots in the field?
- (i) How would you use the information from the measurement of these plots to tell you how many poles were in the area?

(30 marks)

3. Map B shows areas in a division which were out in the last quarter of 1969 by sawmills and salvage operators. From this information prepare the forms F.D.502, 512 and 517 attached and send them to the Training Officer.

In addition :

- (a) Although you are not familiar with the area draw in the approximate position of the quarterly assessment lines which you would run.
- (b) State how many copies you would prepare of each form and where you would send them.
- (c) State why each form is sent to the various offices.
- (d) Describe how the local working plans office records areas which are cut over.

(22 marks)

MAP A

SCALE 40 CHAINS TO AN INCH

62

63

64

65

66

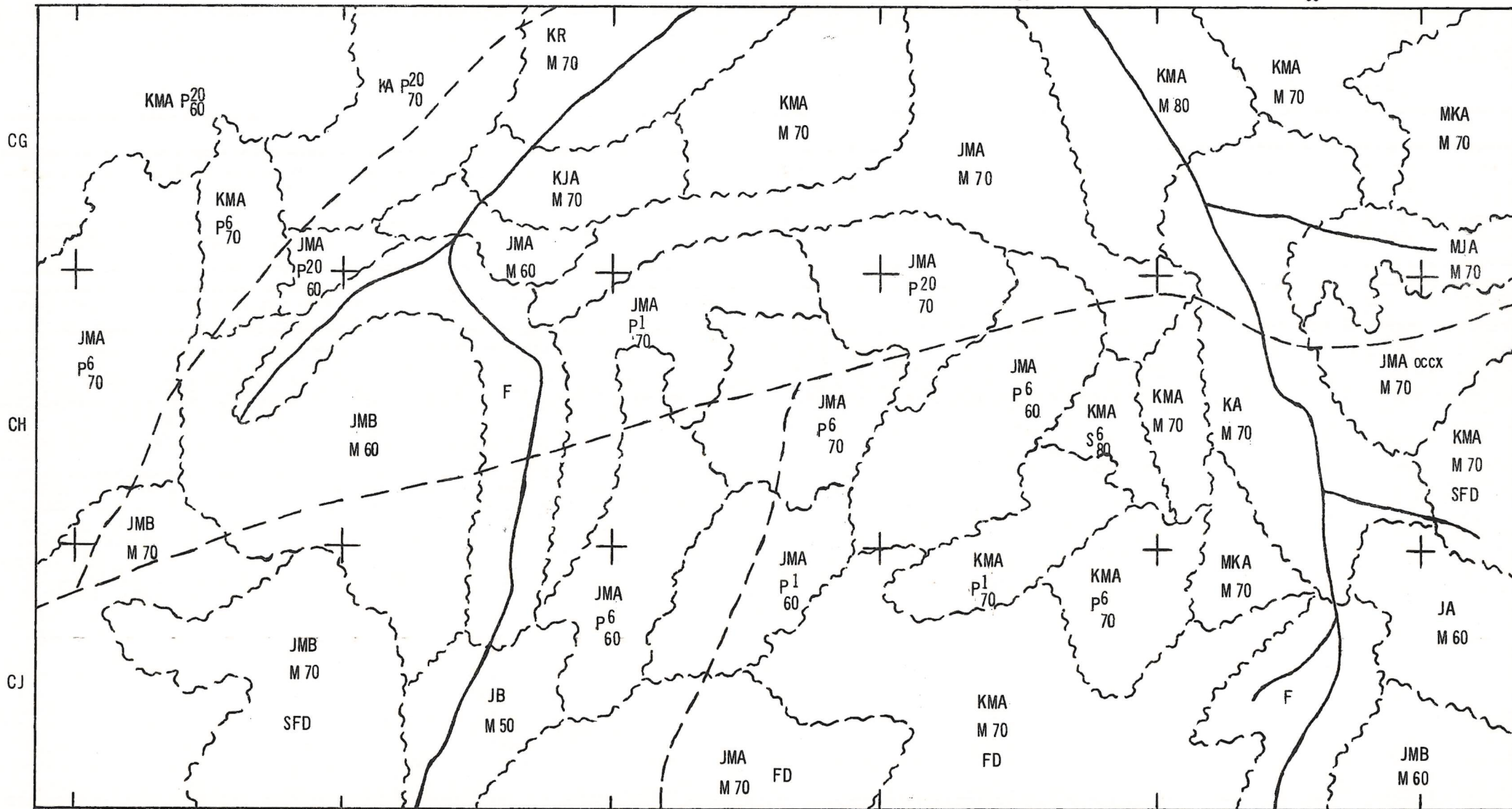

MAP B

SCALE 40 CHAINS TO AN INCH

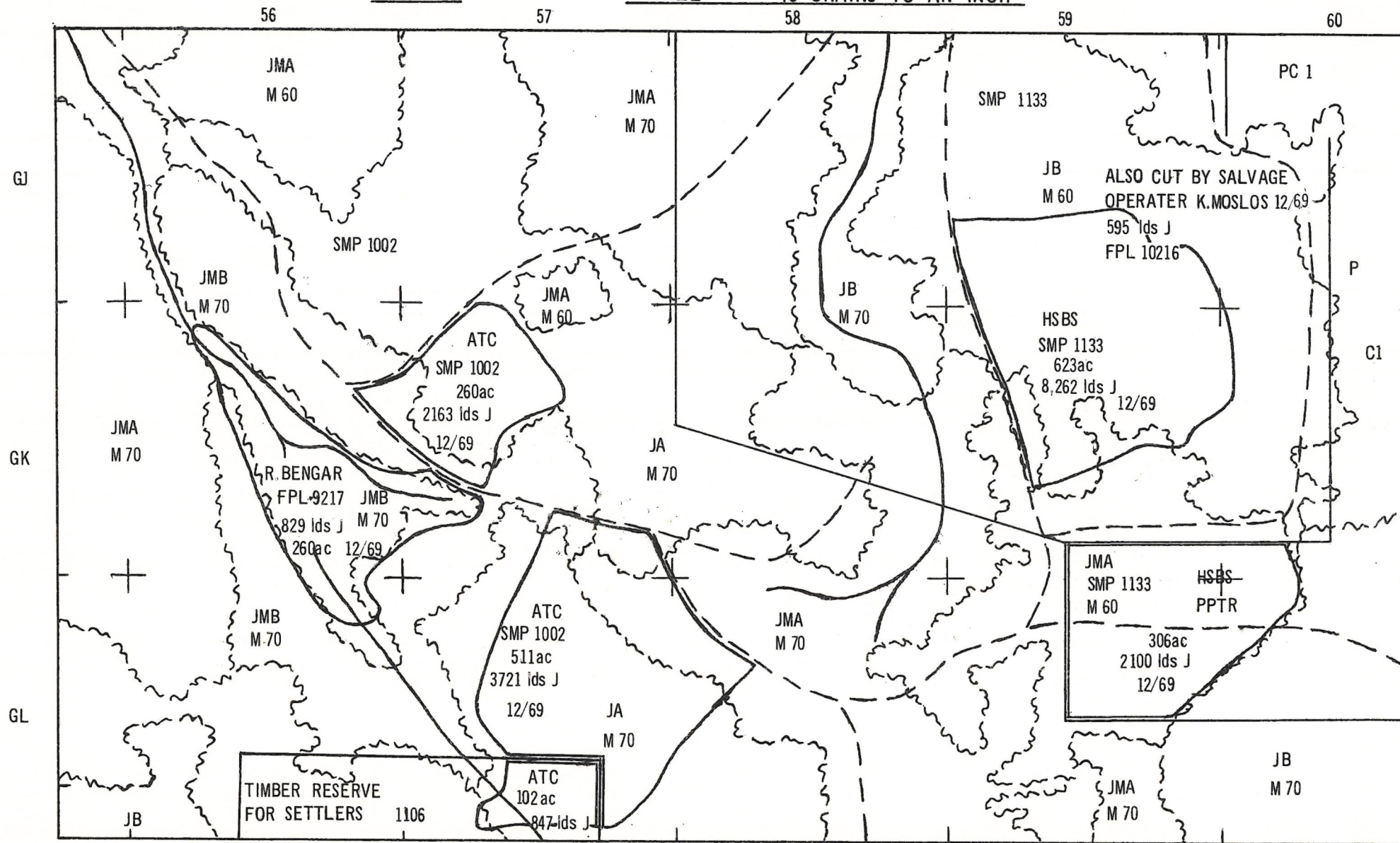

D.F.O.'s QUARTERLY SUMMARY OF
CUT-OVER BUSH

DIVISION

QUARTER ENDED

LOADS PER ACRE

B.H.P.	AC8 A88D	SWP	LOADS MARKETABLE			LOADS REMOVED				FNT (See Note 1)	% Removed	LOADS MARKETABLE			TOTAL MARRI		Poles Piles No.	Re- marks
			60"-72" C1 C2	72"-90" B1 B2	Over 90/108 A1 A2 A3	Over 90/ 108 R1	Under 90/ 108 R2	Old Cut'g R	60-72			72-90 /108	Over 90/ 108	Pot Mkt	Un Mkt			

N.N.T.'s to be indicated by asterisk under columns C2 B2 A3.

Notes : 1. F.N.T. "Felled Not Taken" = trees marked for removal but proved to be unmarketable when felled.

2. % Removed : % Removed = Volume of R1 and R2 + Total Volume of Cols. 4-12 x 100.

APPENDIX

..... DIVISION

Period Ended

SUMMARY OF LOGS REMOVED UNDER LOCAL LICENCE
AND LOG SALE AGREEMENTS

(For Head Office Licences and Permits, use F.D.512)

LICENCE NO.	NAME OF OPERATOR	CLASS OF LOGS (Cross out those not applicable)	SOURCE OF LOGS (Major permit, State Forest or Clean Out)	VOLUME REMOVED (from log book)
		M.N.T. Dieback Other Salvage T.M. Clean Out		
		M.N.T. Dieback Other Salvage T.N. Clean Out		
		M.N.T. Dieback Other Salvage T.M. Clean Out		

..... DIVISION/DISTRICT SUMMARY OF AREAS CUT OVER FOR QUARTER ENDED

All permits and Head Office Licences in the Division must be listed with nil returns if necessary.

SMP	TENURE OF AREA	AREA CUT OVER		AREAS CUT OVER BY SPECIES				REMARKS
	CUT OVER	Maiden	Old Bush	Jarrah (acs.)	Karri (acs.)	Wandoo (acs.)	O. Species (acs.)	Please quote P.P., Location No. and P.P.T.R.
	State Forest Timber Reserves Other C.L. P.P.T.R. (est.) P.P. Estimated							
	State Forest Timber Reserves Other C.L. P.P.T.R. (est.) P.P. Estimated							
	State Forest Timber Reserves Other C.L. P.P.T.R. (est.) P.P. Estimated							

PROGRESS PLANS CHECK BY _____ W.P.O.

DIVISION

QUARTER

Divisional Use. (Sent to W.P.O. with 390B's)						W.P.O. Use			
SMP or Licence Number	Tenure	Total Area on 390B (now 512)	Area on Plan	Species and Loads	Map and Square Ref.	Areas Chckd.	Inform. Trans. to :		
							HO	WOP	CH