



YULE RIVER WATER RESERVE WATER SOURCE PROTECTION PLAN

Port Hedland Regional Water Supply



WATER RESOURCE PROTECTION SERIES

WATER AND RIVERS COMMISSION REPORT WRP 30

2000



WATER AND RIVERS
COMMISSION

WATER AND RIVERS COMMISSION

HYATT CENTRE

3 PLAIN STREET

EAST PERTH

WESTERN AUSTRALIA 6004

TELEPHONE (08) 9278 0300

FACSIMILE (08) 9278 0301

WEBSITE: <http://www.wrc.wa.gov.au>

We welcome your feedback

A publication feedback form

can be found at the back of this publication,

or online at <http://www.wrc.wa.gov.au/public/feedback/>

(Cover Photograph: Cattle grazing on Mundabullanga pastoral lease)



YULE RIVER WATER RESERVE WATER SOURCE PROTECTION PLAN

Port Hedland Regional Water Supply

Water and Rivers Commission
Policy and Planning Division

WATER AND RIVERS COMMISSION
WATER RESOURCE PROTECTION SERIES
REPORT NO WRP 30
2000



Acknowledgments

Contribution	Personnel	Title	Organisation
Program Direction	David Boyd	Manager, Water Quality Protection	Water and Rivers Commission
Supervision	Ross Sheridan	Program Manager, Protection Planning	Water and Rivers Commission
Hydrogeology / Hydrology	Angus Davidson	Program Manager, Groundwater Resources Assessment	Water and Rivers Commission
Report Preparation	Rachael Miller	Environmental Officer	Water and Rivers Commission
	Rueben Taylor	Water Resources Planner	Water and Rivers Commission
	Dot Colman	Water Resources Officer	Water and Rivers Commission
Drafting	Nigel Atkinson	Mapping Consultant	McErry Digital Mapping

For more information contact:

Program Manager, Protection Planning
Water Quality Protection Branch
Water and Rivers Commission
3 Plain Street
EAST PERTH WA 6004

Telephone: (08) 9278 0300
Facsimile: (08) 9278 0585

Reference Details

The recommended reference for this publication is:
Water and Rivers Commission 2000, *Yule River Water Reserve Water Source Protection Plan: Port Hedland Regional Water Supply*, Water and Rivers Commission, Water Resource Protection Series No WRP 30.

ISBN 0-7309-7382-4
ISSN 1326-7442

*Printed on recycled stock
September, 2000*



Foreword

Water Source Protection Plans

Water Source Protection Plans establish the level of protection required within Water Reserves. The plans identify sources of contamination that should be investigated and set out programs for management of the resource. Water Source Protection Plans are developed in consultation with affected landowners and industry groups and relevant Government agencies.

Proclaiming Water Reserves under the *Country Areas Water Supply Act (1947)* protects the quality of water sources in country Western Australia. The Act's by-laws enable the Water and Rivers Commission to control potentially polluting activities, to regulate land use, inspect premises and to take steps to prevent or clean up pollution.

The Water and Rivers Commission aims to work pro-actively with planning agencies to incorporate water protection in the land planning process. Decisions on land use zoning and subdivision applications have a significant impact on the protection of water sources. The Commission supports the amendment of Town Planning Schemes and Development Strategies that reflect land use compatible with Water Source Protection Plans.

This Water Source Protection Plan provides a basis for establishing compatible land uses within the Water Reserve at Yule River and is a mechanism for practical implementation of the Commission's protection strategies. Local government decision-makers, State planning authorities and operational staff are encouraged to recognise this document as a basis for ensuring the long term protection of this groundwater resource for generations to come.

Water quality protection framework

The Water and Rivers Commission is responsible for managing and protecting Western Australia's water

resources. The Commission has developed policies for the protection of public drinking water source areas (PDWSAs) that include three levels of priority classification.

Priority 1 (P1) source protection areas are defined to ensure that there is no degradation of the water source. P1 areas are declared over land where the provision of the highest quality public drinking water is the prime beneficial land use. P1 areas would typically include land under Crown ownership. P1 areas are managed in accordance with the principle of risk avoidance and so land development is generally not permitted.

Priority 2 (P2) source protection areas are defined to ensure that there is no increased risk of pollution to the water source. P2 areas are declared over land where low intensity development (such as rural) already exists. Protection of public water supply sources is a high priority in these areas. P2 areas are managed in accordance with the principle of risk minimisation and so some conditional development is allowed.

Priority 3 (P3) source protection areas are defined to minimise the risk of pollution to the water source. P3 areas are declared over land where water supply sources need to co-exist with other land uses such as residential, commercial and light industrial developments. Protection of P3 areas is achieved through management guidelines rather than restrictions on land use. If the water source does become contaminated, then water may need to be treated or an alternative water source found.

In addition to priority classifications, well-head protection zones are defined to protect the water source from contamination in the immediate vicinity of production wells and reservoirs. Well-head protection zones are usually circular, with a radius of 500 metres in P1 areas and 300 metres in P2 and P3 areas. These zones do not extend outside water reserves. Special conditions apply within these zones.



Contents

Summary	1	Implementation strategy	13
1. Introduction	2	References	15
2. Climate	2	Glossary	16
3. Physiography	2		
4. Hydrogeology	5	Appendices	
4.1 Water quality	5	Appendix 1: Land use compatibility in Public Drinking Water Source Areas	17
4.2 Water treatment	5	Appendix 2: Above ground chemical storage tanks in Public Drinking Water Source Areas	26
5. Existing and proposed land use	5	Appendix 3: Plates of land use within the Yule River Water Reserve	31
6. Proposed proclaimed area	5		
6.1. Wellhead protection zones	6	Tables	
7. Management of potential water quality risks	6	Table 1. Potential sources of contamination within the Yule River Water Reserve	9
7.1 Protection objectives	6		
7.2 Best management practices	6	Plates	
7.3 Land use planning	6	Plate 1: Cattle gathering around the bore compound.	33
7.4 Emergency response	7		
7.5 Land use, potential water quality risks and recommended strategies	7		
Recommendations	12		



Summary

The Yule River wellfield operated by the Water Corporation is located approximately 45 kilometres west of Port Hedland on the eastern bank of the Yule River. Water is supplied to the town of Port Hedland from bores in the semi-confined deposits of the Yule River.

The source has the potential to be contaminated from the standby diesel fuel storage at each of the bores; from the spillage of fuel or chemicals on the North West Coastal Highway; from the concentration of livestock waste around pools near the bores and from the use of herbicides within the bore compounds.

The existing Water Reserve should be modified to incorporate future extensions of the wellfield and to exclude areas that are not likely to be used for public water supply. The proposed Water Reserve should be classified for Priority 1 source protection.

This plan has undergone extensive consultation during the development process. Discussions were held with key stakeholders prior to the preparation of the draft plan. The draft plan was released for comment to key stakeholders including affected landowners, Water Corporation, Ministry for Planning, Department of Environmental Protection, Department of Land Administration, Department of Conservation and Land Management, Shire of Port Hedland, Pastoralists and Graziers Association and the Conservation Council. Comments received were considered in the preparation of this plan.



1. Introduction

The Yule River wellfield is located approximately 45 kilometres west of Port Hedland on the eastern bank of the Yule River (see **Figure 1**). The Water Corporation operates the scheme in conjunction with the De Grey River wellfield to supply water for the Towns of Port Hedland and South Hedland (Water Corporation, 1996a).

Port Hedland is a major administrative centre for the area and is a deep water port serving the Pilbara iron ore industry. The major industry is the basic processing and export of bulk iron ore, but other industries include solar salt production, service to the local pastoral area and tourism (Water Corporation, 1996a).

The Yule River scheme was commissioned in 1966/67 to supplement supply from the Turner River borefield which had become insufficient to supply the town's requirements. The Turner borefield was later closed in the 1980's due to its high operational costs yet small production volume.

The current licensed allocation for the Yule River wellfield is 5 GL/annum, with an annual average abstraction of 2.6 GL/annum. Recently, the Water Corporation has applied to increase this abstraction to 6.5 GL/annum to meet increased demand from industrial development in the area. The 39 production bores drilled between 1967 and 1973 have been replaced in the existing wellfield with 14 bores drilled in 1996. 7 of these are currently equipped as production bores (1/96, 2/96, 3/96, 11/96, 12/96, 13/96 and 16/96). There is also a network of monitoring bores and stock wells (see **Figure 2**). The depth of screening of the bores is variable between 11 and 49 metres below ground level with the exception of 16/69 which is screened between 48 and 73 metres. The Water Corporation is currently reviewing the Yule River wellfield and may re-drill and re-equip some of the decommissioned wells in the future. The bores pump to the Yule River collector tank before either gravitating or being pumped to South Hedland and then to Port Hedland.

The Yule River wellfield is situated within the Pilbara Groundwater Area, proclaimed under the *Rights in*

Water and Irrigation Act 1914. Under this Act, all groundwater abstraction bores require licensing.

Extension of the wellfield is likely to be in a southerly direction along the banks of the Yule River.

There is the potential for future water supply development in the southern section of the Turner River Water Reserve.

The existing Yule River Water Reserve (see **Figure 3**) was gazetted under the *Country Areas Water Supply Act (1947)* on 18 September 1970 for the purpose of protecting the public water supply source.

2. Climate

The climate of the region is described as semi-arid with an average annual rainfall of 300 mm. Rainfall is irregular with almost all falling between January and March as a result of cyclonic activity. Infrequent and unreliable winter rain also occurs.

3. Physiography

The Yule River Scheme is situated within the Port Hedland coastal plain.

The Port Hedland coastal plain overlies eroded basement rocks and rises gradually from sea level to about 50 metres Australian Height Datum (AHD) (Skidmore, 1996).

The Yule River is the largest and longest river in the Port Hedland Coast Basin. It is ephemeral in nature, indicating the erratic nature of rainfall and flows only after heavy rain.



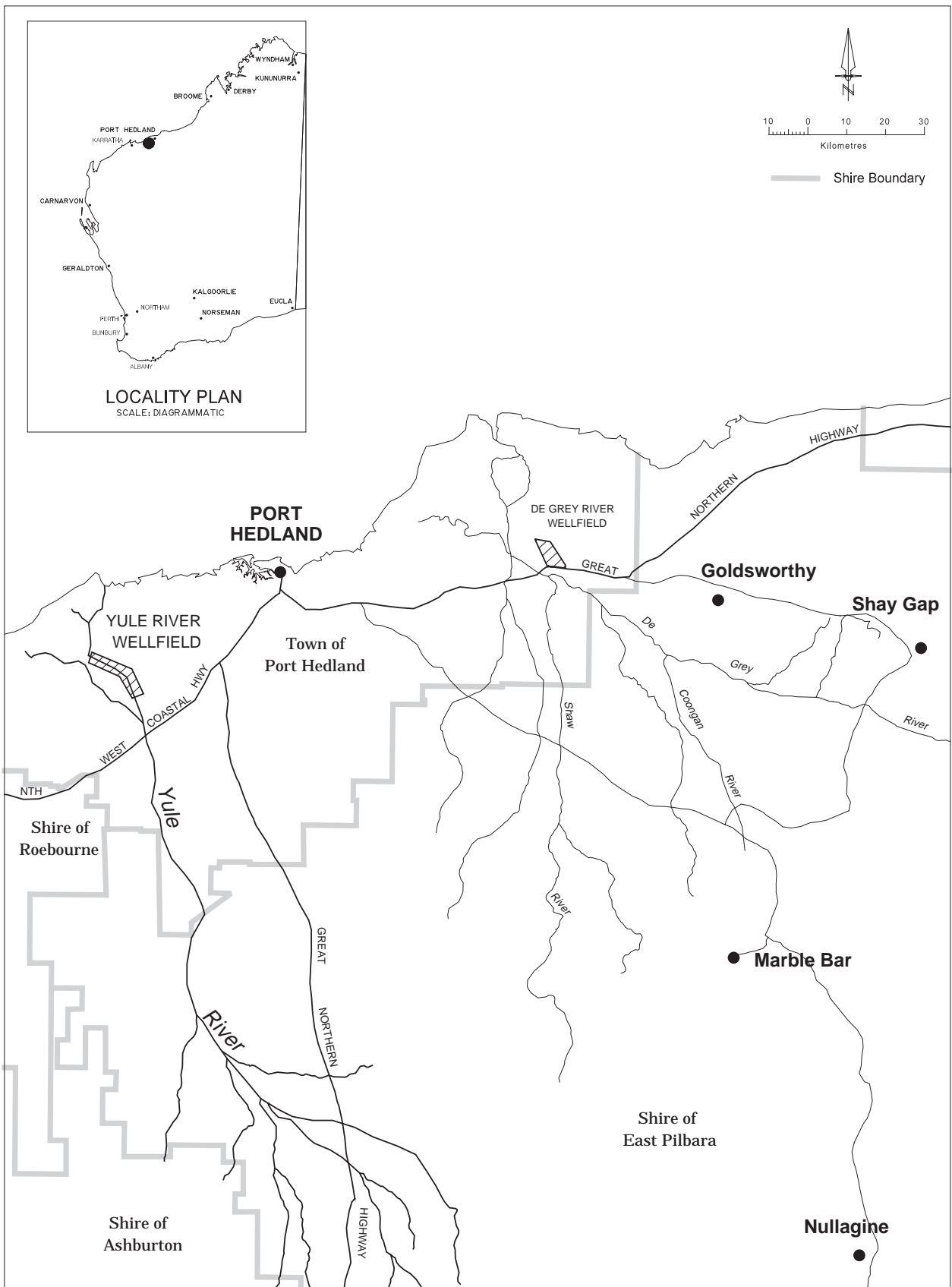

Figure 1. Yule River locality map



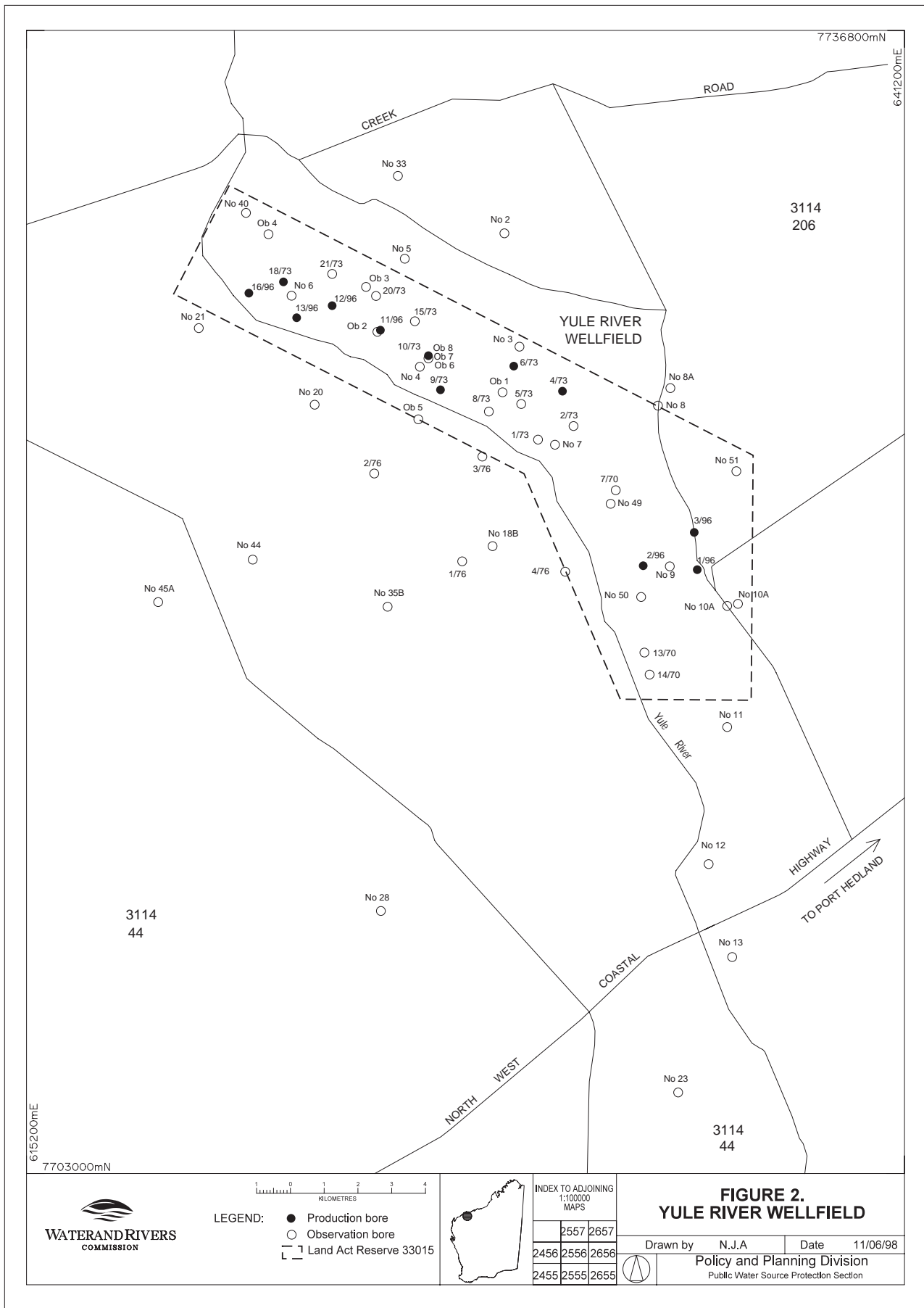

Figure 2. Yule River Wellfield



4. Hydrogeology

The local geology of the Yule River consists of Quaternary alluvial sediments overlying Archaean rocks, including granite, schist and quartzite. The wellfield draws water from discontinuous beds consisting of sand, silt, clay and gravel ranging from 25 to 50 metres in thickness. Calcrete deposits exist throughout the alluvial sediments and have developed either through weathering of the bedrock material, or from the seasonal fluctuation of the water table. The water table in the vicinity of the wellfield lies approximately 4 to 10 metres below the ground surface, although it has met ground surface over parts of the wellfield when the river is in flood. Often, a bed of silty clay is present below the water table, which acts as a semi-confining layer (Davidson, 1976).

Most of the recharge to the alluvial aquifer occurs through the river bed sands when the river is in flood, where river water rapidly infiltrates beneath the river bed and then more slowly flows away from the river (Water Corporation, 1996b). Some direct recharge may occur during high intensity rainfall events. In addition, recharge to the aquifer on the south west side of the river includes groundwater throughflow from the south east. In the vicinity of the wellfield, groundwater flow is away from the riverbed in a north easterly or north westerly direction.

As the aquifer is semi-confined, it is vulnerable to contamination from inappropriate land uses within the recharge area of the wellfield.

4.1 Water quality

Water quality from the Yule River scheme is within National Health & Medical Research Council (1996) guidelines for drinking water quality.

Two diesel spill incidents have occurred in the past in the Yule River wellfield. The first was in May 1989 where approximately 16, 000 litres of diesel was spilt from a bulk storage tank into the surrounding ground. This resulted in the Yule River scheme being shut down for a period of time and the De Grey River Scheme being the sole supply for the Hedland area.

The second incident occurred in May 1994 where approximately 4000 litres of diesel was lost to the ground from the bulk fuel tank at production bore 4/73. The source of the spillage was through a lever actuated scour valve being pushed open by a bovine animal.

The cleanup of both spills involved excavation and removal of the diesel soaked soil and refill with clean compacted earth.

4.2 Water treatment

The water from the wellfield is treated by chlorination at the Yule collector tank prior to supply to the public.

5. Existing and proposed land use

The Mundabullanga pastoral lease lies over the northern portion of the Water Reserve. The lease is predominantly savanna-woodland and is grazed with cattle and some sheep.

Several mining and exploration tenements exist over the current Water Reserve. Exploration activity is focussed on gold and other base metals.

The wellfield is sited in Land Act Reserve 33015 which is vested in the Water Corporation for water supply purposes.

The North West Coastal Highway crosses the south eastern corner of the existing water reserve and is a major transport route used by supply vehicles.

6. Proposed proclaimed area

The existing Water Reserve is shown in **Figure 3**. It is proposed to modify the boundary of the Water Reserve as shown in **Figure 3**.

The modifications to the boundary can be justified as follows:

- The proposed reserve allows for and would protect the key recharge area of the southward extension of the wellfield along the banks of the Yule River;
- The proposed reserve includes the river bed sands of the Yule River which is the key recharge area for the wellfield.



-
- The eastern and western boundaries have been reduced to exclude areas which do not form key recharge areas for the wellfield.

The proposed Yule River Water Reserve should be classified for Priority 1 source protection. This classification is justified for the following reasons:

- The water supply is of strategic importance to the Town of Port Hedland;
- The aquifer is semi-confined and therefore would be susceptible to contamination if intensification of land use was to occur;
- The river bed sands located within the water reserve form the key recharge area for the aquifer system.

6.1. Wellhead protection zones

In addition, wellhead protection zones consisting of a 500 metre radius centred around each production bore should be established (see **Figure 4**).

7. Management of potential water quality risks

7.1 Protection objectives

Priority 1 source protection areas are managed in accordance with the principle of avoiding any risk of contamination.

Yule River Water Reserve is a strategic source for water supply to the town of Port Hedland. Consequently, potential risks posed to water quality have been carefully assessed.

This plan aims to balance water quality protection needs with other land use and social needs as much as possible.

This plan recognises the right of existing approved land uses to continue to operate in the Water Reserve.

The Yule River Water Reserve should be managed to ensure there is minimal risk to water quality. It is considered that an improvement in water quality is achievable through the proposed management strategies.

7.2 Best management practices

The adoption of best management practices for land use activities is encouraged to help protect water quality.

To assist the adoption of sound environmental practices, guidelines for specific industries are being progressively developed in conjunction with other agencies (eg. Agriculture Western Australia and the Department of Environmental Protection) and the relevant peak industry body (eg. WA Pork Producers' Association). Examples include recently released Mining and Mineral Processing, Dairy Guidelines and Draft Viticulture Guidelines. These guidelines incorporate a practical, commonsense approach to environmental management issues, and are aimed at avoiding any unreasonable burden to the industry.

The Commission recommends these guidance documents to landowners as best practice for water quality protection.

7.3 Land use planning

The Commission recognises landowners' legitimate rights to continue to use and develop their land in accordance with the priority classification.

Pastoral and mining exploration activities currently occurring in the Yule River Water Reserve are generally compatible with the Priority 1 classification.

Establishing appropriate protection mechanisms in statutory land use planning processes is necessary to secure the long-term protection of water sources.

It is therefore appropriate that the Yule River Water Reserve and Priority 1 classification be recognised in the Town of Port Hedland Town Planning Scheme.

Priority classifications are not statutory under the *Country Areas Water Supply Act 1947*. They define the level of catchment protection that guides the Commission's response on land development proposals..

This protection plan and subsequent recognition of the Water Reserve and priority classifications in statutory planning strategies will provide certainty for long-term management requirements for the land. These



statutory planning mechanisms will determine future development.

The Water and Rivers Commission's input into the development approval process is through providing advice on the compatibility of land uses with the priority classification. Advice is on a case-by-case basis.

The guidance document *Land Use compatibility in Public Drinking Water Source Areas* (see **Appendix 1**) uses the term "conditional" where the land use can usually be compatible with the objectives of source protection, with the adoption of appropriate management practices. Generally, these are practical steps to protect water resources from potential contaminants and cover issues such as fuel and chemical storage, nutrient application and waste disposal.

7.4 Emergency response

Escape of chemicals during unforeseen incidents and use of chemicals during emergency response can cause groundwater contamination. The Shires of East Pilbara and Port Hedland Local Emergency Management Advisory Committee through the DEMAC Group Emergency Management District should be familiar with the location and purpose of the Yule River Water Reserve. A locality plan should be provided to the Fire and Rescue Services headquarters for the HAZMAT Emergency Advisory Team. The Regional Manager Water Corporation should have an advisory role to any HAZMAT incident in the Yule River Water Reserve.

Personnel who deal with WESTPLAN - HAZMAT incidents within the area should be given ready access to a locality map of the Water Reserve. These personnel should receive training to ensure an understanding of the potential impacts of spills on the groundwater resource.

7.5 Land use, potential water quality risks and recommended strategies

The following table details the existing land uses in the catchment, the potential water quality risks and recommends a strategy to manage the risks.

The recommended strategy aims to secure the water quality of this strategic source for the community in the long term, while minimising the constraints on development opportunities and recognising landholders' rights to continue using their land for lawful purposes.

The responsible agencies and appropriate timelines for implementation of the strategies recommended in the following table are outlined in the Implementation Strategy section of this plan.



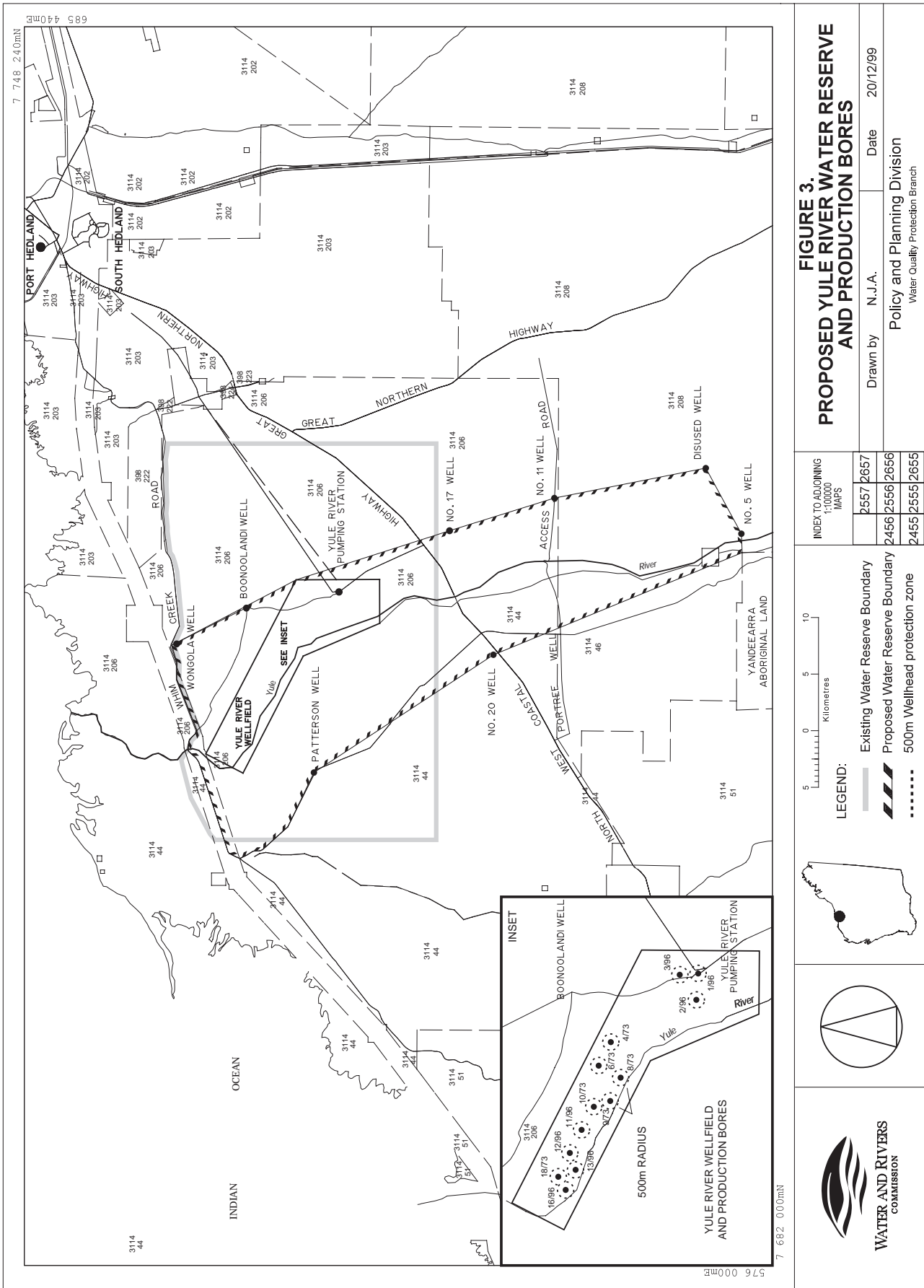

Figure 3. Proposed Yule River Water Reserve and production bores



The following table summarises the potential sources of contamination in the vicinity of the wellfield. The location of each item (where relevant) is shown in **Figure 4**.

Table 1. Potential sources of contamination within the Yule River Water Reserve

Map ref.	Issue	Risks	Threats	Potential Impact	Likelihood	Current Preventative Measures	Suggested Protection Measures
1.	Diesel storage at pumping station	<ul style="list-style-type: none"> Ten 200 L diesel drums for the stand-by generator. (for emergency) Two historic diesel spills in wellfield. 	Groundwater contamination by hydrocarbons and chemicals.	High	Low	<ul style="list-style-type: none"> Bulk fuel tanks emptied and no longer needed. Contaminated soil excavated and removed after spill, effected bores 2/69 and 9/67 sampled weekly and then decommissioned. 	<ul style="list-style-type: none"> Remove unused tanks and bund remaining tanks for backup supply in accordance with Appendix 2.
2.	North West Coastal Highway	<ul style="list-style-type: none"> Vehicles carry contaminating materials. Highway crosses Yule River close to and upstream of the wellfield. Risk of spillage's from accidents. 	Groundwater and surface water contamination by chemicals and hydrocarbons.	High	Low, preventative measures in place	Signage of HAZMAT emergency number to call in case of a spill.	<ul style="list-style-type: none"> Shire of Port Hedland Local Emergency Management Advisory Committee familiar with Water Reserve. Water Reserve locality plan provided to HAZMAT Emergency Advisory Team. The Water Corporation advising HAZMAT Emergency Advisory Team during incidents Personnel dealing with WESTPLAN - HAZMAT incidents given training to understand potential impacts of spills on groundwater resources.

(continued)

Map ref.	Issue	Risks	Threats	Potential Impact	Likelihood	Current Preventative Measures	Suggested Protection Measures
n/a	Pastoral activities the Water Reserve	<ul style="list-style-type: none">• Animal grazing over floodplain of Yule River.• Livestock congregating around watering points and bores.	Microbial contamination of surface and groundwater.	Very Low	Very Low	<ul style="list-style-type: none">• Bore compounds fenced.• Water Corporation has management strategies for bore maintenance.	Maintain fencing around bore compounds.
n/a	Chemical use around bores	Herbicides (Glyphosphate) used around bore compounds to control weeds	Chemical contamination of groundwater.	Low	Low	WC currently laying plastic around all production bores to eliminate the need for chemical use.	na

Recommendations

1. The proposed Yule River Water Reserve should be gazetted under the *Country Areas Water Supply Act 1947*.
2. Consider de-proclamation of the Turner River Water Reserve in consultation with key stakeholders.
3. Planning strategies should incorporate the management principles outlined in the Water and Rivers Commission's *Land use compatibility in Public Drinking Water Source Areas* (see **Appendix 1**) and reflect the Priority 1 classification given to the Water Reserve.
4. All development proposals in the Water Reserve which are likely to impact on water quality should be referred to the Water and Rivers Commission.
5. Signs should be erected along the boundaries of the Water Reserve to define the reserve and promote public awareness of the need to protect water quality.
5. Incidents covered by WESTPLAN – HAZMAT in the Yule River Water Reserve should be addressed through the following measures:
 - The Shire of Port Hedland Local Emergency Management Advisory Committee (through the Karratha Emergency Management District) being familiar with the location and purpose of the Yule River Water Reserve.
 - The locality plan for the Yule River Water Reserve being provided to the Fire and Rescue Services headquarters for the HAZMAT Emergency Advisory Team.
 - The Water Corporation advising the HAZMAT Emergency Advisory Team during incidents in the Yule River Water Reserve.
 - Personnel dealing with WESTPLAN - HAZMAT incidents in the area given ready access to a locality map of the Water Reserve and training to understand the potential impacts of spills on the groundwater resource.
6. A surveillance program should be established to identify any incompatible land uses or potential contaminant threats within the Water Reserve.
7. The contamination risks to aquifers which are recharged by river flows should be investigated further. The investigation should determine appropriate management principals for the water reserve.
8. Any bores re-equipped for production should be fenced off to prevent the intrusion of cattle.
9. Bores should be maintained to prevent leakage to ensure semi-permanent pools which may be used as a livestock drinking source do not develop.
10. Implementation of these recommendations should be reviewed annually after this plan is endorsed. A full review of this protection plan should be undertaken after five years.



Implementation strategy

No	Description	Implemented by	Timing
1.	Gazettal of Water Reserve.	Water and Rivers Commission	2000/2001
2.	Investigate amendment of the boundary of the Turner River Water Reserve in consultation with key stakeholders.	Water and Rivers Commission	ongoing
3.	Incorporation into land planning strategies.	Town of Port Hedland.	ongoing
4.	Referral of development proposals: (i) WRC to provide the Shire of Port Hedland with guidelines for referral of development proposals. (ii) referral of development proposals.	(i) Water and Rivers Commission (ii) Town of Port Hedland, Ministry for Planning, Department of Minerals and Energy and Department of Environmental Protection.	(i) 2000/2001 (ii) ongoing
5.	Erection of signs: (i) development of guidelines for signage. (ii) determine number and location of signs required. (iii) erect signs.	(i) Water and Rivers Commission (ii) Water and Rivers Commission and Water Corporation (iii) Water and Rivers Commission and Water Corporation	(i) 2000/2001 (ii) 2000/2001 (iii) To be determined

(continued)

6.	<p>Incidents covered by WESTPLAN – HAZMAT in the Yule River Water Reserve should be addressed through the following measures:</p> <p>(i) The Shire of Port Hedland Local Emergency Management Advisory Committee (through the Karratha Emergency Management District) being familiar with the location and purpose of the Yule River Water Reserve.</p> <p>(ii) The locality plan for the proposed Yule River Water Reserve being provided to the Fire and Rescue Services headquarters for the HAZMAT Emergency Advisory Team</p> <p>(iii) The Water Corporation advising the HAZMAT Emergency Advisory Team during incidents in the Yule River Water Reserve.</p> <p>(iv) Personnel dealing with WESTPLAN - HAZMAT incidents in the area given ready access to a locality map of the proposed Water Reserve and training to understand the potential impacts of spills on the groundwater resource.</p>	<p>(i) Shire of Port Hedland Local Emergency Management Advisory Committee through WRC (Karratha region)</p> <p>(ii) Water and Rivers Commission (North West Region)</p> <p>(iii) Water Corporation</p> <p>(iv) Shire of Port Hedland Local Emergency Management Advisory Committee</p>	<p>(i) 2000/2001</p> <p>(ii) as soon as possible</p> <p>(iii) Ongoing</p> <p>(iv) Ongoing</p>
7.	<p>Surveillance program:</p> <p>(i) develop guidelines for the surveillance of Water Reserves.</p> <p>(ii) implement the surveillance program.</p>	<p>(i) Water and Rivers Commission</p> <p>(ii) Water and Rivers Commission and Water Corporation</p>	<p>(i) 2000/2001</p> <p>(ii) on completion of surveillance guidelines.</p>
8.	<p>Initiate investigation into contamination risks from large catchments to aquifers recharged from river flows.</p>	<p>Water and Rivers Commission</p>	<p>To be arranged</p>
9.	<p>Fencing of re-equipped bores and regular maintenance of existing fenced bore compounds.</p>	<p>Water Corporation</p>	<p>Ongoing</p>
10.	<p>Maintenance of bores to prevent leaking causing semi permanent pools</p>	<p>Water Corporation</p>	<p>Ongoing</p>
11.	<p>Review of this plan and recommendations.</p> <p>(i) review implementation strategy annually.</p> <p>(ii) full review after 5 years</p>	<p>Water and Rivers Commission, Water Quality Protection Branch</p>	<p>(i) Initial review-2001/2002</p> <p>(ii) Full review-2006/07</p>

References

Davidson, W.A. '*Yule River Groundwater Reassessment*', Geological Survey of Western Australia, Record No. 1976/10, 17th June 1976.

National Medical & Health Research Council (1996) *Australian Drinking Water Guidelines*. National Medical & Health Research Council and Agriculture and Resource Management Council of Australia and New Zealand.

Skidmore, D. J. P (1996) *Groundwater Resources of Major Catchments in the Pilbara Region, Western*

Australia. Water and Rivers Commission Hydrogeology Report No. 35.

Water Corporation, (1996a) *Groundwater Scheme Review – Yule River*. Infrastructure Planning Branch, Planning and Development Division, January 1996.

Water Corporation (1996b) *Yule River Borefield, Hydrogeology and Investigation Plan*. Infrastructure Planning Branch, Planning and Development Division, November 1996.



Glossary

Abstraction	Pumping groundwater from an aquifer.
Allocation	The quantity of groundwater permitted to be abstracted by a well licence, usually specified in kilolitres/year (kL/a).
Alluvium (alluvial)	Detrital material which is transported by streams and rivers and deposited.
Aquifer	A geological formation or group of formations able to receive, store and transmit significant quantities of water.
Bore	A narrow, lined hole drilled to monitor or withdraw groundwater.
Catchment	The area of land which intercepts rainfall and contributes the collected water to surface water (streams, rivers, wetlands) or groundwater.
Groundwater	Water which occupies the pores and crevices of rock or soil.
Hydrogeology	The study of groundwater, especially relating to the distribution of aquifers, groundwater flow and groundwater quality.
Pollution	Water pollution occurs when waste products or other substances e.g. effluent, litter, refuse, sewage or contaminated runoff, change the physical, chemical, biological or thermal properties of the water, adversely affecting water quality, living species and beneficial uses.
Recharge	Water infiltrating to replenish an aquifer.
Recharge Area	An area through which water from a groundwater catchment percolates to replenish (recharge) an aquifer. An unconfined aquifer is recharged by rainfall throughout its distribution. Confined aquifers are recharged in specific areas where water leaks from overlying aquifers, or where the aquifer rises to meet the surface.
Unconfined Aquifer	An aquifer containing water, the upper surface of which is lower than the top of the aquifer. The upper surface of the groundwater within the aquifer is called the watertable.
Wastewater	Water that has been used for some purpose and would normally be treated and discarded. Wastewater usually contains significant quantities of pollutant.
Water Quality	The physical, chemical and biological measures of water.
Watertable	The upper saturated level of the unconfined groundwater.
Wellfield	A group of bores to monitor or withdraw groundwater.



Appendices

Appendix 1: Land use compatibility in Public Drinking Water Source Areas



LAND USE COMPATIBILITY IN PUBLIC DRINKING WATER SOURCE AREAS

Purpose

To provide information on land use and activities that may impact on the quality of the State's water resources.

These notes provide a basis for developing formal guidelines in consultation with key stakeholders.

Scope

These notes apply to proposed and existing land use within Public Drinking Water Source Areas (PDWSAs).

PDWSAs include Underground Water Pollution Control Areas, Water Reserves and public water supply catchment areas declared under the *Metropolitan Water Supply, Sewerage and Drainage Act 1909*, and the *Country Areas Water Supply Act 1947*.

Preamble

The following notes reflect the Commission's current position. They are recommendations only, and may be varied at the discretion of the Commission.

Overview of Protection Framework

The Water and Rivers Commission is responsible for managing and protecting Western Australia's water resources. The Commission has policies for the protection of public drinking water source areas that include three levels of priority classification of lands within PDWSAs.

Priority 1 (P1) source protection areas are defined to ensure that there is **no degradation** of the water source. P1 areas are declared over land where the provision of the highest quality public drinking water is the prime beneficial land use. P1 areas would typically include land under Crown ownership. P1 areas are managed in accordance with the principle of **risk avoidance** and so land development is generally not permitted.

Priority 2 (P2) source protection areas are defined to ensure that there is **no increased risk of pollution** to the water source. P2 areas are declared over land where low intensity development (such as rural) already exists. Protection of public water supply sources is a high priority in these areas. P2 areas are managed in accordance with the principle of **risk minimisation** and so some development is allowed under specific conditions.



Priority 3 (P3) source protection areas are defined to **manage the risk of pollution** to the water source. P3 areas are declared over land where water supply sources need to co-exist with other land uses such as residential, commercial and light industrial developments.

Protection of P3 areas is achieved through **management guidelines** for land use activities. If the water source does become contaminated, then water may need to be treated or an alternative water source found.

In addition to priority classifications, **well-head protection zones** and **reservoir protection zones** are defined to protect the water source from contamination in the immediate vicinity of production wells and reservoirs. Well-head protection zones are usually circular, with a radius of 500 metres in P1 areas and 300 metres in P2 and P3 areas. Reservoir protection zones usually consist of a 2 kilometre buffer area around the top water level of a reservoir and include the reservoir itself. These zones do not extend outside water reserves. Special restrictions apply within these zones.

Tables showing Land Use Compatibility with the Commission's PDWSA protection strategy

These tables should be used as a guideline only. More detailed information on the Commission's requirements in the form of activity guidelines or notes is available for some land uses. These can be found on the 'Protecting Water' web page on the Commission's Internet site (www.wrc.wa.gov.au). Alternately information relating to land use and development within PDWSAs including those not listed in the tables, can be obtained from the Commission's Water Quality Protection Branch.

The Commission recognises that many activities were established before the introduction of these tables. The Commission will negotiate with the operators of such activities to develop appropriate management practices to minimise the impact on water resources.

These tables do not replace the need for assessment by the Commission. Please consult the Commission for advice on any land use proposals in Public Drinking Water Source Areas that may impact on water resources.

Definitions used in the following tables

<i>Compatible</i>	The land use is compatible with the management objectives of the priority classification.
<i>Incompatible</i>	The land use is incompatible with the management objectives of the priority classification.
<i>Conditional</i>	The land use can be compatible with the management objectives of the priority classification, with appropriate site management practices. All conditional developments / activities should be referred to the Commission for assessment on a case specific basis.
<i>Extensive</i>	Where limited additional inputs are required to support the desired land use. eg supplementary animal feed only during seasonal dry periods.
<i>Intensive</i>	Where regular additional inputs are required to support the desired land use. eg irrigation, fertilisers and non forage animal feed dominates.



More information

We welcome your comment on these notes. They will be updated from time to time as comments are received or activity standards change. The Commission is progressively developing Water Quality Protection Notes and Guidelines covering land uses described in the attached tables. Advice on available guidance documents may be obtained by contacting the Commission.

If you wish to comment on the notes or require more information, please contact the Commission's Water Quality Protection Branch at the Hyatt Centre in East Perth.

Phone: (08) 9278 0300 (business hours) or Fax:(08) 9278 0585.

E-mail: use the {feedback} section at our Internet address (<http://www.wrc.wa.gov.au>) citing the topic and version.



Tables showing Land use compatibility with PDWSA protection objectives

AGRICULTURE - ANIMALS

Land use	Priority 1	Priority 2	Priority 3
Animal saleyards and stockyards ¹⁴	Incompatible	Incompatible ⁷	Conditional ⁷
Apiaries on Crown land	Conditional	Conditional	Conditional
Aquaculture eg. crustaceans, fish, algae farms	Incompatible	Conditional	Conditional
Dairy sheds	Incompatible	Incompatible ^{11,15}	Conditional ¹⁵
Feedlots	Incompatible	Incompatible	Conditional
Livestock grazing - pastoral leases	Conditional	Compatible	Compatible
Livestock grazing - broad acre (extensive)	Incompatible	Conditional ¹¹	Compatible
Livestock grazing (intensive)	Incompatible	Incompatible	Conditional ¹¹
Piggeries	Incompatible	Incompatible	Incompatible
Poultry farming (housed)	Incompatible	Conditional	Conditional
Stables	Incompatible	Conditional	Compatible

AGRICULTURE - PLANTS

Land use	Priority 1	Priority 2	Priority 3
Broad acre cropping i.e. non-irrigated	Incompatible	Conditional ¹	Compatible
Floriculture (extensive)	Incompatible	Conditional	Compatible
Floriculture (intensive)	Incompatible	Incompatible	Conditional
Horticulture- hydroponics	Incompatible	Conditional	Conditional
Horticulture - market gardens	Incompatible	Incompatible	Conditional
Orchards	Incompatible	Conditional	Compatible
Nurseries (potted plants)	Incompatible	Conditional	Compatible
Silviculture (tree farming)	Conditional	Conditional	Compatible
Turf farms	Incompatible	Incompatible	Conditional
Viticulture (wine & table grapes)	Incompatible	Conditional	Compatible

DEVELOPMENT - COMMERCIAL

Land use	Priority 1	Priority 2	Priority 3
Aircraft servicing	Incompatible	Incompatible	Conditional ⁶
Airports or landing grounds	Incompatible	Incompatible	Conditional ⁶
Amusement centres	Incompatible	Incompatible	Compatible ⁶
Automotive businesses	Incompatible	Incompatible	Conditional ⁶
Boat servicing	Incompatible	Incompatible	Conditional ⁶
Catteries	Incompatible	Compatible	Compatible
Caravan and trailer hire	Incompatible	Incompatible	Conditional ⁶
Consulting rooms	Incompatible	Incompatible ⁷	Compatible ⁶
Concrete batching and cement products	Incompatible	Incompatible	Conditional
Cottage Industries	Conditional	Conditional	Compatible
Dog kennels	Incompatible	Conditional	Conditional
Drive in / take-away food shops	Incompatible	Incompatible	Compatible ⁶
Drive -in theatres	Incompatible	Incompatible	Compatible ⁶
Dry cleaning premises	Incompatible	Incompatible	Conditional ⁶



Farm supply centres	Incompatible	Incompatible ⁷	Conditional
Fuel depots	Incompatible	Incompatible	Conditional
Garden centres	Incompatible	Incompatible	Compatible
Laboratories (analytical , photographic)	Incompatible	Incompatible	Conditional ⁶
Markets	Incompatible	Incompatible	Compatible ⁶
Mechanical servicing	Incompatible	Incompatible	Conditional ⁶
Metal production / finishing	Incompatible	Incompatible	Incompatible
Milk transfer depots	Incompatible	Incompatible	Conditional
Pesticide operator depots	Incompatible	Incompatible	Incompatible
Restaurants and taverns	Incompatible	Incompatible	Compatible ⁶

Land use	Priority 1	Priority 2	Priority 3
Service stations	Incompatible	Incompatible	Conditional ⁶
Shops and shopping centres	Incompatible	Incompatible ⁷	Compatible ⁶
Transport depots	Incompatible	Incompatible	Conditional
Vehicle parking (commercial)	Incompatible	Incompatible	Compatible
Vehicle wrecking and machinery	Incompatible	Incompatible	Conditional
Veterinary clinics / hospitals	Incompatible	Incompatible ⁷	Conditional ⁶

DEVELOPMENT - INDUSTRIAL

Land use	Priority 1	Priority 2	Priority 3
Heavy Industry	Incompatible	Incompatible	Incompatible
Light or general Industry	Incompatible	Incompatible	Conditional ⁶
Power Stations	Incompatible	Incompatible	Incompatible

DEVELOPMENT - URBAN

Land use	Priority 1	Priority 2	Priority 3
Aged and dependent persons group dwellings	Incompatible	Incompatible	Compatible ⁶
Cemeteries	Incompatible	Incompatible	Conditional
Civic buildings	Incompatible	Conditional ⁷	Compatible ⁶
Clubs -sporting or recreation	Incompatible	Conditional	Compatible ⁶
Community halls	Incompatible	Conditional ⁷	Compatible
Family day care centres	Incompatible	Incompatible ⁷	Compatible ⁶
Funeral parlours	Incompatible	Incompatible	Compatible ⁶
Health centres	Incompatible	Incompatible	Compatible ⁶
Hospitals	Incompatible	Incompatible	Conditional ⁶
Medical centres	Incompatible	Incompatible	Compatible ⁶
Toilet blocks and change rooms	Incompatible ⁷	Conditional	Compatible

EDUCATION / RESEARCH

Land use	Priority 1	Priority 2	Priority 3
Community education centres	Conditional ⁷	Conditional ⁷	Compatible ⁶
Primary / Secondary Schools	Incompatible	Incompatible	Compatible ⁶
Scientific Research	Conditional	Conditional	Compatible
Tertiary Education Facilities	Incompatible	Incompatible	Conditional ⁶



MINING AND MINERAL PROCESSING

Land use	Priority 1	Priority 2	Priority 3
Extractive industries (sand mining, quarries)	Conditional ²	Conditional ²	Conditional ²
Mineral exploration	Conditional ⁴	Conditional ⁴	Conditional ⁴
Mining	Conditional ⁴	Conditional ⁴	Conditional ⁴
Mineral processing	Incompatible	Incompatible	Conditional ⁴
Tailings dams	Incompatible	Incompatible	Conditional ⁴

PROCESSING OF ANIMALS / ANIMAL PRODUCTS

Land use	Priority 1	Priority 2	Priority 3
Animal product rendering works	Incompatible	Incompatible	Incompatible
Abattoirs	Incompatible	Incompatible	Incompatible
Dairy product factories	Incompatible	Incompatible	Conditional ⁶
Food Processing	Incompatible	Incompatible	Conditional ⁶
Tanneries	Incompatible	Incompatible	Incompatible
Wool-scourers	Incompatible	Incompatible	Incompatible

PROCESSING OF PLANTS / PLANT PRODUCTS

Land use	Priority 1	Priority 2	Priority 3
Breweries	Incompatible	Incompatible	Conditional ⁶
Composting / soil blending (commercial)	Incompatible	Incompatible	Conditional
Vegetable / food processing	Incompatible	Incompatible	Conditional ⁶
Wineries	Incompatible	Incompatible	Conditional

SUBDIVISION

Land use	Priority 1	Priority 2	Priority 3
Rural subdivision to a minimum lot size of 4 ha	Incompatible	Compatible	Compatible
Rural subdivision to a lot size less than 4 ha	Incompatible	Incompatible	Incompatible
Special rural subdivision to a minimum lot size of 2 ha	Incompatible	Conditional ^{8,9}	Conditional ⁸
Special rural subdivision to a lot size between 1 and 2 ha	Incompatible	Incompatible	Conditional ^{8,9}
Special rural subdivision to a lot size less than 1 ha	Incompatible	Incompatible	Incompatible
Urban subdivision	Incompatible	Incompatible	Compatible ⁶
Industrial subdivision	Incompatible	Incompatible	Conditional ⁶

Note: Subdivision of lots to any size within Priority 1 areas is incompatible

SPORT AND RECREATION

Land use	Priority 1	Priority 2	Priority 3
Equestrian centres	Incompatible	Incompatible	Compatible
Golf courses	Incompatible	Incompatible	Conditional ¹
Motor sports ie permanent racing facilities	Incompatible	Incompatible	Conditional



Public swimming pools	Incompatible	Incompatible	Conditional
Recreational parks -irrigated	Incompatible	Incompatible	Conditional ¹
Rifle ranges	Incompatible	Conditional	Compatible

STORAGE/ PROCESSING OF TOXIC AND HAZARDOUS SUBSTANCES (THS)

Land use	Priority 1	Priority 2	Priority 3
Above ground storage of THS	Conditional	Conditional	Conditional
Underground storage tanks for THS	Incompatible	Incompatible	Conditional

TOURISM ACCOMMODATION.

Land use	Priority 1	Priority 2	Priority 3
Bed and breakfast accommodation	Incompatible	Conditional ¹⁶	Compatible
Caravan parks	Incompatible	Incompatible	Conditional ⁶
Farm stay accommodation	Incompatible	Conditional ¹⁶	Compatible
Motels, hotels, lodging houses, hostels	Incompatible	Incompatible	Compatible ⁶

WASTE TREATMENT AND MANAGEMENT

Land use	Priority 1	Priority 2	Priority 3
Injection of liquid wastes into ground water	Incompatible	Incompatible	Incompatible
Landfills -Class I, II or III	Incompatible	Incompatible	Conditional
Landfills -Class IV and V	Incompatible	Incompatible	Incompatible
Recycling depots	Incompatible	Incompatible	Conditional
Refuse transfer stations	Incompatible	Incompatible	Conditional
Sewers (gravity)	Incompatible	Incompatible	Compatible
Sewers (pressure mains)	Incompatible	Conditional	Compatible
Sewage pump stations	Incompatible	Conditional	Conditional
Used tyre storage / disposal facilities	Incompatible	Incompatible	Incompatible
Wastewater treatment plants	Incompatible	Incompatible	Conditional
Wastewater application to land	Incompatible	Incompatible ¹⁷	Conditional

OTHER DEVELOPMENTS

Land use	Priority 1	Priority 2	Priority 3
Caretaker's housing	Incompatible ⁷	Conditional	Compatible
Drinking water treatment plants	Conditional	Conditional	Conditional
Communications receivers / transmitters	Conditional	Conditional	Conditional
Construction projects (not shown elsewhere)	Conditional	Conditional	Conditional
Forestry	Conditional ¹	Compatible	Compatible
Major transport routes	Incompatible	Conditional ¹⁰	Compatible
National and Regional Parks ¹³	Compatible	Compatible	Compatible
Nature reserves	Compatible	Compatible	Compatible

Table reference notes:



-
1. Conditions may limit fertiliser and pesticide application.
 2. Conditions cover the storage of fuels and chemicals, the depth of mining in relation to the water table with strict guidelines for rehabilitation.
 3. Conditions cover the storage and use of fuel and other chemicals.
 4. Conditions placed via the mining lease and / or environmental approval.
 5. Special rural development must have appropriate provisions under the Town Planning Scheme, to prevent introduction of land uses and practices that pose an unacceptable risk to water resources.
 6. Must be connected to deep sewerage, except where exemptions apply under the current Government Sewerage Policy.
 7. Only permitted if this use is incidental to the overall land use in the area and consistent with planning strategies.
 8. Lots should only be created where land capability allows effective on-site soakage disposal of treated wastewater. Conditions apply to siting of wastewater disposal systems in areas with poor land capability and / or a shallow depth to groundwater, animals are held or fertiliser is applied. Alternative wastewater treatment systems, where approved by the Health Department, may be accepted with maintenance requirements.
 9. An average rather than minimum lot size may be acceptable if the proponent can demonstrate that the water quality objectives of the source protection area are met, and caveats are placed on titles of larger blocks stating that further subdivision cannot occur.
 10. Conditions cover road design, construction and the types of goods that may be carried.
 11. May be permitted if animal stocking levels (number of animals per hectare) are consistent with source protection objectives.
 12. May be permitted if the type, volume and storage mechanisms for chemicals are compatible with water quality protection objectives.
 13. Visitor and management infrastructure and facilities must be appropriately sited and maintained.
 14. This does not include on-farm / pastoral lease stock-yards used for animal husbandry
 15. Waste management practices must be compatible with source protection objectives.
 16. Conditions apply on density of accommodation in Priority 2 areas
 17. May be permitted if the quantity and quality are compatible with water quality protection objectives.



Appendix 2: Above ground chemical storage tanks
in Public Drinking Water Source
Areas



ABOVE GROUND CHEMICAL STORAGE TANKS IN PUBLIC DRINKING WATER SOURCE AREAS

Purpose

To provide information for facilities that may impact on the quality of the State's water resources.

These notes provide a basis for developing formal best management practice guidelines in consultation with key stakeholders.

Scope

These notes apply in Public Drinking Water Source Areas where chemicals that are potentially polluting, toxic or hazardous (including fuel) are stored in above ground tanks.

Chemicals covered by these notes include:

- Substances listed in Section 4 of the *Australian Water Quality Guidelines for Fresh and Marine Waters* published by the Australian and New Zealand Environment and Conservation Council (ANZECC), 1992.
- Substances described in the current Schedules of the *Poisons Act 1964*.
- Concentrates and substances listed in Schedule Classes 3 to 9 of the *Explosive and Dangerous Goods Act, Classification Order of 1988*.

Chemicals used for hygiene or similar non-commercial purposes in quantities less than 25 litres are excluded.

These notes apply to facilities that will be used for 12 months or more. For temporary installations (used for less than 12 months) refer to Water Quality Protection Note – *Temporary Above Ground Fuel Storage in Public Drinking Water Source Areas*.

Public Drinking Water Source Areas (PDWSAs) describe areas declared under the *Metropolitan Water Supply, Sewerage and Drainage Act 1909* and the *Country Areas Water Supply Act 1947* for the management and protection of sources of water used for public drinking water supply. They include declared Underground Water Pollution Control Areas (UWPCAs), Water Reserves and Catchment Areas.

Three priority classification areas have been defined in PDWSAs. They are **P1, P2 and P3**. Priority is determined by land tenure, land use and water flow paths. Different management strategies apply in each priority area. For further details refer to Water Quality Protection Note – *Land Use Compatibility in Public Drinking Water Source Areas*.

Above ground chemical storage tanks also require approval from the Department of Minerals and Energy (DME).

General recommendations

The following notes reflect the Commission's current position. They are recommendations only and may be varied at the discretion of the Commission.



Proposals for above ground chemical storage systems in PDWSAs need to be assessed by the Water and Rivers Commission prior to DME approval. The proposal should include:

- A site plan showing the location of the facility.
- Construction details of tanks and their associated containment compounds.
- An inspection and maintenance schedule for the facility to ensure effective containment of chemicals.

If the proposal is located in a UWPCA, a permit with approval conditions from the Commission is also required.

Chemicals including petroleum products should not be stored within 2 kilometres of the top water level of public water supply reservoirs.

In P1 and P2 public drinking water source areas, elevated tanks are not permitted inside wellhead protection zones.

In P1 and P2 public drinking water source areas, the total tank storage volume shall not exceed 5000 litres unless written approval is granted based on an environmental risk assessment.

Containment Compound Design

Storage tanks and associated containment compounds should comply with the current Australian Standard 1940, and the *Explosive and Dangerous Goods Act 1961* and its regulations.

Storage tanks should be located within containment compounds that effectively capture and contain chemical spills. These compounds should capture any leak or jet of liquid from any perforation of the tank or associated equipment. The Commission's minimum design criteria are appended to these notes as **Plan No. 1**.

Compounds should be constructed of waterproof reinforced concrete or approved equivalent, which is not adversely affected by contact with chemicals captured within them.

The minimum compound volume should be 110% of the capacity of the largest tank system, plus 25% of the **total capacity of all** other separate tanks and containers within the compound.

In P1 and P2 areas, underground pipe-work carrying product from the tank to facilities outside the containment compound is **not** acceptable. In P1 and P2 areas, above ground pipe-work should be double contained. In P3 areas, underground pipe-work should have double containment. Pipe-work within the bund does not require double containment.

Containment compounds should have sufficient capacity to retain spilt chemicals and not be overtopped during extreme rainfall events. Additional capacity for rainfall captured within the compound should be calculated using a 1 in 100 year return frequency storm event over 24 hours. Stormwater assessment methods should be used as described in the current edition of *Australian Rainfall and Runoff* produced by the Institution of Engineers, Australia.

Tank equipment such as dispensing hoses, valves, meters, pumps, and gauges should be located within the containment compound.

Security should be provided to guard against vandalism when the site is unattended. This should include:

- Fencing of the tank compound or adequate security controls at the site.
- Locks on unattended dispensing hoses.

The base of the containment compound should grade towards a liquid retention sump to facilitate recovery of spilt liquids. The compound if exposed to storm-water intrusion, should be emptied by pumping, **not** through a valved gravity outlet, which could inadvertently be left open. Enclosed containment compounds should have adequate inspection and venting ports.

Incompatible or reactive chemicals should be stored in separate banded compounds.



All chemicals stored within the bunded compounds should be clearly labelled detailing the nature and quantity of chemicals within individual containers. Sight gauges indicating the current volume are recommended for tanks larger than 250 litre capacity.

Chemical transfer areas

All chemical transfer activities (in and out of tanks) should occur on an impervious sealed area; kerbed, graded or bunded to prevent liquid runoff to the environment.

Chemical transfer areas should drain away from the perimeter bund to a containment pit. The pit should be capable of holding stormwater from at least a 48 hour, 2 year return frequency storm event, in addition to containing potential chemical spills. Designs should provide for the safe and efficient movement of vehicles.

Operation of containment compounds

Chemical spills should be cleaned up on discovery. The spilt liquid and clean-up material should be removed, treated and disposed of outside any PDWSA in accordance with requirements of the Department of Environmental Protection's (DEP) Waste Management Division.

The compound should be maintained to prevent accumulation of stormwater and litter. Only stormwater assessed as uncontaminated by a qualified and experienced person may be released to the environment.

In **P1 and P2** areas, one of the following measures should be used to prevent accumulation of stormwater:

- An enclosure, or roofed structure that extends at least 1 metre past the edge of the compound. Side walls or vertical roof turn-downs should be used (if appropriate) to prevent intrusion of wind-driven rainfall.
- A reliable assessment and management procedure for disposal of stormwater. The procedure should be documented and submitted to the Commission for approval.

In **P3** areas, adoption of one of the following measures is recommended:

- Collect and dispose of stormwater to outside any PDWSA in accordance with the requirements of the DEP -Waste Management Division.
- Treat stormwater on-site in a separation unit to effectively remove contaminating substances. The method of treatment will depend on whether effluent is discharged to sewer or disposed of on-site in soaks. Any liquid released to the environment should conform to the criteria for Raw Water for Drinking Water Supply given in *Australian Water Quality Guidelines for Fresh and Marine Waters* – ANZECC (1992).

More information

We welcome your comment on these notes. They will be updated from time to time as comments are received or industry standards change.

If you wish to comment on the notes or require more information, please contact the Commission's Water Quality Protection Branch at the Hyatt Centre in East Perth.

Phone: (08) 9278 0300 (business hours) or Fax: (08) 9278 0585



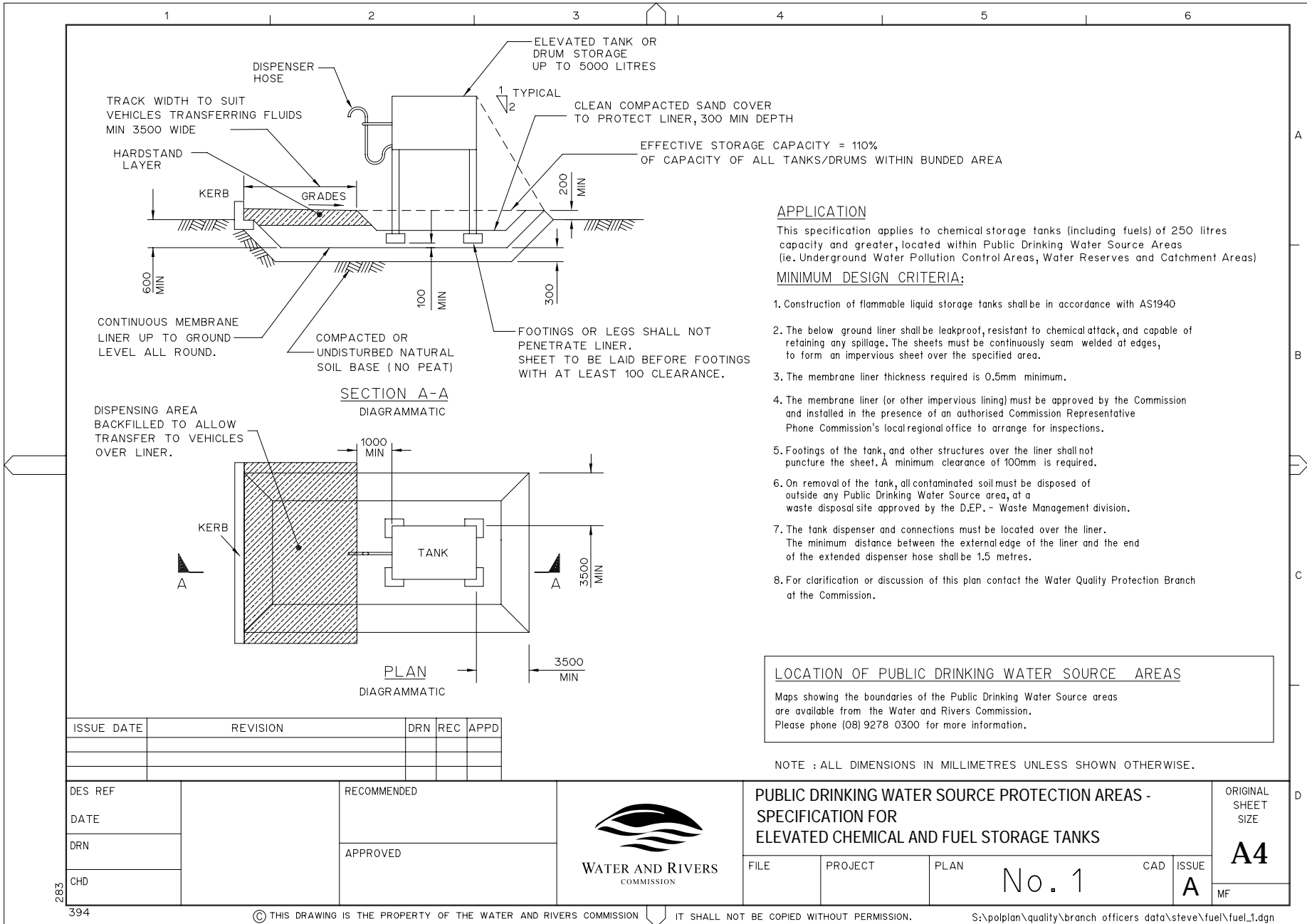

APPLICATION

This specification applies to chemical storage tanks (including fuels) of 250 litres capacity and greater, located within Public Drinking Water Source Areas (ie. Underground Water Pollution Control Areas, Water Reserves and Catchment Areas)

MINIMUM DESIGN CRITERIA:

1. Construction of flammable liquid storage tanks shall be in accordance with AS1940
2. The below ground liner shall be leakproof, resistant to chemical attack, and capable of retaining any spillage. The sheets must be continuously seam welded at edges, to form an impervious sheet over the specified area.
3. The membrane liner thickness required is 0.5mm minimum.
4. The membrane liner (or other impervious lining) must be approved by the Commission and installed in the presence of an authorised Commission Representative. Please contact the Commission's local regional office to arrange for inspections.
5. Footings of the tank, and other structures over the liner shall not puncture the sheet. A minimum clearance of 100mm is required.
6. On removal of the tank, all contaminated soil must be disposed of outside any Public Drinking Water Source area, at a waste disposal site approved by the D.E.P. - Waste Management division.
7. The tank dispenser and connections must be located over the liner. The minimum distance between the external edge of the liner and the end of the extended dispenser hose shall be 1.5 metres.
8. For clarification or discussion of this plan contact the Water Quality Protection Branch at the Commission.

LOCATION OF PUBLIC DRINKING WATER SOURCE AREAS
 Maps showing the boundaries of the Public Drinking Water Source areas are available from the Water and Rivers Commission. Please phone (08) 9278 0300 for more information.

NOTE : ALL DIMENSIONS IN MILLIMETRES UNLESS SHOWN OTHERWISE.

ISSUE DATE	REVISION	DRN	REC	APPD

DES REF	RECOMMENDED
DATE	
DRN	
CHD	APPROVED



PUBLIC DRINKING WATER SOURCE PROTECTION AREAS - SPECIFICATION FOR ELEVATED CHEMICAL AND FUEL STORAGE TANKS

FILE	PROJECT	PLAN	CAD	ISSUE
		No. 1		A

ORIGINAL SHEET SIZE
A4
 MF

283

394

Appendix 3: Plates of land use within the Yule River Water Reserve





Plate 1: Cattle gathering around the bore compound.





Publication feedback form

The Water and Rivers Commission welcomes feedback to help us to improve the quality and effectiveness of our publications. Your assistance in completing this form would be greatly appreciated.

Please consider each question carefully and rate them on a 1 to 5 scale, where 1 is poor and 5 is excellent (*please circle the appropriate number*).

Publication title

How did you rate the quality of information?

1 2 3 4 5

How did you rate the design and presentation of this publication?

1 2 3 4 5

How can it be improved?

.....
.....
.....

How effective did you find the tables and figures in communicating the data?

1 2 3 4 5

How can they be improved?

.....
.....
.....

How did you rate this publication overall?

1 2 3 4 5

If you would like to see this publication in other formats, please specify. (Eg. CD)

.....

Please cut along the dotted line on the left and return your completed response to:

**Publications Coordinator
Water and Rivers Commission
Level 2, Hyatt Centre
3 Plain Street
East Perth WA 6004
Fax: (08) 9278 0704**